

	Seite
Service rund um die Schraube	3
Lieferprogramm	4
So nutzen Sie diesen Katalog	62
1 Schrauben	63
2 Muttern	263
3 Scheiben und Sicherungselemente	323
4 Keile und Stifte	395
5 Splinte und Federstecker	441
6 Nieten	453
7 Normalien	459
8 Gewindeeinsätze	487
9 Muffen	499
Technischer Anhang	513
Stichwortverzeichnis	596
Impressum	

1



2



3



4



5



6



7



8



9





1



2



3



4



5

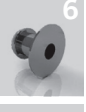

6



7



8



9

Breites Sortiment

Unser Artikelportfolio umfasst über 100.000 Artikel aus den Bereichen Verbindungselemente, Befestigungstechnik sowie kundenspezifische Sonderartikel. Hiervon bevorraten wir für Sie 40.000 Artikel in allen gängigen Abmessungen, Werkstoffen und Beschichtungen. Daneben führen wir über 60.000 kundenspezifische Artikel und zeichnungsgefertigte Sonderteile in allen Werkstoffen, Sonderwerkstoffen und außergewöhnlichen Beschichtungsverfahren.

Moderne Logistik

Unsere Mitarbeiterinnen und Mitarbeiter sorgen mit modernsten, voll-automatisierten Logistiklösungen für die sichere Versorgung mit C-Teilen unserer Kunden in Deutschland und der ganzen Welt. Schnell, pünktlich und zuverlässig – das ist unsere Maxime. Wenn Sie bis 17 Uhr bestellen, liefern wir Ihre Artikel bundesweit am nächsten Werktag mit unserem eigenen Fuhrpark oder mit einem unserer langjährigen Vertragspartner.

Hohe Qualität

Die Anforderungen an unsere Produkt- und Servicequalität sind sehr hoch. Neben der Überprüfung unserer Produkte lassen wir jährlich auch unsere eigene Arbeit überprüfen und erfüllen so seit vielen Jahren die Auflagen des Qualitätsmanagementsystems DIN EN ISO 9001. Seit August 2017 haben wir zusätzlich ein Umweltmanagementsystem nach DIN EN ISO 14001 sowie ein Energiemanagementsystem nach DIN EN ISO 50001 integriert. Diesen hohen Aufwand in den Bereichen Qualität, Umwelt und Energie nehmen wir auf uns um unseren eigenen Anforderungen gerecht zu werden und um Ihnen eine gleichbleibend hohe Qualität anbieten zu können.

C-Teile-Management

Mit attraktiven C-Teile-Management Lösungen reduzieren wir Ihren Beschaffungsaufwand. Sie nennen uns Ihren Bedarf, wir erledigen für Sie die Materialbeschaffung, Lagerung und Lieferung. So profitieren Sie von einem absolut reibungslosen Service und sparen Zeit, Nerven und Beschaffungskosten. Auf Wunsch können wir jederzeit Komplementärartikel in Ihr bestehendes Versorgungssystem integrieren. Profitieren Sie von unserer Erfahrung, die für Sie minimaler Aufwand und höchste Versorgungssicherheit bedeutet.

Kanban-Systeme

Unsere intelligenten Kanban-Systeme sorgen bei unseren Kunden für höchste Materialversorgungssicherheit. Unterstützt durch moderne Datenübertragungswege stellen wir so Ihre reibungslose Versorgung und damit Ihre Prozesse sicher. Auch kundenindividuelle Anforderungen oder Aufgabenstellungen stellen dabei kein Problem dar - fordern Sie uns, wir werden Sie nicht enttäuschen!

Kompetente Berater

Wir sind der kompetente Ansprechpartner für alle Fragen rund um die Welt der Verbindungselemente und Befestigungstechnik. Unsere erfahrenen Fachberater helfen Ihnen bei allen Anforderungen bis ins Detail und sind dank regelmäßiger Produktschulungsmaßnahmen dabei stets auf dem neuesten Stand der Technik. Sprechen Sie mit uns und profitieren Sie von unserem technischen Know-how - an unseren Standorten oder direkt mit unseren Außendienstmitarbeitern bei Ihnen vor Ort!

E-Business

Ob originärer Online-Shop, barcode- und scannerbasierende Bestellvorgänge (Self-Scan), Austausch von Artikelstammdaten via Katalogaustauschformat (BMEcat), direkte Anbindung an Ihr ERP-System via Electronic Data Interchange (EDI) oder Open Catalog Interface (OCI), unsere umfangreichen E-Business Lösungen bringen neue Flexibilität in Ihren Bestellprozess.

Gesicherte Zukunft

Durch permanente Innovationen ist die Weiterentwicklung unseres Produkt- und Dienstleistungsangebots garantiert. Das bedeutet für Sie: Wir sind auch in Zukunft der kompetente Partner für alle Produkte und Dienstleistungen, die mit der Welt der Verbindungselemente und Befestigungstechnik in Verbindung stehen. Nehmen Sie uns beim Wort!

1



2



3



4



5



6



7



8



9









Abbildung	Bezeichnung	Norm	Seite
	Kegelstifte Taper pins Goupilles coniques	DIN 1	396 - 397
	Zylinderstifte ungehärtet Parallel pins, unhardened Goupilles cylindriques non trempées	DIN 7	398 - 399
	Feste Ballengriffe Fixed machine handles Poignées bombées, fixes	DIN 39	460
	Zylinderkopfschrauben mit Schlitz Slotted cheese head screws Vis à tête cylindrique fendue	DIN 84	64 - 65
	Flachkopfschrauben mit Schlitz Slotted pan head screws Vis à tête cylindrique fendue, tête large	DIN 85	66 - 67
	Scheiben mit Lappen Tab washer Frein d'écrou à aileron	DIN 93	324
	Splinte Split pins Goupilles fendues	DIN 94	442 - 443





Abbildung	Bezeichnung	Norm	Seite
	<p>Holzschrauben mit Linsensenkkopf und Schlitz Slotted raised countersunk head wood screws Vis à bois à tête fraisée bombée, fendue</p>	DIN 95	68
	<p>Holzschrauben mit Halbrundkopf und Schlitz Slotted round head wood screws Vis à bois à tête ronde fendue</p>	DIN 96	69
	<p>Holzschrauben mit Senkkopf und Schlitz Slotted countersunk head wood screws Vis à bois à tête fraisée fendue</p>	DIN 97	70
	<p>Drehbarer Ballenriff Revolving machine handles Poignées bombées, tournante</p>	DIN 98	-
	<p>Kegelgriff Clamping levers Manettes de blocage filetées</p>	DIN 99	461
	<p>Scheiben Plain washers, chamfered out without chamfer standard Rondelles plates, avec ou sans chanfrein standard</p>	DIN 125	325
	<p>Scheiben Plain washers Rondelles plates</p>	DIN 126	326



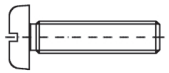
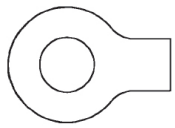
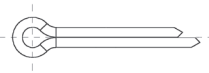

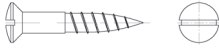

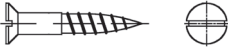

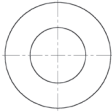
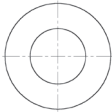
Abbildung	Bezeichnung	Norm	Seite
	Federringe Form A / Form B Spring lock washers type A and B Rondelles élastiques „grower“ forme A et B	DIN 127	327
	Federringe Form A: gewölbt Spring lock washers type A Rondelles élastiques cintrées forme A	DIN 128	328
	Scheiben Medium washers Rondelles plates	DIN 134	329
	Federscheiben Form A / Form B Wave Spring washers type A / type B Rondelles élastiques ondulées forme A / forme B	DIN 137	330 - 331
	Hammerschrauben mit Vierkant T-head bolts with square neck Vis à tête marteau à collet carré	DIN 186	-
	Hammerschrauben mit Nase T-head bolts with double nib Vis à tête marteau à collet carré à ergots	DIN 188	-
	Kegelstifte ungehärtet mit Gewindezapfen Taper pins with external thread, unhardened Goupilles de position coniques à longueur filetée, non trempées	DIN 258	-





Abbildung	Bezeichnung	Norm	Seite
	<p>Hammerschrauben T-head bolts Vis à tête marteau à collet à angle abattus</p>	DIN 261	-
	<p>Flügelmuttern Deutsche Form Wing nuts type D Ecoures à oreilles forme allemande forme D</p>	DIN 315	264
	<p>Flügelmuttern Amerikanische Form Wing nuts type A Ecoures à oreilles forme américaine forme A</p>	DIN 315 (A)	265
	<p>Flügelschrauben Wing screws Vis à oreilles</p>	DIN 316	71
	<p>Kugelknöpfe Ball knobs Poignées sphériques avec insert fileté</p>	DIN 319	462 - 463
	<p>Kreuzlochschrauben Slotted capstan screws Vis de plombage avec perçage en croix</p>	DIN 404	72
	<p>Gewindestifte mit Schlitz und Zapfen Slotted set screws with full dog point Vis sans tête, fendues, à téton long</p>	DIN 417	73



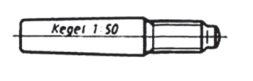

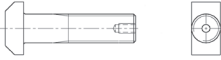
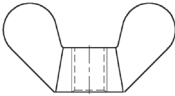
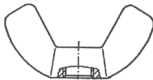

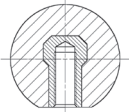
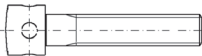



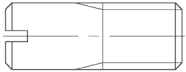

Abbildung	Bezeichnung	Norm	Seite
 	<p>Schaftschrauben mit Schlitz und Kegelkuppe Slotted headless screws with chamfered end Vis sans tête, partiellement filetéés, fendue et bout chanfreiné</p>	DIN 427	74
 	<p>Rohrmuttern Pipe nuts Ecrous pour tube</p>	DIN 431	266
 	<p>Scheiben mit Außennase Washers with external tap Freins décrous à ergot extérieur</p>	DIN 432	332
 	<p>Scheiben kleiner Außendurchmesser Plain washers (small) Rondelles plates étroites</p>	DIN 433	333
 	<p>Scheiben vierkant, keilförmig für U-Träger Square taper washers for U-sections Cales obliques pour profils en U</p>	DIN 434	334
 	<p>Scheiben vierkant, keilförmig für I-Träger Square taper washers for I-sections Cales obliques pour profils en I</p>	DIN 435	335
 	<p>Scheiben vierkant für Holzkonstruktionen Square washers for use in timber constructions Rondelles carrées pour constructions en bois</p>	DIN 436	336

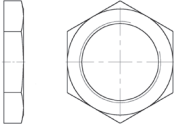
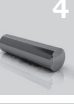
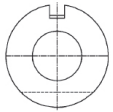

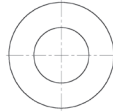

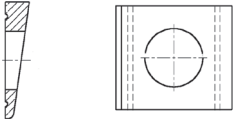
Abbildung	Bezeichnung	Norm	Seite
	Gewindestifte mit Schlitz und Ring-schneide Slotted set screws with cup point Vis sans tête fendues, à bout cuvette	DIN 438	75
	Sechskantmuttern niedrige Form Hexagon thin nuts Ecrous hexagonaux, forme basse	DIN 439	267
	Scheiben vorwiegend für Holzkonstruktionen Washers, especially for timber constructions Rondelles pour constructions bois, trou rond ou carré	DIN 440	337
	Verschlussdeckel zum Eindrücken Sealing push-in caps Couvercle de fermeture, conique	DIN 443	-
	Augenschrauben Eye bolts Vis à oeil	DIN 444	76 - 77
	Sicherungsbleche mit Innennase für Nutmuttern nach DIN 1804 Internal tab washers for hook spanner according to DIN 1804 Rondelles à ergot intérieur pour écrous selon DIN 1804	DIN 462	338
	Sicherungsbleche mit 2 Lappen Tab washers with long and short tab Freins décroés équerre à 2 ailerons	DIN 463	339

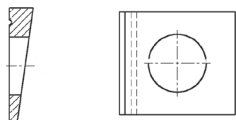

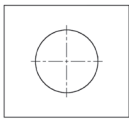



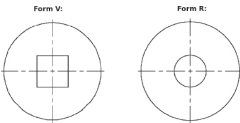
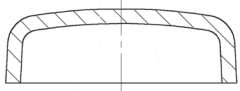

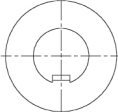
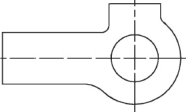
Abbildung	Bezeichnung	Norm	Seite
	Rändelschrauben hohe Form Knurled thumb screws, high type Vis à tête moletées, forme haute	DIN 464	78
	Rändelschrauben mit Schlitz Slotted knurled thumb screws, high type Vis à tête moletées, forme haute, fendue	DIN 465	-
	Rändelmuttern hohe Form Knurled nuts, high type Ecrous moletés, forme haute	DIN 466	268
	Rändelmuttern niedrige Form Knurled nuts, flat Ecrous moletés, forme basse	DIN 467	269
	Verschluss scheiben Sealing washers Rondelles de fermeture	DIN 470	340
	Sicherungsringe für Wellen Circlips (retaining rings) for shafts Circlips extérieurs pour arbre	DIN 471	341 - 342
	Sicherungsringe für Bohrungen Circlips (retaining rings) for bores Circlips intérieurs pour alésage	DIN 472	343 - 344



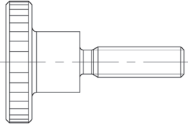
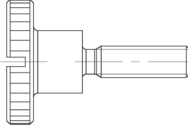

Abbildung	Bezeichnung	Norm	Seite
	<p>Vierkantschrauben mit Bund Square head bolts with collar Vis à tête carrée à embase cylindrique</p>	DIN 478	-
	<p>Vierkantschrauben mit Kernansatz Square head bolts with short dog point Vis à tête carrée à embase avec téton court</p>	DIN 479	79
	<p>Vierkantschrauben mit Bund und Ansatzkuppe Square head bolts with collar and short dog point with rounded end Vis à tête carrée à embase avec téton</p>	DIN 480	80
	<p>T-Nutensteine Nuts for T-slots Tasseaux ou écrous pour rainures en T</p>	DIN 508	270
	<p>Anschweißenden Studs for welding Tiges à souder</p>	DIN 525	81
	<p>Steinschrauben Form C Anchor bolts (stone bolt) type C Boulons de scellement forme C</p>	DIN 529	82
	<p>Schlitzmuttern Slotted round nuts Écrous cylindriques à fente</p>	DIN 546	271



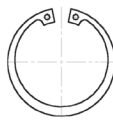

Abbildung	Bezeichnung	Norm	Seite
	Zweilochmutter Round nuts with drilled holes in one face Ecrous cylindriques à deux trous frontaux	DIN 547	272
	Kreuzlochmutter Round nut with set pin hole inside Ecrous cylindriques avec trous latéraux	DIN 548	273
	Gewindestifte mit Schlitz und Kegelkuppe Slotted set screws with flat point Vis sans tête, fendues, à bout plat	DIN 551	83
	Gewindestifte mit Schlitz und Spitze Slotted set screws with cone point Vis sans tête, fendues, à bout pointeau	DIN 553	84
	Vierkantmutter Square nuts Ecrous carrés	DIN 557	274
	Sechskantschrauben mit Zapfen und kleinem Sechskant Hexagon head set screws with small hexagon and dog point Vis à tête hexagonale réduite à téton	DIN 561	85
	Vierkantmutter niedrige Form Square thin nuts Ecrous carrés, forme basse	DIN 562	275

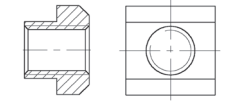

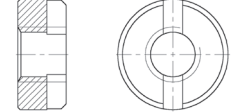
Abbildung	Bezeichnung	Norm	Seite
	Sechskantschrauben mit Ansatzspitze und kleinem Sechskant Hexagon head set screws with small hexagon and half dog flat cone point Vis à tête hexagonale réduite à bout pointu	DIN 564	86 - 87
	Sechskant-Holzschrauben Hexagon head wood screws Vis à bois à tête hexagonale - tirefonds	DIN 571	88 - 89
	Ringschrauben Lifting eye bolts Anneau de levage - male, vis à oeil	DIN 580	90 - 91
	Ringmuttern Lifting eye nuts Anneau de levage - femelle, ecrou à oeil	DIN 582	276 - 277
	Sechskantschrauben mit Schaft Hexagon head bolts Boulons de charpente à tête hexagonale	DIN 601	92 - 93
	Flachrundschrauben mit Vierkantansatz Mushroom head square neck bolts (cup square neck bolts) Boulons à tête bombée avec collet carré	DIN 603	94 - 95
	Senkschrauben mit Nase Flat countersunk nib bolts Vis à tête fraisée avec ergot	DIN 604	96 - 97







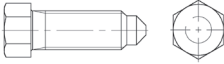
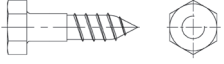
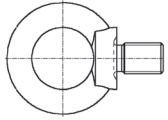
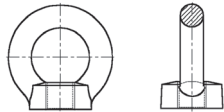

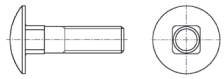
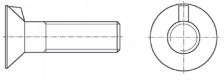
Abbildung	Bezeichnung	Norm	Seite
	Senkschrauben mit hohem Vierkant Flat countersunk square neck bolts (with long square) Vis à tête fraisée avec collet carré haut	DIN 605	98 - 99
	Halbrundschrauben mit Nase Cup head nib bolts (cup nib bolts) Vis tête ronde à ergot	DIN 607	-
	Senkschrauben mit niedrigem Vierkantansatz Flat countersunk square neck bolts (with short square) Vis à tête fraisée à collet carré - boulon de charrue	DIN 608	100 - 101
	Passschrauben mit Sechskant und langem Gewindezapfen Hexagon fits bolts with long thread Vis à épaulement tête hexagonale avec téton long	DIN 609	102 - 103
	Passschrauben mit Sechskant und kurzem Gewindezapfen Hexagon fits bolts with short thread Vis à épaulement tête hexagonale avec téton court	DIN 610	104 - 105
	Rändelschrauben niedrige Form Knurled thumb screws, low type Vis moletées, tête plate	DIN 653	106 - 107
	Halbrundnieten Round head rivets Rivets pleins à tête ronde	DIN 660	454

Abbildung	Bezeichnung	Norm	Seite
	Senknieten Countersunk head rivets Rivets pleins à tête fraisée	DIN 661	455
	Linsennieten Mushroom head rivets Rivets pleins à tête fraisée bombée	DIN 662	-
	Stellringe Form A Adjusting rings type A Bagues d'arrêt forme A	DIN 705	345
	Drahtseilklemmen Wire rope clips Serre-câbles	DIN 741	464
	T-Nutenschrauben Bolts and screws for T-slots Boulons en „T“	DIN 787	108 - 109
	Stiftschrauben Einschraubende ca. 2 X D Studs - metal end ~ 2 X D Goujons, filetés avec longueur d'implantation ~ 2 X D	DIN 835	110 - 111
	Verschlusschrauben mit kegeligem Gewinde und Innensechskant Hexagon socket pipe plugs, conical thread Bouchons filetés coniques à six pans creux	DIN 906	112 - 113

1

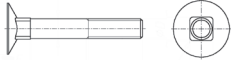

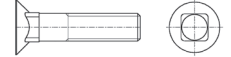
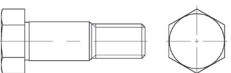
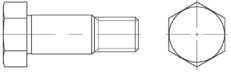
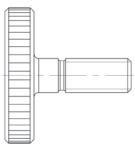
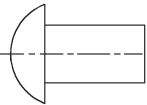
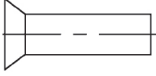
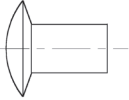
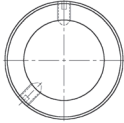
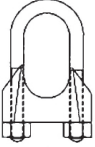
2

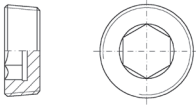

3



4



5



6



7



8



9









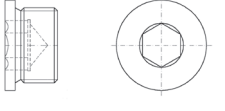

Abbildung	Bezeichnung	Norm	Seite
 	<p>Verschlusschrauben mit Bund und Innensechskant Hexagon socket screw plugs, cylindrical thread Bouchons filetés cylindriques à six pans creux avec embase</p>	DIN 908	114 - 115
 	<p>Verschlusschrauben mit Außensechskant Hexagon head screw plugs, conical thread Bouchons filetés coniques à tête hexagonale</p>	DIN 909	-
 	<p>Verschlusschrauben mit Bund und Außensechskant Hexagon head screw plugs, heavy type, cylindrical thread Bouchons filetés à tête hexagonale et embase - bouchons de carter</p>	DIN 910	116 - 117
 	<p>Stiftschlüssel Hexagon socket screw keys Clés pour vis à six pans creux</p>	DIN 911	465
 	<p>Zylinderschrauben mit Innensechskant Hexagon socket head cap screws Vis à tête cylindrique à six pans creux - CHC</p>	DIN 912	118 - 119
 	<p>Gewindestifte mit Innensechskant und Kegelkuppe Hexagon socket set screws with flat point Vis sans tête, entièrement filetées à six pans creux, bout plat</p>	DIN 913	120 - 121
 	<p>Gewindestifte mit Innensechskant und Spitze Hexagon socket set screws with cone point Vis sans tête, entièrement filetées à six pans creux, bout pointeau</p>	DIN 914	122 - 123

Abbildung	Bezeichnung	Norm	Seite
	Gewindestifte mit Innensechskant und Zapfen Hexagon socket set screws with dog point Vis sans tête, entièrement filetées à six pans creux, à téton	DIN 915	124 - 125
	Gewindestifte mit Innensechskant und Ringschneide Hexagon socket set screws with cup point Vis sans tête, entièrement filetées à six pans creux, bout cuvette	DIN 916	126 - 127
	Sechskant-Hutmuttern niedrige Form Hexagon cap nuts, low type Ecrous borgnes hexagonaux bas	DIN 917	278
	Flachkopfschrauben mit Schlitz und kleinem Kopf Slotted pan head screws with small head Vis à tête cylindrique réduite, fendue	DIN 920	128
	Flachkopfschrauben mit Schlitz und großem Kopf Slotted pan head screws with large head Vis à grande tête cylindrique plate, fendue	DIN 921	129
	Flachkopfschrauben mit Schlitz und Ansatz Slotted pan head screws with shoulder Vis à tête cylindrique fendue, axe épaulé	DIN 923	130
	Gewindestifte mit Schlitz und Zapfen Slotted set screws with dog point Vis sans tête fendue, à téton	DIN 926	-

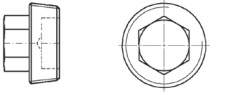

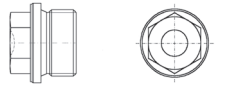
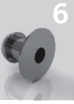

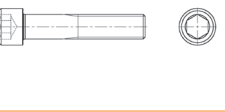
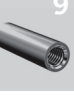
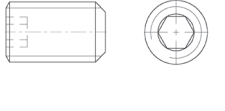

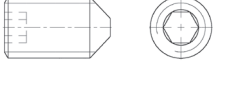

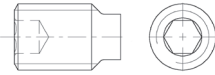
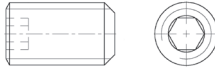
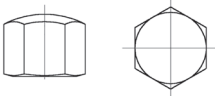
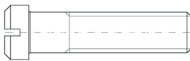
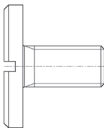
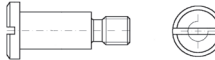
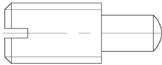
Abbildung	Bezeichnung	Norm	Seite
	Zapfenschrauben mit Schlitz Slotted shoulder screws Vis sans tête fendue	DIN 927	131
	Vierkant-Schweißmuttern Square weld nuts Ecrous carrés à souder	DIN 928	279
	Sechskant-Schweißmuttern Hexagon weld nuts Ecrous hexagonaux à souder	DIN 929	280
	Sechskantschrauben mit Schaft Hexagon head bolts Vis à tête hexagonale, filetage partiel - vis TH	DIN 931 ISO 4014	132 - 133 189
	Sechskantschrauben mit Gewinde bis Kopf Hexagon head screws Vis à tête hexagonale, filetage total - vis TH	DIN 933 ISO 4017	134 - 135 189
	Sechskantmuttern Hexagon nuts Ecrous hexagonaux	DIN 934	281
	Kronenmuttern Hexagon slotted and castle nuts Ecrous hexagonaux à créneaux	DIN 935	282



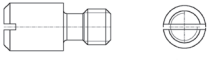
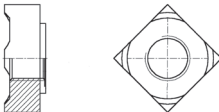
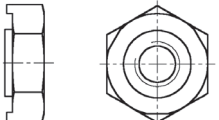

Abbildung	Bezeichnung	Norm	Seite
	<p>Sechskantmutter niedrige Form Hexagon thin nuts Ecrous hexagonaux, forme basse</p>	DIN 936	283
	<p>Kronenmutter niedrige Form Hexagon thin slotted and castle nuts Ecrous hexagonaux à créneaux, forme basse</p>	DIN 937	284
	<p>Stiftschrauben Einschraubende ca. 1 X D Studs - metal end ~ 1 X D Goujons filetés, longueur vissée ~ 1 X D</p>	DIN 938	136 - 137
	<p>Stiftschrauben Einschraubende ca. 1,25 X D Studs - metal end ~ 1,25 X D Goujons filetés, longueur vissée ~ 1,25 X D</p>	DIN 939	138 - 139
	<p>Stiftschrauben Einschraubende ca. 2,5 X D Studs - metal end ~ 2,5 X D Goujons filetés, longueur vissée ~ 2,5 X D</p>	DIN 940	-
	<p>Sechskantschrauben mit Schaft und metrischem Feingewinde Hexagon head bolts, metric fine pitch thread Vis à tête hexagonale, filetage partiel au pas fin</p>	DIN 960	140 - 141
	<p>Sechskantschrauben mit Vollgewinde und metrischem Feingewinde Hexagon head screws, metric fine pitch thread Vis à tête hexagonale, filetage total au pas fin</p>	DIN 961	142 - 143

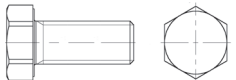

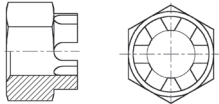



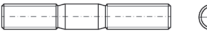
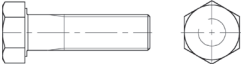
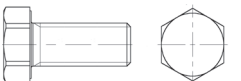

Abbildung	Bezeichnung	Norm	Seite
	Senkschrauben mit Schlitz Slotted countersunk (flat) head screws Vis à tête fraisée fendue	DIN 963	144 - 145
	Linsensenkschrauben mit Schlitz Slotted raised countersunk (oval) head screws Vis à tête fraisée bombée fendue	DIN 964	146 - 147
	Senkschrauben mit Kreuzschlitz Cross recessed countersunk (flat) head screws Vis à tête fraisée à empreinte cruciforme	DIN 965	148 - 149
	Linsensenkschrauben mit Kreuzschlitz Cross recessed raised countersunk head screws Vis à tête fraisée bombée à empreinte cruciforme	DIN 966	150 - 151
	Gewindestangen Threaded rods - threaded pins Tiges filetées - bout filetés	DIN 976	152 - 153
	Kronenmuttern niedrige Form Hexagon thin slotted and castle nuts Ecrus hexagonaux à créneaux , forme basse	DIN 979	285
	Sechskantmuttern mit Klemmteil Ganzmetallmuttern Prevailing torque type hexagon nuts, all-metal nuts Ecrus freins hexagonaux, tout métal	DIN 980	286

Abbildung	Bezeichnung	Norm	Seite
	Nutmuttern für Wälzlager Locknuts for rolling bearings Ecrous cylindriques à encoches	DIN 981	287 - 288
	Sechskantmuttern mit Klemmteil, nicht-metallischer Einsatz, hohe Form Prevailing torque type hexagon nuts with non-metallic insert, high type Ecrous freins hexagonaux - bague nylon, forme haute	DIN 982	289
	Sicherungsringe mit Lappen für Wellen Retaining rings with lugs for shafts Circlips extérieurs à ailerons type „K“ pour arbre	DIN 983	-
	Sicherungsringe mit Lappen für Bohrungen Spring retaining rings with lugs for use in bores (internal circlips) Circlips extérieurs à ailerons type „K“ pour alésage	DIN 984	-
	Sechskantmuttern mit Klemmteil, nicht-metallischer Einsatz Prevailing torque type hexagon thin nuts with non-metallic insert Ecrous freins hexagonaux - bague nylon	DIN 985	290
	Sechskant-Hutmuttern mit Klemmteil, nichtmetallischer Einsatz Prevailing torque type hexagon domed cap nuts with non-metallic insert Ecrous borgnes autofreinés - bague nylon	DIN 986	291
	Passscheiben / Stützscheiben Shim rings and supporting rings Rondelles de calage	DIN 988	346 - 349







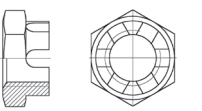
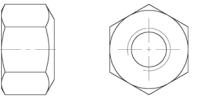

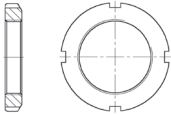
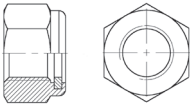
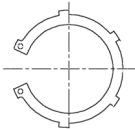
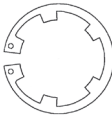
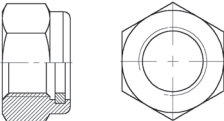
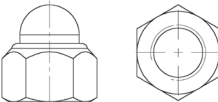
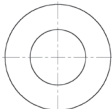

Abbildung	Bezeichnung	Norm	Seite
	Scheiben großer Außendurchmesser für Holzbau Washers, especially for timber constructions Rondelles extra large pour constructions en bois	DIN 1052	350
	Holzverbinder Timber connectors Connecteurs à bois	DIN 1052	-
	Leichtbauplatten-Stifte Nails for light-weight building slabs Pointes - clous pour panneaux légers	DIN 1144	400
	Drahtstifte mit Senkkopf Round plain head nails Pointes - clous à tête fraisée	DIN 1151	401
	Drahtstifte mit Stauchkopf Round nails with cold headed head Pointes - clous à tête ronde	DIN 1152	402
	Bolzen ohne Kopf Clevis pins without head Goujons sans tête - axes d'articulation	DIN 1433	444
	Bolzen kleiner Kopf, Ausführung m Clevis pins with small head Goujons à tête réduite - axes d'articulation	DIN 1434	445



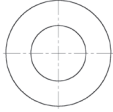

Abbildung	Bezeichnung	Norm	Seite
	Bolzen kleiner Kopf, Ausführung mg Clevis pins with small head Goujons à tête réduite - axes d'articulation	DIN 1435	446
	Bolzen großer Kopf Clevis pins with large head Goujons à tête large - axes d'articulation	DIN 1436	447
	Scheiben Ausführung mittel für Bolzen Plain washers for clevis pins Rondelles moyennes pour axes d'articulation	DIN 1440	351
	Scheiben Ausführung grob für Bolzen Washers for clevis pins Rondelles pour axes d'articulation	DIN 1441	352
	Passkerbstifte mit Hals Grooved pins, half length grooved with gorge Goupilles cannelées d'ajustage avec gorge	DIN 1469	-
	Zylinderkerbstifte mit Einführende Grooved pins parallel grooved, with pilot Goupilles cannelées à cannelures constantes sur toute la longueur (débouchantes), à bout pilote	DIN 1470	403
	Kegelkerbstifte Grooved pins, full length taper grooved Goupilles coniques cannelées (cannelures progressives sur toute la longueur)	DIN 1471	404







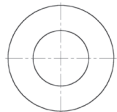
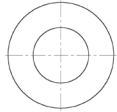

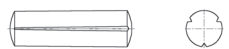
Abbildung	Bezeichnung	Norm	Seite
<p>1</p> 	<p>Passkerbstifte Grooved pins - half-length taper grooved Goupilles coniques semi-cannelées (cannelures progressives sur la demi longueur)</p>	DIN 1472	405
<p>2</p> 	<p>Zylinderkerbstifte mit Fase Grooved pins, full length parallel groo- ved with chamfer Goupilles cylindriques cannelées (cannelure centrale constante sur toute la longueur)</p>	DIN 1473	406 - 407
<p>3</p> 	<p>Steckkerbstifte Grooved pins, half length reserve grooved Goupilles cannelées embrochable (cannelures progressives renversées sur la demi longueur)</p>	DIN 1474	408
<p>4</p> 	<p>Knebelkerbstifte mit kurzen Kerben Grooved pins - one-third-length centre grooved Goupilles cannelées bombées (cannelures centrales constantes sur la tiers de la longueur non débouchantes)</p>	DIN 1475	409
<p>5</p> 	<p>Halbrundkerbnägel Grooved pins with round head Clous cannelés à tête ronde</p>	DIN 1476	410
<p>6</p> 	<p>Senkernbnägel Grooved pins with countersunk head Clous cannelés à tête fraisée</p>	DIN 1477	411
<p>7</p> 	<p>Spannschlossmuttern aus Stahlrohr Turnbuckles made from steel tubes or round steel bars Tendeurs cylindriques</p>	DIN 1478	292



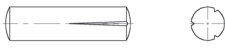



Abbildung	Bezeichnung	Norm	Seite
	Spannschlossmuttern aus Sechskantstahl Hexagon turnbuckles Ecrous de tension	DIN 1479	293
	Spannschlösser geschmiedet (offene Form) Turnbuckles Tendeurs avec crochets, oeils ou bouts à souder	DIN 1480	294
	Sechskant-Hutmuttern hohe Form Hexagon domed cap nuts, high type Ecrous borgnes, forme haute	DIN 1587	295
	Nutmuttern Slotted round nuts for hook spanner Ecrous cylindriques à encoches - ecrous à créneaux	DIN 1804	296 - 297
	Kreuzlochmuttern Round nut with set pin holes inside Ecrous cylindriques percés en croix	DIN 1816	298
	Tellerfedern Hexagon socket head cap screws with centre, with low head Rondelles ressort - rondelles „belleville“	DIN 2093	353 - 355
	Schraubbolzen Double End Studs Boulons filetés à tige amincie	DIN 2509	-

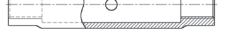

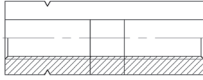

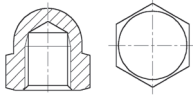

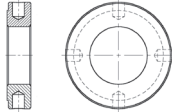

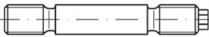
Abbildung	Bezeichnung	Norm	Seite
	Schraubbolzen mit Dehnschaft Double End Studs Boulons filetés à tige amincie	DIN 2510	-
	Rundstahlbügel Form A Steel strap for tubes Étrier en acier rond pour tuyaux	DIN 3570	466
	Sicherungsbleche für Nutmuttern Lock washers for locknuts Rondelles de blocage type MB	DIN 5406	356 - 357
	Sprengringe Snap rings for bearings with ring groove Anneaux expansifs type SP	DIN 5417	-
	Kugelscheiben Form C Spherical washers convex (type C) Rondelles articulées convexe (forme C)	DIN 6319	-
	Kegelpfannen Form D und G Conical seats (type D and G) Rondelles articulées concave (forme D et G)	DIN 6319	-
	Zylinderstifte gehärtet und geschliffen Parallel pins, hardened Goupilles cylindriques (trempées et rectifiées)	DIN 6325	412 - 413

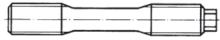

Abbildung	Bezeichnung	Norm	Seite
	<p>Sechskantmuttern 1,5 X D hoch Hexagon nuts with a height of 1,5 X D Ecrrous hexagonaux, forme haute, 1,5 X D</p>	DIN 6330	299
	<p>Sechskantmuttern 1,5 X D hoch mit Bund Hexagon collar nuts with a height of 1,5 X D Ecrrous hexagonaux à embase, forme haute, 1,5 X D</p>	DIN 6331	300
	<p>Verlängerungsmuttern mit Sechskant, 3 X D hoch Extension nuts with a height of 3 X D Entretroises hexagonales, 3 X D</p>	DIN 6334	301
	<p>Kreuzgriffe Palm grips Volants croisillons</p>	DIN 6335	467
	<p>Sterngriffe Star grips Volants étoiles</p>	DIN 6336	468 - 469
	<p>Scheiben für Spannzeuge Washers for clamping devices Rondelles plate renforcées</p>	DIN 6340	358
	<p>Stiftschrauben für T-Nutensteine Studs for use with T-nuts Goujons filetés pour écrous pour rainures en T</p>	DIN 6379	-

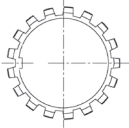





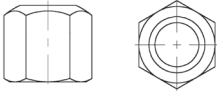

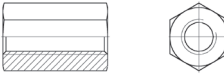
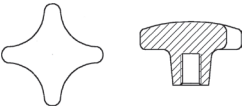
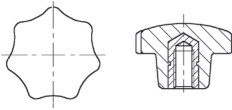
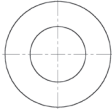
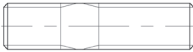

Abbildung	Bezeichnung	Norm	Seite
	Spannscheiben für Schraubenverbindungen Conical spring washers for bolted connections Rondelles élastiques coniques	DIN 6796	359
	Zahnscheiben Form A / Form I Toothed lock washers external (type A) or internal (type I) Rondelles dentées extérieures (forme A) ou intérieures (forme I)	DIN 6797	360
	Zahnscheiben Form V Toothed lock washers (type V) Rondelles dentées à dents extérieures coniques (forme V)	DIN 6797	361
	Fächerscheiben Form A / Form I Serrated lock washers external (type A) or internal (type I) Rondelles éventails à dents extérieures (forme A) ou intérieures (forme I)	DIN 6798	362
	Fächerscheiben Form V Serrated lock washers (type V) Rondelles éventails à dents extérieures coniques (forme V)	DIN 6798	363
	Sicherungsscheiben für Wellen Lock washers (retaining washers) for shafts Anneaux d'arrets pour arbres	DIN 6799	364
	Keilstahl Key steel Barres à clavette	DIN 6880	-

Abbildung	Bezeichnung	Norm	Seite
	Passfedern Form A: rundstirnig Parallel keys (type A) Clavettes (forme A)	DIN 6885	414 - 421
	Passfedern Form B: geradstirnig Parallel keys (type B) Clavettes (forme B)	DIN 6885	-
	Nasenkeile Taper keys with gip head Clavettes à talon	DIN 6887	422
	Einlegekeile Wedges Cales	DIN 6886	-
	Scheibenfedern Woodruff keys Clavettes disques	DIN 6888	423
	Kauschen Form A Wire thimbles (type A) Cosses coeur (forme A)	DIN 6899	470
	Zylinderschrauben Innensechskant niedriger Kopf mit Schlüsselführung Hexagon socket head cap screws with centre hole and low head Vis à tête cylindrique six pans creux, forme basse	DIN 6912	154 - 155

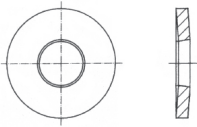
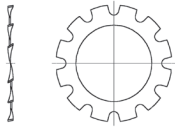
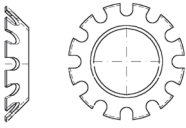
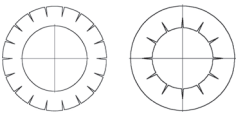
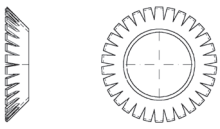
1

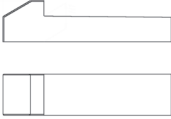
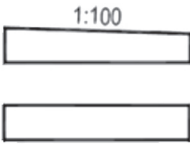
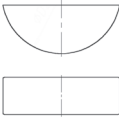

2



3



4



5



6



7



8



9





1

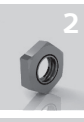

2



3



4



5



6



7



8



9





Abbildung	Bezeichnung	Norm	Seite
	<p>HV-Vierkantscheiben I-Profil Square taper washers for high-strength structural bolting of steel I-sections Cales biaisées pour profils I pour constructions métalliques</p>	DIN 6917	365
	<p>HV-Vierkantscheiben U-Profil Square taper washers for high-strength structural bolting of steel channel sections Cales biaisées pour profils U pour constructions métalliques</p>	DIN 6918	366
	<p>Sechskantschrauben mit Flansch Hexagon flange bolts Vis à six pans avec embase</p>	DIN 6921	156
	<p>Sechskantmuttern mit Flansch Hexagon nuts with flange Ecrous hexagonaux à embase</p>	DIN 6923	302
	<p>Sechskantmuttern mit Klemmteil, nicht-metallischer Einsatz Prevailing torque type hexagon nuts (with non-metallic insert) Ecrous freins hexagonaux avec anneau non-métallique</p>	DIN 6924	303
	<p>Sechskantmuttern mit Klemmteil Ganzmetallmuttern Prevailing torque type all-metal hexagon nuts Ecrous freins hexagonaux tout métal</p>	DIN 6925	304
	<p>Sechskantmuttern mit Flansch und Klemmteil nichtmetallischer Einsatz Prevailing torque type hexagon nuts with flange (with non-metallic insert) Écrous freins hexagonaux à embase avec anneau non-métallique</p>	DIN 6926	305

Abbildung	Bezeichnung	Norm	Seite
	<p>Sechskantmutter mit Flansch mit Klemmteil Ganzmetallmutter Prevailing torque type all-metal hexagon nuts with flange Ecrous freins hexagonaux à embase entièrement en métal</p>	DIN 6927	-
	<p>Blindnieten Flachkopf Blind rivet – standard Rivets aveugles – tête plate</p>	DIN 7337	456
	<p>Blindnieten Senkkopf Blind rivet – countersunk Rivets aveugles – tête fraise</p>	DIN 7337	457
	<p>Nieten für Brems- und Kupplungsbeläge Rivets for brake linings and clutch linings Rivets pour garnitures de frein et dembrayage</p>	DIN 7338	-
	<p>Rohrnieten Tubular rivets Rivets tubulaires</p>	DIN 7340	-
	<p>Spannhülse leichte Ausführung Spring-type straight pins - slotted, light duty Goupilles cylindriques creuses, dites goupilles élastiques - série mince</p>	DIN 7346	424 - 425
	<p>Scheiben für Schrauben mit schweren Spannhülsen Plain washers for bolts with heavy clamping sleeves Rondelles pour vis avec goupilles élastiques renforcées</p>	DIN 7349	367



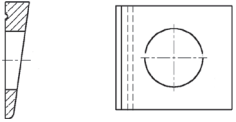
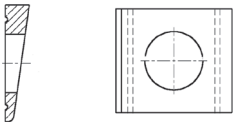

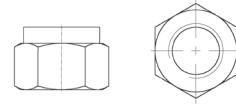
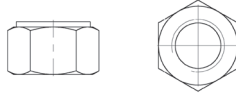

Abbildung	Bezeichnung	Norm	Seite
	Gewindefurchende Schrauben mit Linsenkopf Thread rolling screws for metric ISO thread with pan head Vis autotaraudeuses, tête bombée	DIN 7500-C	157
	Gewindefurchende Schrauben mit Sechskantkopf Thread rolling screws for metric ISO thread with hexagon head Vis autotaraudeuses, tête hexagonale	DIN 7500-D	158
	Gewindefurchende Schrauben mit Zylinderkopf Thread rolling screws for metric ISO thread with hexagon socket head Vis autotaraudeuses, tête cylindrique 6 pans	DIN 7500-E	159
	Gewindefurchende Schrauben mit Senkkopf Thread rolling screws for metric ISO thread with countersunk head Vis autotaraudeuses, tête fraisée cruciforme	DIN 7500-M	160
	Blechbohrschrauben mit Sechskant Self drilling screws with tapping screw thread with hexagon head Vis auto-perceuses, tête hexagonale	DIN 7504-K	161
	Blechbohrschrauben mit Flachkopf und Kreuzschlitz Self drilling screws with tapping screw thread with pan head Vis auto-perceuses, tête bombée	DIN 7504-N	162 - 163
	Blechbohrschrauben mit Senkkopf und Kreuzschlitz Self drilling screws with tapping screw thread with countersunk head Vis auto-perceuses, tête fraisée	DIN 7504-P	164

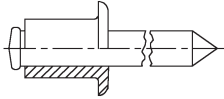
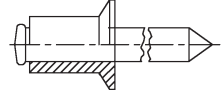
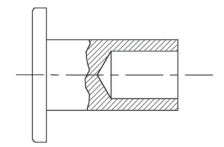
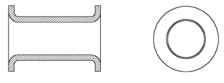
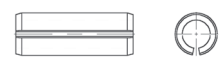
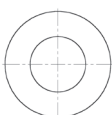
Abbildung	Bezeichnung	Norm	Seite
	<p>Blechbohrschrauben mit Linsensenk- kopf und Kreuzschlitz Self drilling screws with tapping screw thread with raised countersunk (oval) head Vis auto-perceuses, tête fraisée bombée</p>	DIN 7504-Q	-
	<p>Gewinde-Schneidschrauben mit Sechskantkopf Thread cutting screws with hexagon head Vis autotaraudeuse, tête hexagonale</p>	DIN 7513-A	165
	<p>Gewinde-Schneidschrauben mit Zylinderkopf Thread cutting screws with hexagon socket head Vis autotaraudeuses, tête cylindrique fendue</p>	DIN 7513-B	166
	<p>Gewinde-Schneidschrauben mit Senkkopf Thread cutting screws with countersunk head Vis autotaraudeuses, tête fraisée fendue</p>	DIN 7513-F	167
	<p>Gewinde-Schneidschrauben mit Linsen- senkopf Thread cutting screws with pan head Vis autotaraudeuses, tête bombée</p>	DIN 7516-A	168
	<p>Gewinde-Schneidschrauben mit Senkkopf Thread cutting screws with countersunk head Vis autotaraudeuses, tête fraisée</p>	DIN 7516-D	169
	<p>Gewinde-Schneidschrauben mit Linsen- senkkopf Thread cutting screws with raised coun- tersunk (oval) head Vis autotaraudeuses, tête fraisée bom- bée cruciforme</p>	DIN 7516-E	-





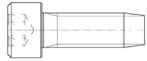
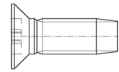
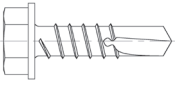
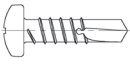
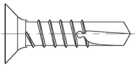

Abbildung	Bezeichnung	Norm	Seite
	Dichtringe Form A Sealing rings Joints d'étanchéité	DIN 7603	368 - 370
	Verschlusschrauben mit Außensechskant Hexagon head screw plugs, light type, cylindrical thread Bouchons filetés tête hexagonale à embase	DIN 7604	-
	Einschraubmuttern Rampamuffen Screwed inserts Ecrous à visser pour bois	DIN 7965	488 - 489
	Sicherungsmuttern „Palmmuttern“ Self locking counter nuts „PAL“ Ecrous de sécurité „PAL“	DIN 7967	306
	Sechskant-Passschrauben Hexagon fit bolts with hexagon nut, for steel structures Boulons d'ajustage pour constructions métalliques	DIN 7968	-
	Senkschrauben mit Schlitz Slotted countersunk head bolts with hexagon nut, for steel structures Vis à tête fraisée fendue pour constructions métalliques	DIN 7969	-
	Blechschraben mit Flachkopf und Schlitz Slotted pan head tapping screws Vis à tôle, tête cylindrique, fendue	DIN 7971	170

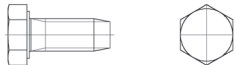
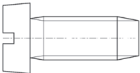
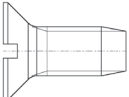
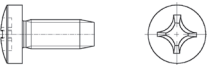
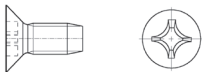
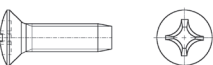



Abbildung	Bezeichnung	Norm	Seite
	Blechschauben mit Senkkopf und Schlitz Slotted countersunk head tapping screw Vis à tôle, tête fraisée, fendue	DIN 7972	171
	Blechschauben mit Linsensenkkopf und Schlitz Slotted raised countersunk (oval) head tapping screws Vis à tôle, tête fraisée bombée, fendue	DIN 7973	172
	Blechschauben mit Sechskant Hexagon head tapping screws Vis à tôle, tête hexagonale	DIN 7976	173
	Kegelstifte mit Gewindezapfen Taper pins with external thread Goupilles coniques à téton fileté (non trempées)	DIN 7977	426 - 427
	Kegelstifte mit Innengewinde Taper pins with internal thread Goupilles coniques avec trou taraudé (non trempées)	DIN 7978	428 - 429
	Zylinderstifte mit Innengewinde Parallel pins with internal thread Goupilles cylindriques avec trou taraudé (trempées et rectifiées)	DIN 7979	430 - 431
	Federringe für Zylinderschrauben Spring lock washers for screws with cylindrical head Rondelles ressort „grower“	DIN 7980	371



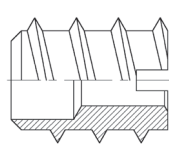
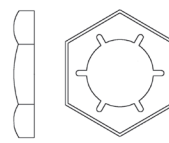
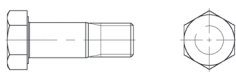
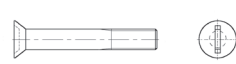
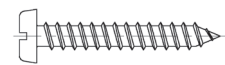

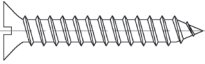
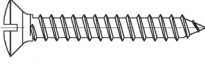
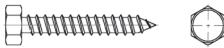

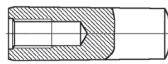

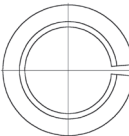

Abbildung	Bezeichnung	Norm	Seite
	Blechschauben mit Flachkopf und Kreuzschlitz Cross recessed pan head tapping screws Vis à tôle, tête cylindrique bombée large à empreinte cruciforme	DIN 7981	174
	Blechschauben mit Senkkopf und Kreuzschlitz Cross recessed countersunk head tapping screws Vis à tôle, tête fraisée à empreinte cruciforme	DIN 7982	175
	Blechschauben mit Linsensenkopf und Kreuzschlitz Cross recessed raised countersunk (oval) head tapping screws Vis à tôle, tête fraisée bombée à empreinte cruciforme	DIN 7983	176 - 177
	Zylinderschrauben mit Innensechskant und niedrigem Kopf Hexagon socket head cap screws with low head Vis à tête cylindrique six pans creux, forme basse	DIN 7984	178 - 179
	Flachkopfschrauben mit Kreuzschlitz Cross recessed pan head screws Vis à métaux, tête cylindrique bombée à empreinte cruciforme	DIN 7985	180 - 181
	Scheiben für Stahlkonstruktionen Flat washers for steel structures Rondelles plates pour constructions métalliques	DIN 7989	372
	Sechskantschrauben mit Sechskantmutter für Stahlkonstruktionen Hexagon head bolts for steel structures Boulons pour constructions métalliques	DIN 7990	182 - 185



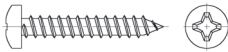

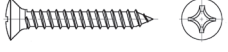
Abbildung	Bezeichnung	Norm	Seite
	Senkschrauben mit Innensechskant Hexagon socket countersunk head screws Vis à métaux, tête fraisée à six pans creux - FHC	DIN 7991 ISO 10642	186 - 187
	Hammerschrauben Eye bolts Vis à oeil	DIN 7992	-
	Runddrahtsprengringe für Wellen Form A wire rings for shafts (type A) Jonc d'arrêt pour arbre (forme A)	DIN 7993	373 - 374
	Runddrahtsprengringe für Bohrungen Form B Snap rings for bores (type B) Jonc d'arrêt pour arbre (forme B)	DIN 7993	375
	Linsensenkholzschrauben mit Kreuzschlitz Cross recessed raised countersunk head wood screws Vis à bois à tête fraisée bombée cruciforme	DIN 7995	188
	Halbrundholzschrauben mit Kreuzschlitz Cross recessed pan head wood screws Vis à bois à tête demi-ronde cruciforme	DIN 7996	-
	Senkholzschrauben mit Kreuzschlitz Cross recessed countersunk head wood screws Vis à bois à tête fraisée cruciforme	DIN 7997	-

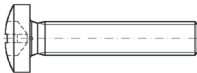

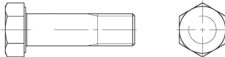
Abbildung	Bezeichnung	Norm	Seite
	<p>Gewindeinsatz Wire thread inserts Filets rapportés</p>	<p>DIN 8140</p>	<p>490 - 492</p>
	<p>Scheiben Außendurchmesser = 3 X Gewindedurchmesser Washers with outside diameter = 3 X thread diameter Rondelles larges avec diamètre extérieur = 3 X diamètre int.</p>	<p>DIN 9021</p>	<p>376</p>
	<p>Federstecker Spring cotters Goupilles ressort double</p>	<p>DIN 11024</p>	<p>448</p>
	<p>Thermagmutter normale Schlüsselweite Exhaust slotted nuts Ecrou d'échappement fendu en acier cuivré</p>	<p>DIN 14440</p>	<p>307</p>
	<p>Thermagmutter verringerte Schlüssel- weite Exhaust slotted nuts Ecrou d'échappement fendu en acier cuivré</p>	<p>DIN 14441</p>	<p>308</p>
	<p>Structural Bolt Nicht vorgespannte Schraubenverbindung Non-preloaded structural bolting assemblies non pré-contraints Structural Bolts</p>	<p>DIN EN 15048</p>	<p>190-191</p>
	<p>Dreikantschrauben Triangle head bolts Vis à tête triangulaire à embase cylin- drique</p>	<p>DIN 22424</p>	<p>-</p>

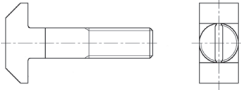
Abbildung	Bezeichnung	Norm	Seite
	Schweißbolzen mit Außengewinde und Spitzenzündung Welding studs Goujons à souder	DIN 32501	-
	Nutmuttern	DIN 70851	-
	Nutmuttern	DIN 70852	309
	Hakensprengringe Snap rings with hook Circlip avec crochet	DIN 70951	-
	Schmiernippel Lubricating nipples cone type Graisseurs	DIN 71412	-
	Gabelgelenke Form A: mit Splintbolzen Fork joints (type A) Chapes complètes (forme A)	DIN 71751	471
	Gabelköpfe für Gabelgelenke Yokes Chapes	DIN 71752	472

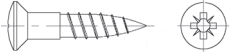
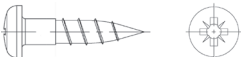



Abbildung	Bezeichnung	Norm	Seite
	Flache Muttern mit kleiner Schlüsselweite Thin Conduit Panel Nut Écrous plats	DIN 80705	-
	Schäkel Shackles Manilles	DIN 82101	473
	Schulterpassschrauben mit Innensechskant Hexagon socket head shoulder screws Vis à épaulement cylindriques à six pans creux	ISO 7379	192
	Flachkopfschrauben mit Innensechskant Hexagon socket button head screws Vis à tête bombée à six pans creux - BHC	ISO 7380	193
	Linienflanschschraben mit Innensechskant Hexagon socket button head screws with flange Vis à tête bombée à six pans creux avec embase - BHC	ISO 7380F	194 - 195
	Spiralspannstifte schwere Ausführung Spring-type straight pins - coiled, heavy duty Goupilles élastiques spiralées, série épaisse	ISO 8748	432 - 433
	Spiralspannstifte normale Ausführung Spring-type straight pins - coiled, standard duty Goupilles élastiques spiralées, série moyenne	ISO 8750	434 - 435

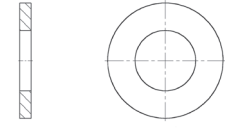
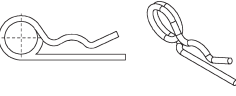
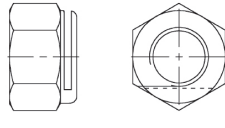
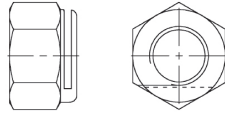
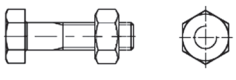
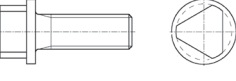

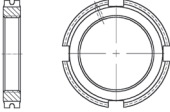
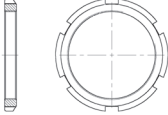
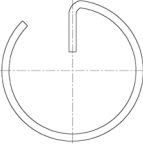
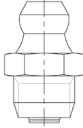
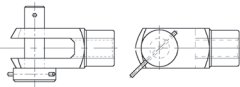
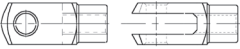

Abbildung	Bezeichnung	Norm	Seite
	Spannstifte geschlitzte, schwere Ausführung Spring-type straight pins - slotted, heavy duty Goupilles cylindriques élastiques, série épaisse	ISO 8752	436 - 437
	Sechskantschrauben für HV-Verbindungen Hexagon bolts with large widths across flats for high tensile structural bolting Vis à tête hexagonales à serrage contrôlé haute résistance pour constructions métalliques - vis HV	DIN EN 14399-4	196 - 199
	Sechskantmuttern für HV-Verbindungen Hexagon nuts for high-strength structural bolting assemblies for preloading Ecrous hexagonaux haute résistance pour constructions métallique - écrou HV	DIN EN 14399-4	311
	Scheiben für HV-Verbindungen Plain chamfered washers for high-strength structural bolting assemblies for preloading Rondelles plates haute résistance pour constructions métalliques - rondelle HV	DIN EN 14399-6	377
	Passschrauben für HV-Verbindungen High tensile strength hexagon fit bolts Vis à épaulement pour constructions métalliques	DIN EN 14399-8	-
	Zylinderschrauben mit Innensechsrund Hexalobular socket cheese head screws Vis à métaux, tête cylindrique à six lobes internes, tête basse	ISO 14580	200
	Senkschrauben mit Innensechsrund Hexalobular socket countersunk flat head screws Vis à métaux, tête fraisée à six lobes internes	ISO 14581	201



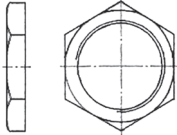
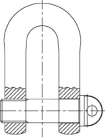
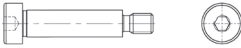
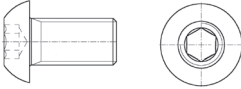
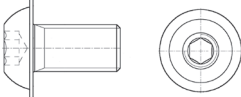
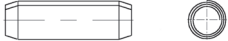
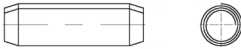



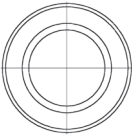
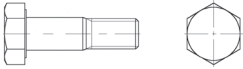



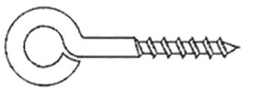

Abbildung	Bezeichnung	Norm	Seite
	Kontaktscheiben gezahnt Contact washers Rondelles contact	ART55	378
	Ringschrauben Lifting eye bolts Vis - pitons pour bois	A001	202 - 203
	Starke Ringschrauben Lifting eye, heavy duty Vis - pitons pour bois, serie lourde	A002	204
	Sturmhakenösen Screw eyes for gate hooks Vis - pitons pour crochets de contre-vents	A003	205
	Gerade Schraubhaken Square hooks Gonds à vis, filetage bois	A004	206
	Gerade Schraubhaken mit ISO-Gewinde Square hooks with ISO-thread Gonds à vis, filetage métrique	A004E	207
	Schlitzschraubhaken Square hooks with slit Gonds à vis avec fente	A007	208

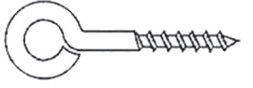
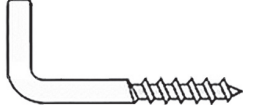
Abbildung	Bezeichnung	Norm	Seite
	Gebogene Schraubhaken Cup hooks Crochets d'armoires, filetage bois	A011	209
	Gebogene Schraubhaken mit ISO-Gewinde Cup hooks with ISO-thread Crochets d'armoires, filetage métrique	A011E	210
	Kronleuchterhaken Ceiling hooks Crochets à lustre	A013	211
	Wäscheleinhaken Clothes-line-hooks Crochets pour cordes à linge	A015	212
	Deckenhaken Ceiling hooks Crochets pour plafond	A017	213
	Kettenschnellverschlüsse Quick-release links Maillons rapides	A044	-
	S-Haken S-Hooks Crochets en S	A045	-

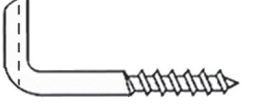
1

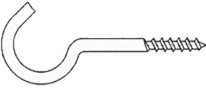

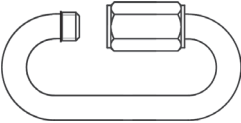
2



3



4



5



6



7



8



9











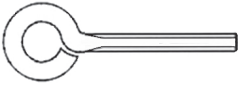

Abbildung	Bezeichnung	Norm	Seite
	Ringschrauben mit ISO-Gewinde Eye bolts with ISO-thread Vis - pitons, filetage métrique	A048	214 - 215
	Feuerwehr Karabinerhaken ähnlich: DIN 5299 Form C Snap hooks ~ DIN 5299 type C Mousquetons ~ DIN 5299 forme C	A0245	-
	Schrauben mit Schließkopf (Sicherheits- schrauben) Safety screws with aluminium plug Vis de sécurité avec bouchon en aluminium	E0601	-
	Kontaktscheibe Contact washers Rondelle conique striée de serrage série moyenne	NFE 25511	393
	Mauerschrauben Concrete screws Vis béton	-	-
	Flachkopfschrauben Typ KF Flathead Screws Type KF	N0001	223
	Sechskantschutzkappen Plastic protective caps Caches écrous plastiques	N0010	474

Abbildung	Bezeichnung	Norm	Seite
	Kotflügelscheiben Washers for car body Rondelles de carrossier	N0030	379
	Klappsplinte mit rundem Federring Linch pins Goupilles clips	N0040	449
	Rohrklappsplinte Pipe linch pins Goupilles clips pour tube	N0041	450
	Abdeckkappen für Innensechskant Plastic protective caps for hexagon socket head screws Capuchons de protection en plastique pour vis à six pans creux	N0070	475
	Rosetten Countersunk washers Rondelles cuvette	N0080 N0082	380 381
	Rückwandschrauben Screws for backwalls Vis à bois pour panneau arrière (tête large)	N0090	224
	Schnellbauschrauben mit Doppelgang- Feingewinde Drywall screws type 212 Vis placo type 212, pas fin	N0100	225

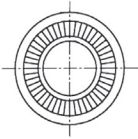
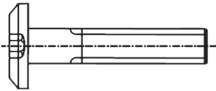
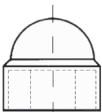

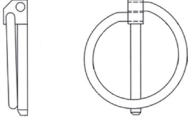
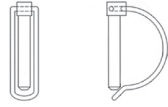

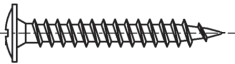



1	Abbildung	Bezeichnung	Norm	Seite
2		Schnellbauschrauben mit Grobgewinde Drywall screws type 121 Vis placo type 121	N0100	226
3		Schnellbauschrauben mit Bohrspitze Drywall screws type 211 Vis placo type 221 avec tête percante	N0100	227
4		SCHNORR Sicherungsscheiben Locking washers - SCHNORR Rondelles de sécurité - SCHNORR	N0110	382 - 383
5		NORD-LOCK Sicherungsscheiben Locking washers - NORD-LOCK Rondelles autobloquante - NORD-LOCK	N0115	384 - 385
6		Stockschrauben Stair bolts Vis doublet filets (bois-métrique)	N0120	228
7		Sperrkantscheiben Form M Security washers Rondelles de sécurité striées	N0125	386
8		Sperrkantringe Form K Locking washers Rondelles de sûreté	N0128	387



Abbildung	Bezeichnung	Norm	Seite
	Messingspreis-Dübel ohne Kugel Brass fixing Fixation en laiton	N0150	-
	Hülsenmuttern mit Senkkopf und Innensechskant Screw post with hexagon socket counter- sunk head Vis de reliure fraisées	N0153	500
	Hülsenmuttern mit Linsensenkkopf und Schlitz Screw post with slotted raised counter- sunk head Vis de reliure fraisées bombées avec fente	N0160	501
	Rundmutter Typ RF Cap Nuts Typ RF	N0163	502
	Distanzhülsen für Balkenschrauben Plastic distance sleeves Entretoise plastiques	N0170	-
	RAMPA-Rundmutter Typ RTL Cap Nuts Type-RTL	N0175	503
	Federnde Druckstücke mit Kugel und Innensechskant HWN2203 Spring Plungers with ball and internal hexagon Poussoirs à bille, six pans creux	N0203	476 - 477





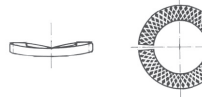

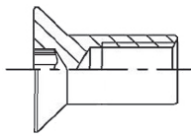
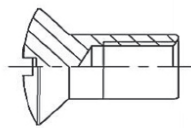
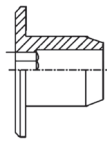
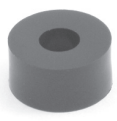

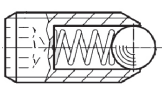

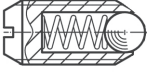

Abbildung	Bezeichnung	Norm	Seite
 	<p>Federnde Druckstücke mit Kugel und Schlitz HWN205S Spring Plungers with ball and slot Poussoirs à bille, fendue</p>	N0205	478 - 479
 	<p>Federnde Druckstücke mit Innensechskant HWN206 Spring Plungers with internal hexagon Poussoirs à bille, ressort renforcé</p>	N0206	480
 	<p>Federnde Druckstücke glatte Ausführung mit Bund Spring Plungers, smooth, with collar and ball Poussoirs, exécution lisse à collerette et bille</p>	N0208	481
 	<p>Federstecker Form 1: einfach gewunden Spring cotters type 1 Goupilles beta simple forme 1</p>	N0240	451
 	<p>Federstecker Form 4: doppelt gewunden spring cotters double spring type 4 Goupilles beta double forme 4</p>	N0240	452
 	<p>Stahlnägel mit Längsriffelung Steel nails Clous striés</p>	N0250	438
 	<p>Dachpappstifte Wide-head roofing nails Clous à tête large</p>	N0252	-

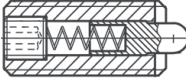
Abbildung	Bezeichnung	Norm	Seite
	Drallhaftschrauben Spiral shank nails Clous filetés torsadés	N0260	439
	Balkonzierschrauben Ornamental balcony screw Vis balcon de décoration	N0270	-
	Rahmenanker Anchor for window frames Vis pour les châssis de fenêtre	N0278	-
	Fensterbauschrauben von EJOT Self drilling screws for synthetical windows - EJOT Vis ejot pour fenêtres - EJOT	N0279	-
	L-Einschlagmuttern Drive-in nuts Ecrous à frapper dans le bois	N0300	314
	L-Anschweißmuttern Weld nut Ecrous à souder	N0301	315
	Setzmuttern Press nuts Ecrous à sertir	N0302	316

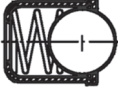
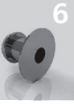
1

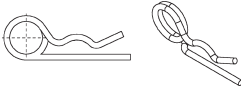

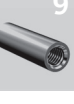
2



3



4



5



6



7



8



9







Abbildung	Bezeichnung	Norm	Seite
	Blindnietmutter Blind rivet nuts Ecrous noyés cylindriques ou hexagonaux	N0310	-
	Federklappbolzen passend zu DIN 71752 Folding spring bolts Goujons à clapet et à ressort	N0365	482
	Distanzmuffen rund, Innengewinde Coupling nuts, round Entretroises cylindriques, filetage intérieur	N0370	504
	Verlängerungsmuffen Sechskant Coupling nuts with hexagon Entretroises hexagonales, filetage intérieur	N0371	505 - 506
	Reduziermuffen mit Innen-/Innengewinde Reducing coupling with two different inside threads Entretroises cylindriques, réducteur de filetage	N0372	507
	Distanzbolzen mit Innen-/Außengewinde Distance bolts with inside and outside thread Entretroises hexagonales, filetage intérieur et extérieur	N0373	510 - 511
	L-Ringe für Wellen (AL) L-rings for shafts (AL) Segments d'arrêt type I pour arbre (AL)	N0400	388





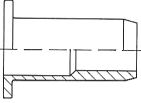
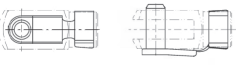
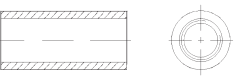
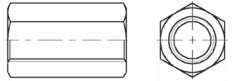
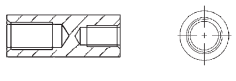
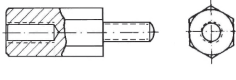

Abbildung	Bezeichnung	Norm	Seite
	V-Ringe für Wellen (AV) V-rings for shafts (AV) Segments extérieurs (AV)	N0400	331
	Greifringe (G) Grip rings for shafts without grooves (G) Bagues serrantes (G)	N0400	-
	Halbmondringe (H) Crescent rings (H) Bagues d'arrêt type croissant (H)	N0400	389
	Klemmscheiben (KS) Circular self locking rings for shafts without grooves (KS) Colliers d'etirement pour arbres sans gorge (KS)	N0400	390
	Sicherungsringe für Bohrung (IL) L-rings for bores (IL) Segments d'arrêt type I pour alésages (IL)	N0400	-
	Zackenringe für Bohrung (ZI) Circular self locking rings for bores (ZI) Rondelles dentelées pour alésages (ZI)	N0400	-
	V-Ringe für Bohrung (IV) V-rings for bores (IV) Segments intérieurs (IV)	N0400	-









Abbildung	Bezeichnung	Norm	Seite
	Sprengringe für Bohrung (SB) Circlips for bores (SB) Anneaux expansifs pour alésages (SB)	N0400	-
	Sprengringe für Wellen (SW) Circlips for shafts (SW) Anneaux expansifs pour arbres (SW)	N0400	-
	Zackenringe für Wellen (ZA) Circular self locking rings for shafts (ZA) Rondelles dentelées pour arbres (ZA)	N0400	-
	LAMA-Rändelköpfe Knurled nuts LAMA Bouchons moletée LAMA	N0410	483
	LAMA-Flügelköpfe Wing nuts LAMA Ecrous à oreilles LAMA	N0430	484
	Käfigmuttern Captive nuts Ecrous en cage	N0440	317
	Blechmuttern Snap nuts Ecrous pour tôle - clips	N0445	-



Abbildung	Bezeichnung	Norm	Seite
	DUBO-Schraubensicherungen DUBOSCHWEITZER - screw lockings DUBOSCHWEITZER - rondelle de sécurité plastique	N0450	391 - 392
	Becherschrauben Slotted truss head machine screws Vis poeliers	N0480	229
	Dichtscheiben gewölbt mit EPDM-Beschichtet Neoprene washers Rondelles néoprènes pour bardage	N0490	-
	Spenglerschrauben Countersunk head wood screws with neoprene washers Vis à bois à tête fraisée bombée avec rondelle néoprène	N0492	230
	Zugstabsystem DETAN Rod system DETAN Système d'haubanage DETAN	N0588	-
	Ketten nach DIN 5685 (G) Chains Chaînes	N0750	485
	Blehschrauben mit Zylinderkopf und Innensechskant Hexagon socket head tapping screws Vis à tôles à tête cylindrique à six pans creux	N0912	231





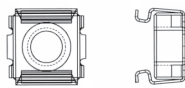
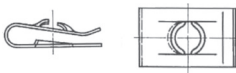

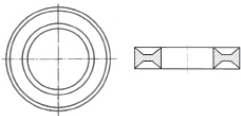
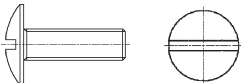
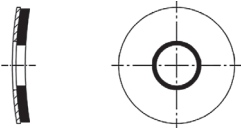
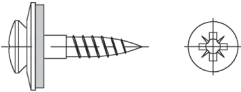
Abbildung	Bezeichnung	Norm	Seite
	Trapezgewindemuttern Sechskant Nuts with trapezoidal thread, hexagon type Ecrous à filetage trapézoïdal, forme hexagonale	N0934	318
	Trapezgewindemuttern rund Nuts with trapezoidal thread, round type Ecrous à filetage trapézoïdal, forme ronde	N0934	319
	Sperrzahn-Schrauben Safety screws with ratchet Vis à tête hexagonale à embase crantée	P151	236 - 237
	Ripp-Schrauben mit Sechskantkopf Safety screws with ripple-profile Vis à tête hexagonale à embase nervurée	P158	238
	Ripp-Muttern Self-locking nuts with ripple profile Ecrou de blocage	P193	321
	Sperrzahn-Muttern Safety nuts with ratchet Ecrous à embase crantée	P196	322
	Inbus-Ripp-Schrauben Safety screws with ripple-profile Vis à tête cylindrique avec nervures	P251	239

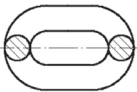
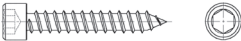

Abbildung	Bezeichnung	Norm	Seite
	SAVETIX-Scheiben SAVETIX washers Rondelles SAVETIX	-	-
	Abreißmuttern	S934	320
	Flachrundkopfschrauben mit Innensechskant-Pin (Sicherheitsschrauben) Buttonhead screws with hexagon socket pin (safety screws) Vis de sécurité en BHC six pans	S7380	-
	Flachrundkopfschrauben mit TORX-Pin (Sicherheitsschrauben) Buttonhead screws with six lobe drive pin (safety screws) Vis de sécurité en BHC TORX	S7380	232
	Blechschrauben mit Flachrundkopf und TORX-Pin (Sicherheitsschrauben) Pan head tapping screws with six lobe drive pin (safety screws) Vis de sécurité cylindriques bombées	S7981	233
	Blechschrauben mit Senkkopf und TORX-Pin (Sicherheitsschrauben) Countersunk head tapping screws with six lobe drive pin (safety screws) Vis de sécurité fraisée TORX	S7982	234
	Senkkopfschrauben mit Innensechskant-Pin (Sicherheitsschrauben) Pin hexagon countersunk head screws (safety screws) Vis de sécurité en FHC six pans	S7991	-



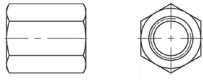
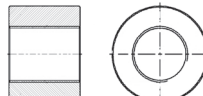
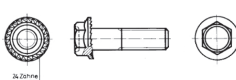
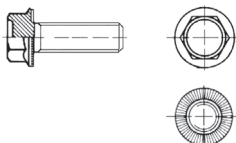
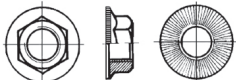
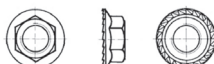



Abbildung	Bezeichnung	Norm	Seite
 	<p>Senkkopfschrauben mit TORX-Pin (Sicherheitsschrauben) Six lobe pin countersunk head screws (safety screws) Vis de sécurité en FHC TORX</p>	S7991	235
	<p>Holzbauschrauben mit Senkkopf und T-Drive Countersunk wood screws - HECO Vis à bois tête fraisée - HECO</p>	TOPIX	252 - 257
	<p>Terrassenbelagschrauben Terrace screws Vis pour terrasse</p>	-	-
	<p>Holzbauschrauben mit Tellerkopfschraube und T-Drive Flange Head Woodscrews - HECO Vis à bois tête bombée large - HECO</p>	TOPIX	258 - 260
	<p>Holzbauschrauben mit Sechskantkopf und T-Drive Hexagon head wood screws - HECO Vis à bois tête hexagonale - HECO</p>	TOPIX	261
	<p>Schrauben für Montageschienen HALFEN T-bolts for mounting rails - HALFEN Boulon avec écrou pour profilés - HALFEN</p>	H	216 - 221
	<p>Gewindeplatten für Montageschienen HALFEN Threaded plates for mounting rails - HALFEN Plaque taraudée pour profilés - HALFEN</p>	H	312 - 313

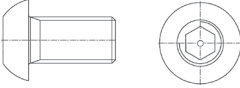
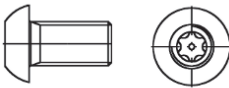
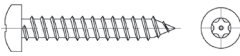
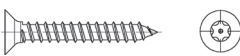
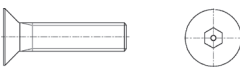

Abbildung	Bezeichnung	Norm	Seite
	Holzbauschrauben HECO Wood screws with contraction effect - HECO UNIX Vis à bois à filetage évolutif - HECO UNIX	UNIX	-
	Fassadenbauschrauben mit EPDM-Dichtscheibe 16 mm Stainless steel screws for facades Vis de bardage avec rondelle d'étanchéité	KX160	222
	Fassadenbauschrauben mit Bohrspitze und Dichtscheibe Self drilling screws for facades with waterproof washer Vis de bardage autoperceuse avec rondelle d'étanchéité	-	-
	Spanplattenschrauben mit Linsensenkkopf und Kreuzschlitz Cross recessed raised countersunk (oval) head chipboard screws Vis à bois, tête fraisée bombée à empreinte cruciforme pour panneaux agglomérés - VBA	WN55	246
	Spanplattenschrauben mit Rundkopf und Kreuzschlitz Cross recessed pan head chipboard screws Vis à bois, tête ronde cruciforme pour panneaux agglomérés - VBA	WN56	247
	Spanplattenschrauben mit Senkkopf und Kreuzschlitz Cross recessed countersunk head chipboard screws Vis à bois, tête fraisée à empreinte cruciforme pour panneaux agglomérés - VBA	WN57	248 - 249
	Spanplattenschrauben mit Senkkopf und Innensechsrund Countersunk head chipboard screws with six lobe drive Vis à bois, tête fraisée TORX pour panneaux agglomérés - VBA	WN57	250 - 251



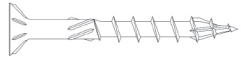
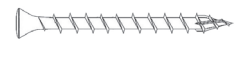
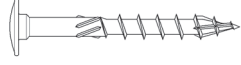
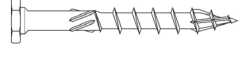
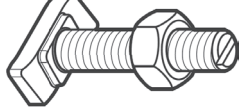

Abbildung	Bezeichnung	Norm	Seite
	Klemmhebel verstellbar Adjustable clamping lever Levier de serrage ajustable	WN440	-
	Schrauben für Kunststoff mit Flachkopf und Flansch (Kreuzschlitz) Cross recessed pan head screws with flange for plastics Vis autoformeuse pour plastique à tête bombée avec embase, empreinte cruciforme - PT	W1411	240
	Schrauben für Kunststoff mit Flachkopf (Kreuzschlitz) Cross recessed pan head screws for plastics Vis pour plastiques à tête bombée, empreinte cruciforme - PT	W1412	241
	Schrauben für Kunststoff mit Senkkopf (Kreuzschlitz) Cross recessed countersunk head screws for plastics Vis autoformeuse pour plastique à tête fraisée, empreinte cruciforme - PT	W1413	242
	Schrauben für Kunststoff mit Senkkopf und Innensechsrund Hexalobular countersunk head screws for plastics Vis autoformeuse pour plastique à tête fraisée, empreinte TORX - PT	W1423	245
	Schrauben für Kunststoff Flachkopf mit Flansch und Innensechsrund Hexalobular pan head screws with flange for plastics Vis autoformeuse pour plastique à tête bombée avec embase, emprunte TORX - PT	W1451	243
	Schrauben für Kunststoff mit Flachkopf und Innensechsrund Hexalobular pan head screws for plastics Vis autoformeuse pour plastique à tête bombée, empreinte TORX - PT	W1452	244

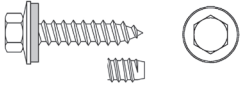
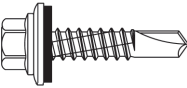
Abbildung	Bezeichnung	Norm	Seite
	Rhombus-Muttern für T-Nuten T-Nuts Rhombus Ecrous en té Rhombus	W2302	-
	Blindnietmuttern Blind rivets Rivets aveugles	VVG	-
	Hammerschlag-Blindnieten Blind drive pin rivets Rivets à frapper	VVG	-
	Blindnietgewindebolzen RIFBOLT Blind rivets threaded bolt - RIFBOLT Rivets - RIFBOLT	VVG	-
	Gewindeeinsätze selbstschneidend Threaded inserts self-tapping Douilles filetéés auto-taraudeuses	ENSAT 302	493
	Gewindeeinsätze selbstschneidend kurz Threaded inserts self-tapping Douilles filetéés auto-taraudeuses	ENSAT 307	494 - 495
	Gewindeeinsätze selbstschneidend lang Threaded inserts self-tapping Douilles filetéés auto-taraudeuses	ENSAT 308	496 - 497

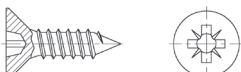
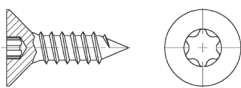





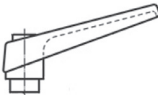
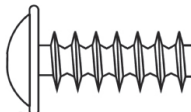
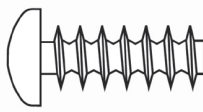
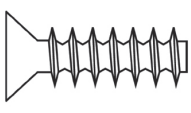
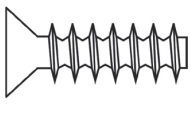
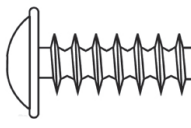
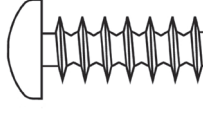

Abbildung	Bezeichnung	Norm	Seite
	Gewindeeinsätze MUBUX Inserts - MUBUX Inserts - MUBUX	WN850 WN852	-
	Einpress-Gewinde-Stift CLIFA Press-in studs - CLIFA Inserts filetés - CLIFA	CLIFA	-
	FISCHER Befestigungstechnik Fixing systems FISCHER Système de fixation de la marque FISCHER		separater Katalog
	UPAT Schwerlast-Befestigungen-Chemie Anchors program UPAT Système de fixation de la gamme UPAT		separater Katalog
	MKT Befestigungstechnik MKT Heavy duty - light duty - chemical anchors Système de fixation de la marque MKT		separater Katalog
	HALDER Normalien / Normteile nach DIN und Werksnorm Program HALDER Gamme HALDER		separater Katalog
	HECO Schrauben Screws HECO Gamme visserie HECO		separater Katalog

Abbildung	Bezeichnung	Norm	Seite
	KERB KONUS Gewindeeinsätze Program KERB KONUS Programme d'inserts KERB KONUS		separater Katalog
	LINDAPTER Stahlträger-Klemmsysteme Steel connections program LINDAPTER Programme des systèmes de fixation pour charpentes métalliques LINDAPTER		separater Katalog
	LOCTITE Industrielle Hochleistungs-Kleb- und Dichtstoffe High performance industrial adhesives and sealants LOCTITE Gamme complète de LOCTITE		separater Katalog
	NORDWEST chemische Produkte Chemical products NORDWEST Produits chimique NORDWEST		separater Katalog
 VVG Befestigungstechnik <small>Ein Unternehmen der HONSEL-Gruppe</small>	VVG Niettechnik VVG program Gamme complète de VVG		separater Katalog



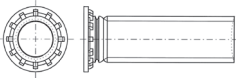

Zur Bestellung einer Schraube benötigen Sie folgende Angaben:

- 1.** Norm
- 2.** Bezeichnung
- 3.** Güte / Werkstoff
- 4.** Gewindedurchmesser
- 5.** Länge
- 6.** Verpackungseinheit

Beispiel:

DIN 915 Gewindestifte mit Innensechskant und Zapfen - 45H - M6 x 16 - 200 Stück

Diese Informationen bitte per Telefon, Fax oder E-Mail an Schrauben Jäger senden. Im Online-Shop www.schrauben-jaeger.de geht die Bestellung noch schneller.

2.

Gewindestifte
mit Innensechskant und Zapfen

1.

DIN 915

VPE	M3	M4	M5	M6	M8	M10	M12	M16	M20	M24
3	1000	-	-	-	-	-	-	-	-	-
4	1000	1000	1000	-	-	-	-	-	-	-
5	1000	1000	1000	500	-	-	-	-	-	-
6	1000	1000	1000	500	200	-	-	-	-	-
8	1000	1000	1000	500	200	-	-	-	-	-
10	1000	1000	1000	500	200	200	100	-	-	-
12	1000	1000	1000	500	200	200	100	-	-	-
14	1000	1000	1000	500	200	100	-	-	-	-
16	1000	1000	500	500	200	100	50	-	-	-
20	1000	500	500	200	100	100	50	25	-	-
25	1000	500	500	200	200	100	100	50	25	-
30	1000	500	500	200	200	100	100	50	25	25
35	-	500	500	200	200	100	100	50	25	25
40	-	500	500	200	200	100	100	25	25	25
45	-	-	500	200	200	100	100	25	25	25
50	-	-	200	200	200	100	100	25	25	25
55	-	-	-	200	200	100	100	25	25	-
60	-	-	-	200	200	100	100	25	25	25
70	-	-	-	200	200	100	50	25	25	25
80	-	-	-	-	200	100	50	25	25	25
90	-	-	-	-	-	100	50	25	25	25
100	-	-	-	-	-	-	50	25	25	25

Die handelsüblichen Größen sind durch Angabe der VPE gekennzeichnet.
Lieferbar in Güte: 45H sowie Elektrolyt A2 und Edelstahl A4



Wenn Sie andere Artikel bestellen, notieren Sie bitte alle Angaben vom Seitenkopf (**1.**, **2.**) und die vollständige Bemaßung aus der Tabellenzeile. Und eventuell die gewünschte Oberfläche.





Maße in mm

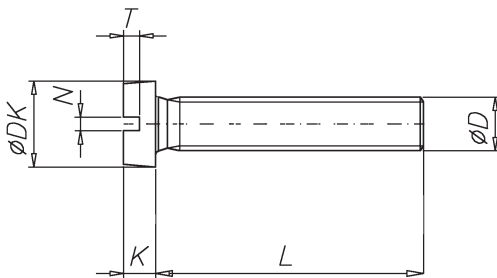

D	M2	M2,5	M3	M3,5	M4	M5	M6	M8	M10
P ¹⁾	0,4	0,45	0,5	0,6	0,7	0,8	1	1,25	1,5
DK	3,8	4,5	5,5	6	7	8,5	10	13	16
K	1,3	1,6	2	2,4	2,6	3,3	3,9	5	6
N	0,5	0,6	0,8	1	1,2	1,2	1,6	2	2,5
T min	0,6	0,7	0,85	1	1,1	1,3	1,6	2	2,4

¹⁾ Gewindesteigung

VPE

L \ D	M2	M2,5	M3	M3,5	M4	M5	M6	M8	M10
3	1000	1000	1000	–	–	–	–	–	–
4	1000	1000	1000	–	500	–	–	–	–
5	1000	1000	1000	1000	500	500	–	–	–
6	1000	1000	1000	1000	500	500	200	–	–
8	1000	1000	1000	1000	500	500	200	–	–
10	1000	1000	1000	1000	500	500	200	200	–
12	1000	1000	1000	1000	500	200	200	200	–
14	1000	1000	1000	–	500	200	200	–	–
16	1000	1000	1000	1000	500	200	200	200	100
18	1000	1000	1000	–	500	200	200	–	–
20	1000	1000	1000	1000	500	200	200	200	100
22	–	1000	1000	–	500	200	–	–	–
25	1000	1000	1000	1000	500	200	200	200	100
30	1000	1000	1000	1000	500	200	200	200	100
35	–	–	1000	1000	500	200	500	200	100
40	–	–	1000	1000	500	200	200	200	100
45	–	–	1000	–	500	200	200	200	100
50	–	–	1000	500	500	200	200	200	100
55	–	–	500	–	500	200	200	200	100
60	–	–	500	500	500	200	200	100	100
65	–	–	–	–	200	200	200	–	–
70	–	–	–	–	200	200	200	100	100
75	–	–	–	–	200	200	200	–	–
80	–	–	–	–	200	200	200	100	100
90	–	–	–	–	200	200	200	100	100
100	–	–	–	–	200	200	200	100	100

Die handelsüblichen Größen sind durch Angabe der VPE gekennzeichnet.

Lieferbar in Güte: 4.8, Messing, Polyamid sowie Edelstahl A2 und Edelstahl A4

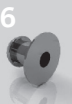



Maße in mm

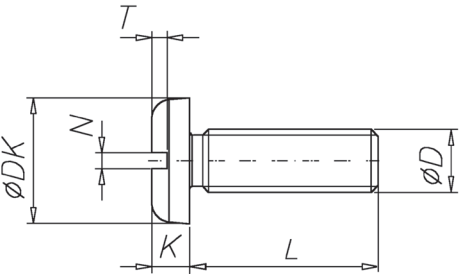

D	M2,5	M3	M3,5	M4	M5	M6	M8
P ¹⁾	0,45	0,5	0,6	0,7	0,8	1	1,25
DK	5	6	7	8	10	12	16
K	1,5	1,8	2,1	2,4	3	3,6	4,8
N	0,6	0,8	1	1,2	1,2	1,6	2
T min	0,6	0,7	0,8	1	1,2	1,4	1,9

¹⁾ Gewindesteigung

VPE

L \ D	M2,5	M3	M3,5	M4	M5	M6	M8
4	–	200	–	–	–	–	–
5	–	200	200	200	–	–	–
6	200	200	200	200	200	–	–
8	200	200	200	200	200	200	–
10	200	200	200	200	200	200	100
12	200	200	200	200	200	200	100
14	–	200	–	200	200	200	–
16	200	200	200	200	200	200	100
18	–	200	–	200	200	200	–
20	–	200	200	200	200	200	100
25	–	200	200	200	200	200	100
30	–	200	200	200	200	200	100
35	–	200	–	200	200	200	100
40	–	200	–	200	200	200	100
45	–	200	–	200	200	200	100
50	–	200	–	200	200	200	100
60	–	–	–	200	200	200	100
70	–	–	–	200	200	100	–
80	–	–	–	–	200	100	–
100	–	–	–	–	–	100	–

Die handelsüblichen Größen sind durch Angabe der VPE gekennzeichnet.

Lieferbar in Güte: 4.8, Messing, Polyamid sowie Edelstahl A2 und Edelstahl A4

1



2



3



4



5



6



7



8



9





Maße in mm

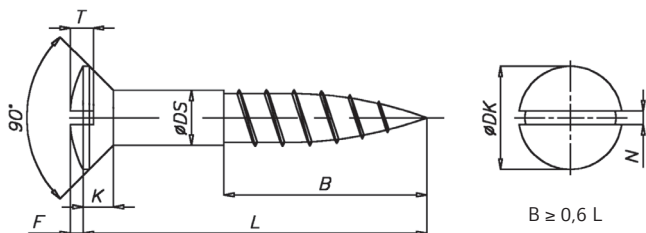

D	2,5	3	3,5	4	4,5	5	6
DS	2,5	3	3,5	4	4,5	5	6
DK	4,7	5,6	6,5	7,5	8,3	9,2	11
K	1,5	1,65	1,93	2,2	2,35	2,5	3
N	0,6	0,8	0,8	1	1	1,2	1,6
T max	1,2	1,45	1,7	1,9	2,1	2,3	2,8
F	0,6	0,75	0,9	1	1,1	1,25	1,5

Auch mit Kreuzschlitz nach DIN 7995 lieferbar.

VPE

L \ D	2,5	3	3,5	4	4,5	5	6
10	200	-	-	-	-	-	-
12	200	200	200	-	-	-	-
16	200	200	200	200	200	-	-
20	200	200	200	200	200	200	-
25	-	200	200	200	200	200	-
30	-	200	200	200	200	200	100
35	-	200	200	200	200	200	100
40	-	200	200	200	200	200	100
45	-	-	-	200	200	200	100
50	-	-	-	200	200	200	100
60	-	-	-	200	200	100	100
70	-	-	-	-	200	100	100
80	-	-	-	-	200	100	100
90	-	-	-	-	-	100	100
100	-	-	-	-	-	100	100

Die handelsüblichen Größen sind durch Angabe der VPE gekennzeichnet.
Lieferbar in Stahl, Messing sowie Edelstahl A2

Maße in mm

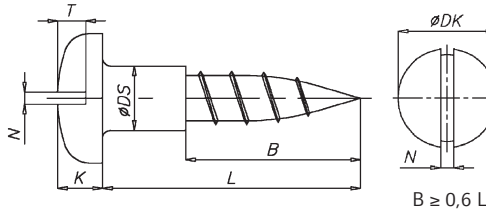

D	2	2,5	3	3,5	4	4,5	5	6
DS	2	2,5	3	3,5	4	4,5	5	6
DK	4	5	6	7	8	9	10	12
K	1,4	1,7	2,1	2,4	2,8	3,1	3,5	4,2
N	0,5	0,6	0,8	0,8	1	1	1,2	1,6
T max	0,9	1,1	1,35	1,6	1,8	2	2,3	2,7

Auch mit Kreuzschlitz nach DIN 7996 lieferbar.

VPE

L \ D	2	2,5	3	3,5	4	4,5	5	6
8	500	–	–	–	–	–	–	–
10	500	500	200	200	200	–	–	–
12	500	500	200	200	200	–	–	–
16	500	500	200	200	200	–	200	–
20	500	500	200	200	200	200	200	200
25	–	500	200	200	200	200	200	200
30	–	500	200	200	200	200	200	200
35	–	–	200	200	200	200	200	200
40	–	–	200	200	200	200	200	200
45	–	–	200	200	200	200	200	200
50	–	–	200	200	200	200	200	200
60	–	–	–	200	200	200	200	200
70	–	–	–	200	200	200	200	100
80	–	–	–	200	200	200	200	100
90	–	–	–	–	200	–	200	100
100	–	–	–	–	200	–	200	100
120	–	–	–	–	–	–	200	100

Die handelsüblichen Größen sind durch Angabe der VPE gekennzeichnet.
Lieferbar in Stahl, Messing sowie Edelstahl A2





Maße in mm

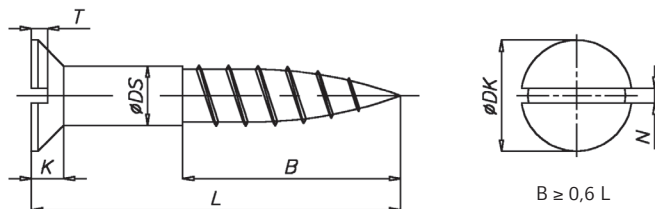

D	3	3,5	4	4,5	5	6	8
DS	3	3,5	4	4,5	5	6	8
DK	5,6	6,5	7,5	8,3	9,2	11	14,5
K	1,65	1,93	2,2	2,35	2,5	3	4
N	0,8	0,8	1	1	1,2	1,6	2
T max	0,85	1	1,1	1,2	1,3	1,6	2,1

Auch mit Kreuzschlitz nach DIN 7997 lieferbar.

VPE

L \ D	3	3,5	4	4,5	5	6	8
8	200	–	–	–	–	–	–
10	200	200	–	–	–	–	–
12	200	200	200	–	–	–	–
16	200	200	200	200	–	–	–
20	200	200	200	200	200	–	–
25	200	200	200	200	200	200	–
30	200	200	200	200	200	200	–
35	200	200	200	200	200	200	–
40	200	200	200	200	200	200	100
45	200	200	200	200	200	200	–
50	200	200	200	200	200	200	100
60	–	–	200	200	200	100	100
70	–	–	200	200	200	100	100
80	–	–	200	200	200	100	100
90	–	–	200	200	200	100	100
100	–	–	–	200	200	100	100
120	–	–	–	–	–	100	100

Die handelsüblichen Größen sind durch Angabe der VPE gekennzeichnet.
Lieferbar in Stahl, Messing sowie Edelstahl A2

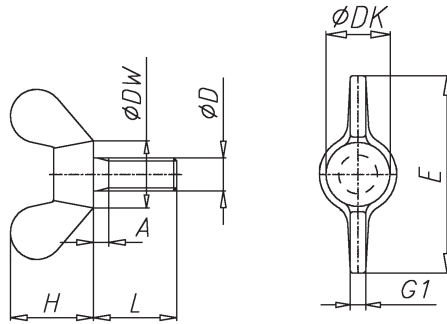

Maße in mm

D	M4	M5	M6	M8	M10	M12
P ¹⁾	0,7	0,8	1	1,25	1,5	1,75
A max	2,1	2,4	3	4	4,5	5,3
DW max	8	11	13	16	20	23
DK max	7	9	11	12,5	16,5	19,5
E max	20	26	33	39	51	65
H max	10,5	13	17	20	25	33,5
G1 max	1,9	2,3	2,3	2,8	4,4	4,9

¹⁾ Gewindesteigung

VPE

L \ D	M4	M5	M6	M8	M10	M12
8	200	–	–	–	–	–
10	200	200	100	50	–	–
12	200	200	100	50	–	–
16	200	200	100	50	50	–
20	200	200	100	50	50	50
25	200	200	100	50	50	50
30	200	100	100	50	50	50
35	–	100	100	50	50	50
40	200	100	100	50	50	50
50	–	–	100	50	50	50
60	–	–	100	50	50	20

Die handelsüblichen Größen sind durch Angabe der VPE gekennzeichnet.
Lieferbar in Temperguss, Messing sowie NIRO



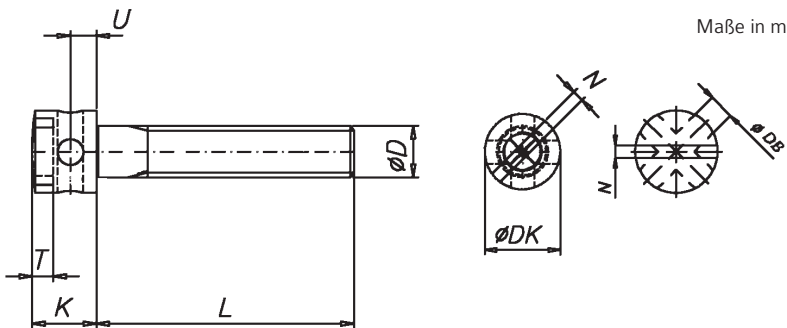

D	M3	M4	M5	M6	M8
P ¹⁾	0,5	0,7	0,8	1	1,25
DK	5,5	7	8,5	10	13
K	4	5	6,5	8	10
DB	1,5	2	2,5	3	4
N	0,8	1	1,2	1,6	2
T min	1	1,4	1,7	2,2	2,7
U	1,5	2	2,5	3	4

¹⁾ Gewindesteigung

VPE

L \ D	M3	M4	M5	M6	M8
4	100	–	–	–	–
6	100	100	–	–	–
8	100	100	–	–	–
10	100	100	100	–	–
12	100	100	100	100	100
16	100	100	100	100	100
20	100	100	100	100	100
25	100	100	100	100	100
30	–	–	100	100	100
40	–	–	–	100	100

Die handelsüblichen Größen sind durch Angabe der VPE gekennzeichnet.
Lieferbar in Güte: 5.8

Maße in mm

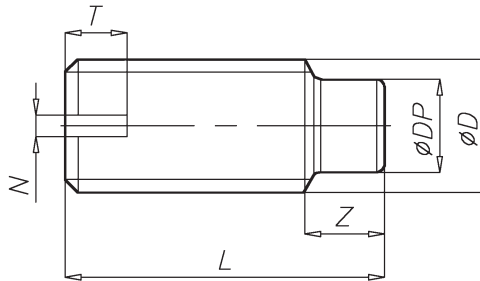

D	M3	M4	M5	M6	M8
P ¹⁾	0,5	0,7	0,8	1	1,25
DP	2	2,5	3,5	4	5,5
N	0,4	0,6	0,8	1	1,2
T	0,8	1,12	1,28	1,6	2
Z	1,5	2	2,5	3	4

¹⁾ Gewindesteigung

VPE

L \ D	M3	M4	M5	M6	M8
5	200	–	–	–	–
6	200	200	100	–	–
8	200	200	100	100	–
10	200	200	100	100	100
12	200	200	100	100	100
16	200	200	100	100	100
20	200	200	100	100	100
25	–	100	–	100	100
30	–	100	100	100	100
35	–	–	–	–	100
40	–	–	–	100	100
45	–	–	–	–	100
50	–	–	–	–	100

Die handelsüblichen Größen sind durch Angabe der VPE gekennzeichnet.





Maße in mm

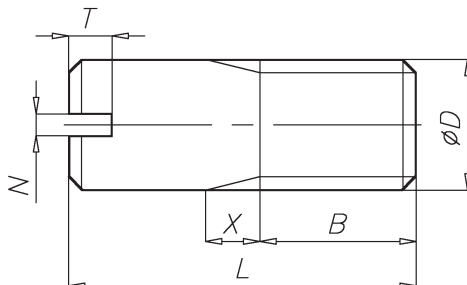

D	M2	M3	M4	M5	M6	M8	M10	M12
P ¹⁾	0,4	0,5	0,7	0,8	1	1,25	1,5	1,75
B	2,4	3,6	4,8	6	7,2	9,6	12	14
N	0,25	0,4	0,6	0,8	1	1,2	1,6	2
T	0,84	1,05	1,42	1,63	2	2,5	3	3,7
X	1	1,25	1,75	2	2,5	3,2	3,8	4,3

¹⁾ Gewindesteigung

VPE

L \ D	M2	M3	M4	M5	M6	M8	M10	M12
5	100	-	-	-	-	-	-	-
6	-	100	-	-	-	-	-	-
8	100	100	100	100	-	-	-	-
10	100	100	100	100	100	-	-	-
12	-	100	100	100	100	100	-	-
16	-	100	100	100	100	100	-	-
20	-	100	100	100	100	100	100	-
25	-	-	100	100	100	100	100	-
30	-	-	-	100	100	100	100	100
35	-	-	-	-	100	100	100	100
40	-	-	-	100	100	100	100	100
45	-	-	-	-	-	100	100	100
50	-	-	-	-	100	100	100	100
60	-	-	-	-	-	100	100	50

Die handelsüblichen Größen sind durch Angabe der VPE gekennzeichnet.
Lieferbar in Güte: 5.8

Maße in mm

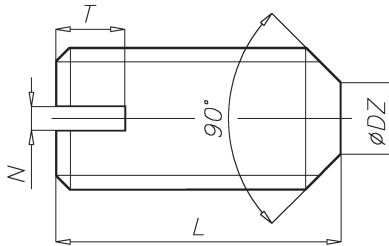

D	M3	M4	M5	M6	M8	M10
P ¹⁾	0,5	0,7	0,8	1	1,25	1,5
DZ	1,4	2	2,5	3	5	6
N	0,6	0,8	1	1,2	1,51	1,91
T	1,05	1,42	1,63	2	2,5	3

¹⁾ Gewindesteigung

VPE

L \ D	M3	M4	M5	M6	M8	M10
4	100	100	–	–	–	–
5	100	100	100	–	–	–
6	100	100	100	100	–	–
8	100	100	100	100	100	–
10	100	100	100	100	100	100
12	100	100	100	100	100	100
16	–	100	100	100	100	100
20	–	100	100	100	100	100
25	–	–	–	100	100	100
30	–	–	–	–	100	100

Die handelsüblichen Größen sind durch Angabe der VPE gekennzeichnet.
Lieferbar in Güte: 5.8



Maße in mm

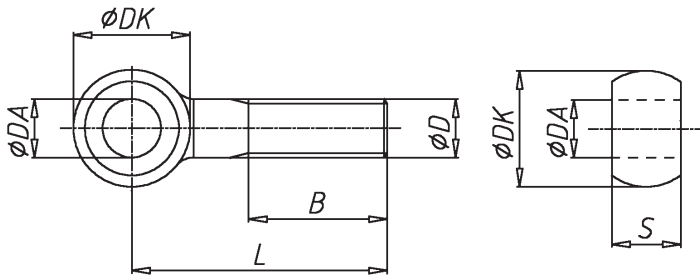

D	M6	M8	M10	M12	M16	M20	M24	M30	M36
P ¹⁾	1	1,25	1,5	1,75	2	2,5	3	3,5	4
B ²⁾	18	22	26	30	38	46	54	66	-
B ³⁾	-	28	32	36	44	52	60	72	84
B ⁴⁾	-	-	-	49	57	65	73	85	97
DA ^(H9)	6	8	10	12	16	18	22	28	33
DK max	14	18	20	25	32	40	45	55	65
S max	7	9	12	14	17	22	25	30	38

Augenschrauben können auch mit Gewinde annähernd bis Auge geliefert werden. In diesem Fall ist der Buchstabe L in die Bezeichnung einzufügen.

Auch in Form A (grob) und C (mittel) lieferbar.

¹⁾ Gewindesteigung

²⁾ B für L <= 125

³⁾ B für 125 < L <= 200

⁴⁾ B für L > 200

VPE

L \ D	M6	M8	M10	M12	M16	M20
20	100	100	–	–	–	–
25	100	100	100	–	–	–
30	100	100	100	100	–	–
35	100	100	100	100	–	–
40	100	100	100	100	25	–
45	100	100	100	100	25	–
50	100	100	100	50	25	–
55	100	100	100	50	25	–
60	100	100	100	50	25	–
65	100	100	100	50	25	–
70	100	100	100	50	25	–
80	100	100	50	50	25	–
90	–	100	50	50	25	–
100	–	100	50	50	25	25
110	–	100	50	50	25	25
120	–	100	50	50	25	25
130	–	–	50	50	25	25
140	–	–	50	50	25	25
150	–	–	50	50	25	25
160	–	–	–	50	25	25
180	–	–	–	–	25	25
200	–	–	–	–	25	25

Die handelsüblichen Größen sind durch Angabe der VPE gekennzeichnet.
 Lieferbar in Güte: 4.6 sowie Edelstahl A2-50 und A4-50





Maße in mm

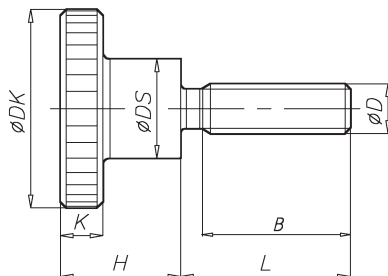

D	M3	M4	M5	M6	M8	M10
P ¹⁾	0,5	0,7	0,8	1	1,25	1,5
B	9	12	15	18	24	30
DK	12	16	20	24	30	36
DS	6	8	10	12	16	20
K	2,5	3,5	4	5	6	8
H	7,5	9,5	11,5	15	18	23

¹⁾ Gewindesteigung

VPE

L \ D	M3	M4	M5	M6	M8	M10
6	100	100	–	–	–	–
8	100	100	100	50	–	–
10	100	100	100	50	50	–
12	100	100	100	50	50	–
16	100	100	100	50	50	–
20	100	100	100	50	50	50
25	100	100	100	50	50	50
30	–	100	100	50	50	50
40	–	100	100	50	50	50
50	–	–	–	–	50	50

Die handelsüblichen Größen sind durch Angabe der VPE gekennzeichnet.

Lieferbar in Güte: 5.8 und Messing

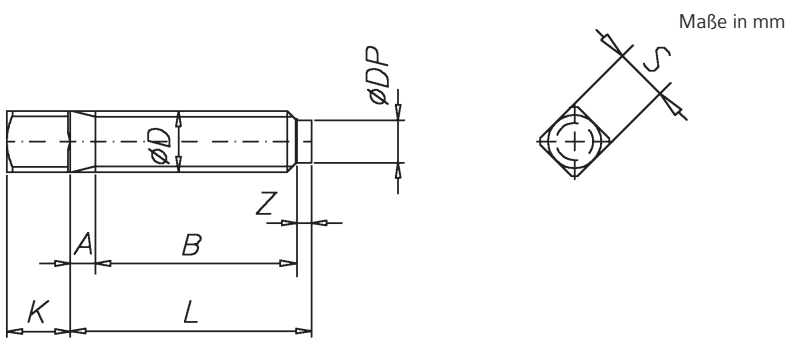

D	M6	M8	M10	M12	M16	M20
P ¹⁾	1	1,25	1,5	1,75	2	2,5
A	3	4	4,5	5,3	6	7,5
DP	4	5,5	7	8,5	12	15
K	6	8	10	12	16	20
S	6	8	10	13	16 / 17	21 / 22
Z	1,5	2	2,5	3	4	5

¹⁾ Gewindesteigung

VPE

L \ D	M6	M8	M10	M12	M16	M20
10	100	–	–	–	–	–
12	100	–	–	–	–	–
16	100	100	100	–	–	–
20	100	100	100	–	–	–
25	100	100	100	–	–	–
30	100	100	100	50	–	–
35	100	100	100	50	–	–
40	100	100	100	50	25	–
45	–	100	100	50	25	–
50	–	100	100	50	25	25
60	–	–	100	50	25	25
70	–	–	–	50	50	25
80	–	–	–	50	25	25
90	–	–	–	50	25	25
100	–	–	–	50	25	25

Die handelsüblichen Größen sind durch Angabe der VPE gekennzeichnet.
Lieferbar in Güte: 8.8



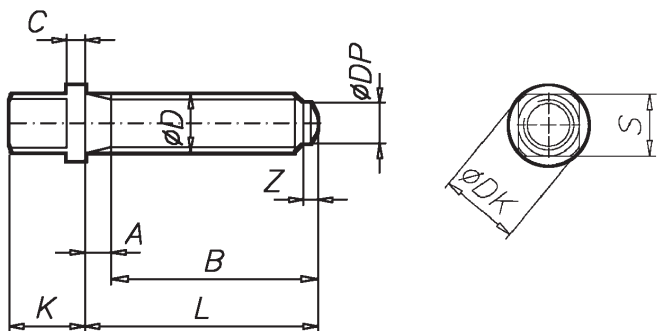

Maße in mm

D	M8	M10	M12	M16	M20	M24
P ¹⁾	1,25	1,5	1,75	2	2,5	3
A	4	4,5	5,3	6	7,5	9
C	3,12	3,12	4,15	4,15	5,15	6,15
DP	5,5	7	8,5	12	15	18
K	11	13	16	20	25	28
Z min	2	2,5	3	4	5	6
S	8	10	13	17	22	24
DK	10	13	17	22	28	32

¹⁾ Gewindesteigung

VPE

L \ D	M8	M10	M12	M16	M20	M24
20	100	–	–	–	–	–
30	100	100	–	–	–	–
35	100	100	–	–	–	–
40	100	100	100	–	–	–
50	–	100	50	25	–	–
60	–	100	50	25	25	25
70	–	–	50	25	25	25
80	–	–	25	25	25	25
100	–	–	–	–	25	25

Die handelsüblichen Größen sind durch Angabe der VPE gekennzeichnet.
Lieferbar in Güte: 10.9

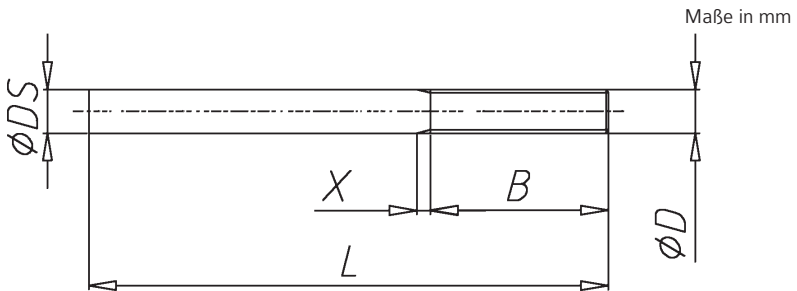

D	M8	M10	M12	M16	M20	M24
P ¹⁾	1,25	1,5	1,75	2	2,5	3
B	40	45	55	65	75	85
DS	8	10	12	16	20	24
L	140	150	170	190	210	230
X	3,2	3,8	4,3	5	6,3	7,5

Anschweißenden werden mit Dünnschaft geliefert. Gewinde gerollt.

¹⁾ Gewindesteigung

VPE

M8	M10	M12	M16	M20	M24
50	50	25	25	10	10

Die handelsüblichen Größen sind durch Angabe der VPE gekennzeichnet.
Lieferbar in Stahl



1



2



3



4



5



6



7



8



9

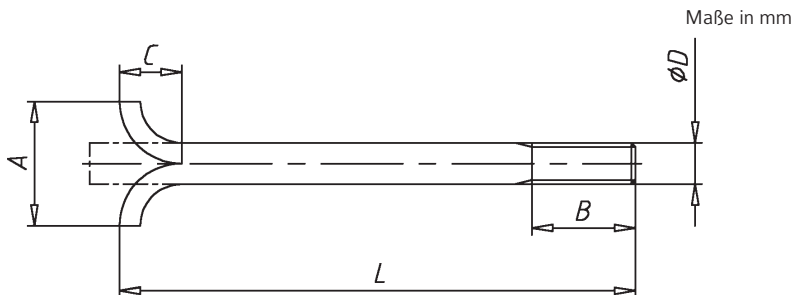

D	M8	M10	M12	M16	M20
P ¹⁾	1,25	1,5	1,75	2	2,5
B	20	25	30	40	50
A	24	30	36	48	60
C	12	15	18	24	30

Weitere Formen lieferbar.

¹⁾ Gewindesteigung

VPE

L \ D	M8	M10	M12	M16	M20
80	100	–	–	–	–
90	100	–	–	–	–
100	100	50	50	–	–
120	100	50	50	–	–
150	–	50	50	25	–
160	–	50	25	25	10
180	–	50	25	25	10
200	–	50	25	25	10
220	–	–	25	25	10
250	–	–	25	25	10
300	–	–	25	25	10
350	–	–	–	25	10
400	–	–	–	25	10
450	–	–	–	10	10
500	–	–	–	–	10

Die handelsüblichen Größen sind durch Angabe der VPE gekennzeichnet.

Lieferbar in Güte: 3.6

Maße in mm

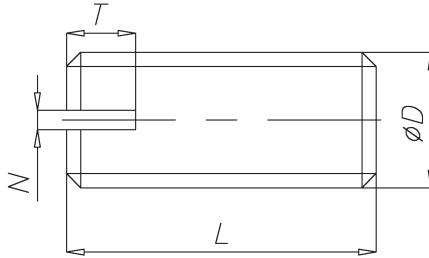

D	M2	M2,5	M3	M4	M5	M6	M8	M10	M12	M16
P ¹⁾	0,4	0,45	0,5	0,7	0,8	1	1,25	1,5	1,75	2
N	0,25	0,4	0,4	0,6	0,8	1	1,2	1,6	2	2,8
T	1,2	1,33	1,5	2,05	2,35	2,9	3,6	4,25	5	6,4

¹⁾ Gewindesteigung

VPE

L \ D	M2	M2,5	M3	M4	M5	M6	M8	M10	M12
3	200	200	200	200	–	–	–	–	–
4	200	200	200	200	100	–	–	–	–
5	200	200	200	200	100	100	–	–	–
6	200	200	200	200	100	100	100	100	–
8	200	200	200	200	100	100	100	100	–
10	200	200	200	200	100	100	100	100	100
12	–	–	200	200	100	100	100	100	100
16	200	200	200	200	100	100	100	100	100
20	–	–	200	200	100	100	100	100	100
25	–	–	200	200	100	100	100	100	100
30	–	–	200	200	100	100	100	100	100
35	–	–	–	200	100	100	100	100	100
40	–	–	–	200	100	100	100	100	100
45	–	–	–	–	100	100	100	100	100
50	–	–	–	–	100	100	100	100	100
60	–	–	–	–	–	–	100	100	100

Die handelsüblichen Größen sind durch Angabe der VPE gekennzeichnet.
Lieferbar in Güte: 14H sowie Edelstahl A1-50





Maße in mm

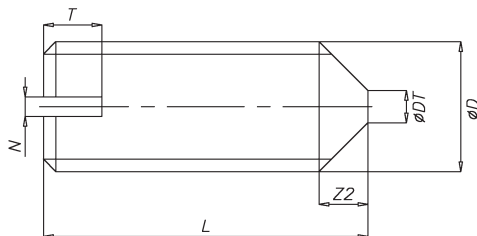

D	M2	M2,5	M3	M4	M5	M6	M8	M10	M12
P ¹⁾	0,4	0,45	0,5	0,7	0,8	1	1,25	1,5	1,75
N	0,25	0,4	0,4	0,6	0,8	1	1,2	1,6	2
T	1,2	1,33	1,5	2,05	2,35	2,9	3,6	4,25	5
Z2	1	1,25	1,5	2	2,5	2,5	3	4	5
DT max	0,2	0,25	0,3	0,4	0,5	1,5	2	2,5	3

¹⁾ Gewindesteigung

VPE

L \ D	M2	M2,5	M3	M4	M5	M6	M8	M10	M12
3	200	200	200	–	–	–	–	–	–
4	200	200	200	200	100	–	–	–	–
5	200	200	200	200	100	100	–	–	–
6	200	200	200	200	100	100	–	–	–
8	200	200	200	200	100	100	100	–	–
10	200	200	200	200	100	100	100	100	–
12	200	200	200	200	100	100	100	100	–
16	–	–	200	200	100	100	100	100	100
20	–	–	200	200	100	100	100	100	100
25	–	–	–	200	100	100	100	100	100
30	–	–	–	200	100	100	100	100	100
35	–	–	–	–	–	100	100	100	100
40	–	–	–	–	–	100	100	100	100
45	–	–	–	–	–	100	100	100	100
50	–	–	–	–	–	–	100	100	100
60	–	–	–	–	–	–	100	100	100

Die handelsüblichen Größen sind durch Angabe der VPE gekennzeichnet.

Lieferbar in Güte: 14H sowie Edelstahl A1-50

Maße in mm

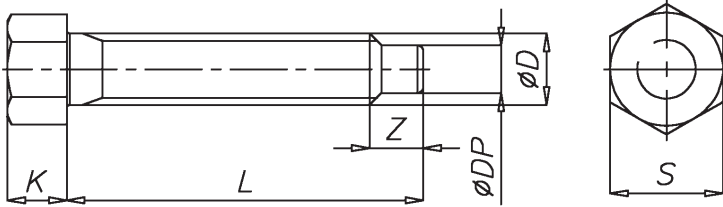

D	M6	M8	M10	M12	M16	M20	M24	M30
P ¹⁾	1	1,25	1,5	1,75	2	2,5	3	3,5
DP	4	5,5	7	8,5	12	15	18	23
K	5	6	7	6,2	11	14	17	21
S	8	10	13	16	19	24	30	36
Z	3	4	5	6	8	10	12	15

Gewindeauslauf (DP und Z) nach DIN 78.

Diese Schrauben können auch mit Gewindefreistich (RI) nach DIN 962 geliefert werden.

¹⁾ Gewindesteigung

VPE

L \ D	M6	M8	M10	M12	M16	M20	M24	M30
12	100	–	–	–	–	–	–	–
16	100	100	100	–	–	–	–	–
20	100	100	100	–	–	–	–	–
25	100	100	100	100	–	–	–	–
30	100	100	100	100	50	–	–	–
35	100	100	100	100	50	–	–	–
40	100	100	100	100	50	–	–	–
45	100	100	100	100	50	–	–	–
50	100	100	100	100	50	50	–	–
60	–	100	100	100	50	50	25	25
70	–	100	100	100	50	50	25	25
80	–	100	100	100	50	50	25	25
90	–	–	–	100	50	50	25	25
100	–	–	–	–	50	50	25	25
120	–	–	–	–	–	–	25	25
140	–	–	–	–	–	–	–	25

Die handelsüblichen Größen sind durch Angabe der VPE gekennzeichnet.
Lieferbar in Güte: 8.8



Maße in mm

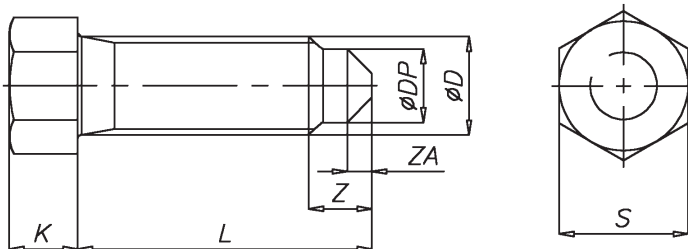

D	M6	M8	M10	M12	M16	M20
P ¹⁾	1	1,25	1,5	1,75	2	2,5
DP	4	5,5	7	8,5	12	15
K	5	6	7	9	11	14
S	8	10	13	16	18	24
Z	3	4	5	6	8	10
ZA	1,7	2,5	3	3,5	4,5	5

Gewindeauslauf DP, ZA und Z nach DIN 78.

Diese Schrauben können auch mit Gewindefreistich (RI) nach DIN 962 geliefert werden.

¹⁾ Gewindesteigung

VPE

L \ D	M6	M8	M10	M12	M16	M20
12	100	–	–	–	–	–
16	100	100	–	–	–	–
20	100	100	100	–	–	–
25	100	100	100	100	–	–
30	100	100	100	100	50	–
35	100	100	100	100	50	–
40	100	100	100	100	50	50
45	–	–	100	100	50	50
50	–	100	100	100	50	50
60	–	–	–	100	50	50
70	–	–	–	100	50	50
80	–	–	–	–	50	50
90	–	–	–	–	50	50
100	–	–	–	–	–	50

Die handelsüblichen Größen sind durch Angabe der VPE gekennzeichnet.
Lieferbar in Güte: 8.8



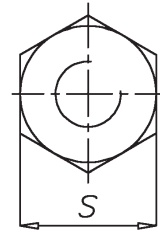
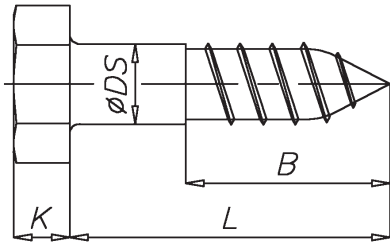

Maße in mm

$$B \geq 0,6 L$$

DS	5	6	8	10	12	16	20
K	3,5	4	5,5	7	8	10	13
S	8	10	13	17	19	24	30

VPE

L \ DS	5	6	8	10	12	16
20	500	200	–	–	–	–
25	500	200	200	–	–	–
30	200	200	200	100	–	–
35	200	200	200	100	–	–
40	200	200	200	100	100	–
45	200	200	200	100	100	25
50	200	200	200	100	100	25
60	200	200	200	100	100	25
70	–	200	200	100	50	25
80	–	200	200	100	50	25
90	–	200	100	100	50	25
100	–	200	100	100	50	25
110	–	100	100	50	50	25
120	–	100	100	50	50	25
130	–	–	100	50	50	25
140	–	100	50	50	50	25
150	–	100	50	50	50	25
160	–	–	50	50	25	25
180	–	–	50	50	25	25
200	–	–	50	50	25	25
220	–	–	50	50	25	25
240	–	–	50	50	25	25
260	–	–	–	50	25	25
280	–	–	–	50	25	25
300	–	–	–	50	25	25
340	–	–	–	50	25	–
360	–	–	–	–	25	–
380	–	–	–	–	25	–
400	–	–	–	–	25	–

Die handelsüblichen Größen sind durch Angabe der VPE gekennzeichnet.
Lieferbar in Stahl sowie Edelstahl A2





Maße in mm

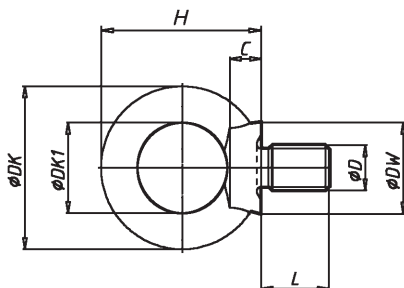

D	M8	M10	M12	M16	M20	M24	M30	M36	M42	M48
DW	20	25	30	35	40	50	65	75	85	100
DK	36	45	54	63	72	90	108	126	144	166
DK1	20	25	30	35	40	50	60	70	80	90
C	6	8	10	12	14	18	22	26	30	35
H	36	45	53	62	71	90	109	128	147	168
K	8	10	12	14	16	20	24	28	32	38
L	13	17	20,5	27	30	36	45	54	63	68

Normumstellung DIN 580: Die DIN 580 Ausgabe 1972-03 in Werkstoff C15 wurde durch die DIN 580 Ausgabe 2003-08 in Werkstoff C15E abgelöst. Aufgrund der großen Nachfrage führen wir weiterhin Ringschrauben nach der alten DIN 580 (1972-03) in Werkstoff: C15. Diese dürfen aber nicht für sicherheitsrelevante Anwendungen verwendet werden. Dies gilt insbesondere im Bereich der Lastaufnahme. Bitte verwenden sie in diesem Fall Ringschrauben nach der neuen Norm in Werkstoff C15E.

VPE

M8	M10	M12	M16	M20	M24	M30	M36	M42	M48
50	50	25	25	10	5	5	5	1	1

Die handelsüblichen Größen sind durch Angabe der VPE gekennzeichnet.
Lieferbar in Güte: C15, C15E sowie Edelstahl A2 und Edelstahl A4

Traglastentabelle für Ringschrauben

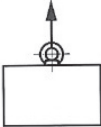
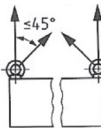
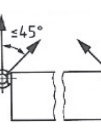
Gewinde (D)	M8	M10	M12	M16	M20	M24	M30	M36	M42
 Tragfähigkeit axial je Ringschraube kg	140	230	340	700	1200	1800	3200	4600	6300
 Tragfähigkeit je Ringschraube ≤ 45° kg	100	170	240	500	860	1290	2300	3300	4500
 Tragfähigkeit seitlich je Ringschraube ≤ 45° kg	70	115	170	350	600	900	1600	2300	3150

Ringschrauben nach dieser Norm dienen vornehmlich als Lastaufnahmemittel zur dauerhaften Befestigung an Bauteilen zu deren Transport. Für die wechselnde Benutzung an verschiedenen zu transportierenden Gegenständen, wie z.B. Großwerkzeugen, müssen Ringschrauben mit dem nächstgrößeren Gewindedurchmesser verwendet werden. Bei Anwendung mit mehrsträngigen Anschlagmitteln sind die Regeln z.B. nach DIN 818-4 zu beachten.

Die Tragfähigkeitsangaben aus der Tabelle gelten nur, wenn:

- die Ringschraube bei ausreichender Gewindetiefe vollständig eingedreht ist.
- die Ringschraube eben und vollflächig auf der Auflagefläche aufliegt.
- die eingeleiteten Kräfte vom Grundwerkstoff ohne die Sicherheit beeinträchtigende Verformungen aufgenommen werden können.
- die Sacklöcher so tief gebohrt sind, dass die Auflagefläche aufliegen kann.

Benutzerinformation:

1. Die in der zweiten Zeile der Tabelle angegebene Tragfähigkeit gilt bis max. 45° Neigungswinkel, die in der dritten Zeile angegebene Tragfähigkeit bei seitlich eingeschraubten Ringschrauben bis max. 45° Neigungswinkel in Richtung der Ringebene. Seitenzug sollte nicht angewendet werden.

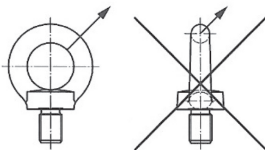

2. Bei Durchgangslöchern sollte von der Gegenseite eine Mutter (0,8xD) vollständig und fest aufgeschraubt werden. Bei ausreichender Gewindelänge der Schraube wird zusätzlich die Verwendung einer Scheibe empfohlen.
3. Ringschrauben sollten vor dem Gebrauch auf festen Sitz und auffällige Beschädigung überprüft werden.
4. Ringschrauben mit Verformungen sollten nicht weiterbenutzt und nicht wieder eingeschraubt werden.
5. Die nachträgliche farbliche Kennzeichnung der Ringschrauben ist zu vermeiden, um Verwechslungen mit hochfesten Anschlagpunkten zu vermeiden.





Maße in mm

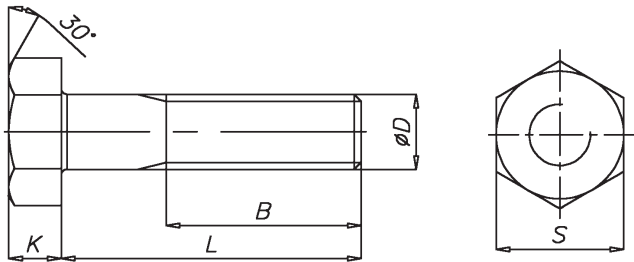

	M5	M6	M8	M10	M12	M16	M20	M24
1503								
P ¹⁾	0,8	1	1,25	1,5	1,75	2	2,5	3
B ²⁾	16	18	22	26	30	38	46	54
B ³⁾	22	24	28	32	36	44	52	60
B ⁴⁾	35	37	41	45	49	57	65	73
K	3,5	4	5,3	6,4	7,5	10	12,5	15
S	8	10	13	17	19	24	30	36

¹⁾ Gewindesteigung
²⁾ B für L ≤ 125
³⁾ B2 für 125 < L ≤ 200
⁴⁾ B2 für L > 200

VPE

L \ D	M5	M6	M8	M10	M12	M16	M20	M24
16	500	500	200	200	100	–	–	–
20	500	500	200	200	100	–	–	–
25	500	500	200	200	100	50	–	–
30	500	200	200	100	100	50	25	–
35	200	200	200	100	100	50	25	–
40	200	200	200	100	100	50	25	–
45	200	200	200	100	100	50	25	–
50	200	200	200	100	100	50	25	25
55	200	200	200	100	100	50	25	25
60	200	200	200	100	100	50	25	25
65	–	200	200	100	100	25	25	25
70	200	200	200	100	100	25	25	25
75	–	200	200	100	100	25	25	25
80	200	200	200	100	50	25	25	25
90	–	100	100	100	50	25	25	25
100	–	100	100	100	50	25	25	10
110	–	100	100	50	50	25	25	10
120	–	100	100	50	50	25	25	10
130	–	100	100	50	50	25	25	10
140	–	–	50	50	50	25	25	10
150	–	–	50	50	50	25	25	10
160	–	–	50	50	25	25	25	10
180	–	–	50	50	25	25	25	10
200	–	–	50	50	25	25	25	10
220	–	–	–	25	25	25	10	10
240	–	–	–	25	25	25	10	10
260	–	–	–	25	25	25	10	10
280	–	–	–	25	25	25	10	10
300	–	–	–	25	25	25	10	10
320	–	–	–	–	10	10	10	10
340	–	–	–	–	10	10	10	10
360	–	–	–	–	10	10	10	10
380	–	–	–	–	10	10	10	10
400	–	–	–	–	10	10	10	10

Die handelsüblichen Größen sind durch Angabe der VPE gekennzeichnet.
Lieferbar in Stahl 4.6





Maße in mm

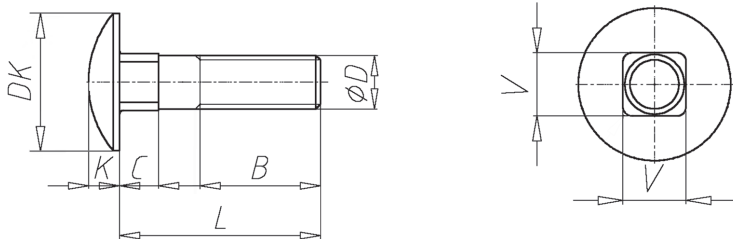

D	M5	M6	M8	M10	M12	M16	M20
P ¹⁾	0,8	1	1,25	1,5	1,75	2	2,5
B ²⁾	16	18	22	26	30	38	46
B ³⁾	22	24	28	32	36	44	52
B ⁴⁾	-	-	41	45	49	57	65
DK max	13,55	16,55	20,65	24,65	30,65	38,8	46,8
C max	4,1	4,6	5,6	6,6	8,75	12,9	15,9
K max	3,3	3,88	4,88	5,38	6,95	8,95	11,05
V max	5,48	6,48	8,58	10,58	12,7	16,7	20,84

¹⁾ Gewindesteigung

²⁾ B für L ≤ 125

³⁾ B für 125 < L ≤ 200

⁴⁾ B für L > 200

VPE

L \ D	M5	M6	M8	M10	M12	M16
12	–	200	–	–	–	–
16	500	200	200	–	–	–
20	500	200	200	100	–	–
25	200	200	200	100	50	–
30	200	200	200	100	50	–
35	200	200	200	100	50	–
40	200	200	200	100	50	25
45	200	200	200	100	50	25
50	200	200	200	100	50	25
55	200	200	200	100	50	–
60	200	200	200	100	50	25
65	200	200	100	100	50	–
70	200	200	100	100	50	25
75	–	200	100	100	50	–
80	200	200	100	100	50	25
90	200	200	100	100	50	25
100	200	200	100	100	50	25
110	–	100	100	50	50	25
120	–	100	100	50	50	25
130	–	100	100	50	50	25
140	–	100	50	50	50	25
150	–	100	50	50	50	–
160	–	100	50	50	25	25
170	–	–	50	50	25	–
180	–	–	50	50	25	25
190	–	–	–	50	25	–
200	–	–	50	50	25	25
220	–	–	–	25	25	25
240	–	–	–	25	25	25
260	–	–	–	25	25	25
280	–	–	–	25	25	25
300	–	–	–	25	25	25

Die handelsüblichen Größen sind durch Angabe der VPE gekennzeichnet.
Lieferbar in Güte: 4.6 sowie NIRO



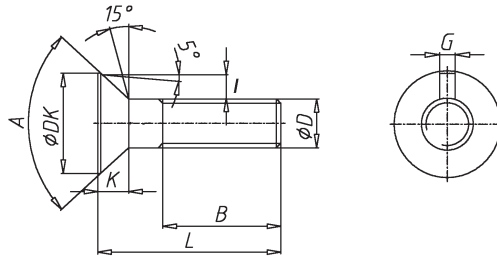

Maße in mm

D	M6	M8	M10	M12	M16	M20	M24
P ¹⁾	1	1,25	1,5	1,75	2	2,5	3
B ²⁾	18	22	26	30	38	46	54
B ³⁾	24	28	32	36	44	52	60
B ⁴⁾	-	41	45	49	57	65	73
DK max	12,55	16,55	19,65	24,65	32,8	32,8	38,8
G max	2,5	3	3,2	3,6	4,2	5,4	6,6
I min	2,8	3,5	4,2	5,7	7,5	5,7	6,7
K	4	5	5,5	7	9	11,5	13
A min	90°	90°	90°	90°	90°	60°	60°

¹⁾ Gewindesteigung

²⁾ B für L ≤ 125

³⁾ B für 125 < L ≤ 200

⁴⁾ B für L > 200

VPE

L \ D	M6	M8	M10	M12	M16	M20
20	200	–	–	–	–	–
25	200	200	100	100	–	–
30	200	200	100	100	50	–
35	200	200	100	100	50	–
40	200	200	100	100	50	25
45	200	200	100	100	50	25
50	200	200	100	100	50	25
55	100	100	100	50	50	25
60	100	100	100	50	50	25
65	–	100	100	50	25	25
70	–	100	100	50	25	25
80	–	–	50	50	25	25
90	–	–	50	50	25	25
100	–	–	50	50	25	25

Die handelsüblichen Größen sind durch Angabe der VPE gekennzeichnet.



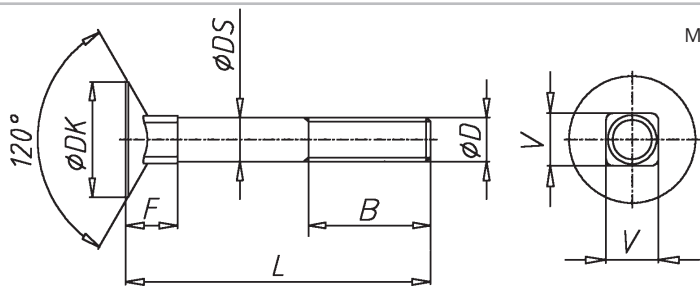

D	M6	M8	M10
P ¹⁾	1	1,25	1,5
B ²⁾	18	22	26
B ³⁾	24	28	32
B ⁴⁾	-	41	45
DK max	16,55	20,65	24,65
DS max	6	8	10
F max	7,45	9,45	11,55
V max	6,48	8,58	10,58

¹⁾ Gewindesteigung

²⁾ B für $L \leq 125$

³⁾ B für $125 < L \leq 200$

⁴⁾ B für $L > 200$

VPE

L \ D	M6	M8	M10
25	200	200	–
30	200	200	100
35	200	200	100
40	200	200	100
45	200	200	100
50	200	200	100
55	100	100	100
60	100	100	100
65	–	100	100
70	–	100	100
75	–	100	50
80	–	100	50
90	–	100	50
100	–	100	50

Die handelsüblichen Größen sind durch Angabe der VPE gekennzeichnet.
Lieferbar in Güte: 4.6

1



2



3



4



5



6



7



8



9



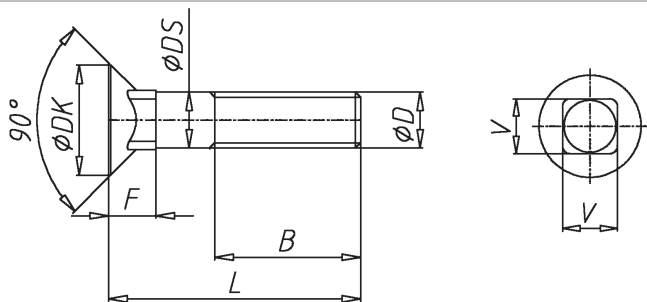

Maße in mm

D	M10	M12
P ¹⁾	1,5	1,75
DK max	19,65	24,65
DS max	10	12
F max	8,45	11,05
V max	10,58	12,7
B	26	30

¹⁾ Gewindesteigung

VPE

L \ D	M10	M12
25	100	–
30	100	100
35	100	100
40	100	100
50	100	100
60	100	50
70	–	50
80	–	50

Die handelsüblichen Größen sind durch Angabe der VPE gekennzeichnet.
Lieferbar in Güte: 4.6 , 8.8

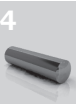

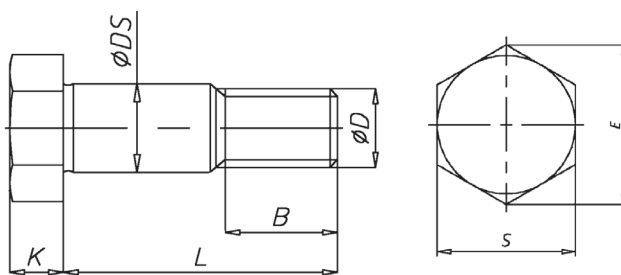

Maße in mm

D	M8	M10	M12	M14	M16	M20	M24	M27	M30	M36
P ¹⁾	1,25	1,5	1,75	2	2	2,5	3	3	3,5	4
B ²⁾	14,5	17,5	20,5	22	25	28,5	-	-	-	-
B ³⁾	16,5	19,5	22,5	24	27	30,5	36,5	39,5	43	49
B ⁴⁾	21,5	24,5	27,5	29	32	35,5	41,5	44,5	48	54
DS	9	11	13	15	17	21	25	28	32	38
E	14,38	17,77	19,85	22,78	26,17	32,95	39,55	45,2	50,85	60,79
K	5,3	6,4	7,5	8,8	10	12,5	15	17	19	22
S	13	16	18	21	24	30	36	41	46	55

Passschaft (DS) mit Toleranzfeld k6

¹⁾ Gewindesteigung

²⁾ B für L ≤ 50

³⁾ B für 50 < L ≤ 150

⁴⁾ B für L > 150

VPE

L \ D	M8	M10	M12	M14	M16	M20	M24
25	100	–	–	–	–	–	–
30	100	100	50	–	–	–	–
32	100	100	50	–	–	–	–
35	100	100	50	50	–	–	–
40	100	100	50	50	50	–	–
45	100	100	50	50	50	25	–
50	100	100	50	50	50	25	–
55	100	100	50	50	50	25	–
60	100	100	50	50	50	25	25
65	100	100	50	50	50	25	25
70	100	100	50	50	50	25	25
75	–	50	50	25	50	25	25
80	–	50	50	25	50	25	25
85	–	50	50	25	50	25	25
90	–	50	50	25	50	25	25
95	–	50	50	–	25	25	25
100	–	50	50	–	25	25	25
110	–	50	50	–	25	25	25
120	–	–	–	–	25	25	25
130	–	–	–	–	25	25	25
140	–	–	–	–	–	25	25
150	–	–	–	–	–	25	25
160	–	–	–	–	–	–	25
180	–	–	–	–	–	–	25

Die handelsüblichen Größen sind durch Angabe der VPE gekennzeichnet.



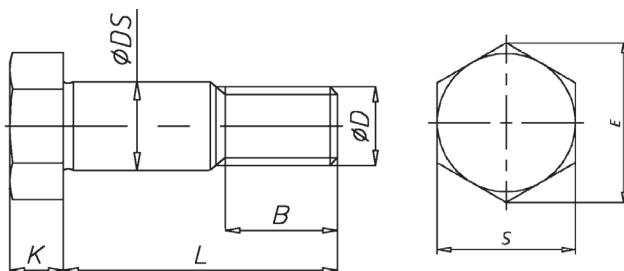

Maße in mm

D	M8	M10	M12	M14	M16	M20	M24
P ¹⁾	1,25	1,5	1,75	2	2	2,5	3
B ²⁾	11,5	13,5	15,5	17	19	22,5	26,5
B ³⁾	13,5	15,5	17,5	19	21	24,5	28,5
B ⁴⁾	18,5	20,5	22,5	24	26	29,5	33,5
DS	9	11	13	15	17	21	25
E	14,38	17,77	19,85	22,78	26,17	32,95	39,55
K	5,3	6,4	7,5	8,8	10	12,5	15
S	13	17	19	22	24	30	36

Passschaft (DS) mit Toleranzfeld k6

¹⁾ Gewindesteigung

²⁾ B für $L \leq 50$

³⁾ B für $50 < L \leq 150$

⁴⁾ B für $L > 150$

VPE

L \ D	M8	M10	M12	M14	M16	M20	M24
25	100	–	–	–	–	–	–
30	100	100	50	–	–	–	–
32	100	100	50	–	–	–	–
35	100	100	50	50	50	–	–
40	100	100	50	50	50	25	–
45	100	100	50	50	50	25	25
50	100	100	50	50	50	25	25
55	100	100	50	50	50	25	25
60	100	100	50	50	50	25	25
65	100	100	50	50	50	25	25
70	100	100	50	50	50	25	25
75	100	50	50	–	50	25	25
80	100	50	50	–	50	25	25
85	–	50	50	–	50	25	25
90	–	50	50	–	50	25	25
100	–	50	50	–	25	25	25
110	–	–	50	–	25	25	25
120	–	–	50	–	25	25	25
130	–	–	–	–	–	25	25
140	–	–	–	–	–	25	25
160	–	–	–	–	–	25	25

Die handelsüblichen Größen sind durch Angabe der VPE gekennzeichnet.





Maße in mm

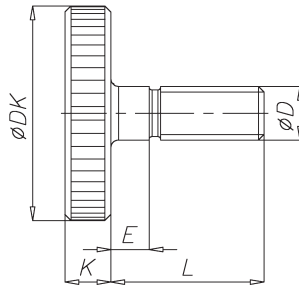

D	M3	M4	M5	M6	M8	M10
P ¹⁾	0,5	0,7	0,8	1	1,25	1,5
DK	12	16	20	24	30	36
E	2	3	3	4	5	6
K	2,5	3,5	4	5	6	8

¹⁾ Gewindesteigung

VPE

L \ D	M3	M4	M5	M6	M8	M10
6	100	–	–	–	–	–
8	100	100	100	–	–	–
10	100	100	100	50	–	–
12	100	100	100	50	50	–
16	100	100	100	50	50	–
20	100	100	100	50	50	50
25	–	100	100	50	50	50
30	–	100	100	50	50	50
35	–	–	100	50	50	50
40	–	–	100	50	50	50
50	–	–	–	50	50	50

Die handelsüblichen Größen sind durch Angabe der VPE gekennzeichnet.
Lieferbar in Stahl sowie NIRO



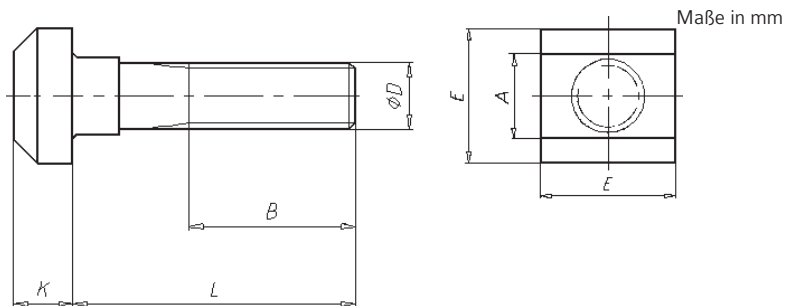

Nennmaß	D	A	E	K	B	L	VPE
6X6X25	M6	5,6	10	4	15	25	1
6X6X40	M6	5,6	10	4	28	40	1
6X6X63	M6	5,6	10	4	40	63	1
8X8X25	M8	7,6	13	6	15	25	1
8X8X32	M8	7,6	13	6	22	32	1
8X8X40	M8	7,6	13	6	25	40	1
8X8X50	M8	7,6	13	6	35	50	1
8X8X80	M8	7,6	13	6	50	80	1
10X10X40	M10	9,6	15	6	30	40	1
10X10X63	M10	9,6	15	6	45	63	1
10X10X100	M10	9,6	15	6	60	100	1
12X12X50	M12	11,6	18	7	35	50	1
12X12X63	M12	11,6	18	7	45	63	1
12X12X80	M12	11,6	18	7	55	80	1
12X12X125	M12	11,6	18	7	75	125	1
14X12X50	M12	13,6	22	8	35	50	1
14X12X63	M12	13,6	22	8	45	63	1
14X12X80	M12	13,6	22	8	55	80	1
14X12X125	M12	13,6	22	8	75	125	1
14X12X200	M12	13,6	22	8	120	200	1
16X16X63	M16	15,6	25	9	45	63	1
16X16X80	M16	15,6	25	9	55	80	1
16X16X100	M16	15,6	25	9	63	100	1

Nennmaß	D	A	E	K	B	L	VPE
16X16X160	M16	15,6	25	9	100	160	1
16X16X200	M16	15,6	25	9	125	200	1
16X16X250	M16	15,6	25	9	150	250	1
18X16X63	M16	17,6	28	10	45	63	1
18X16X80	M16	17,6	28	10	55	80	1
18X16X100	M16	17,6	28	10	63	100	1
18X16X160	M16	17,6	28	10	100	160	1
18X16X250	M16	17,6	28	10	150	250	1
20X20X80	M20	19,6	32	12	55	80	1
20X20X100	M20	19,6	32	12	65	100	1
20X20X125	M20	19,6	32	12	85	125	1
20X20X160	M20	19,6	32	12	100	160	1
20X20X200	M20	19,6	32	12	125	200	1
22X20X100	M20	21,6	35	14	65	100	1
22X20X125	M20	21,6	35	14	85	125	1
22X20X160	M20	21,6	35	14	100	160	1
22X20X200	M20	21,6	35	14	125	200	1
22X20X250	M20	21,6	35	14	150	250	1

Nutenführung gefräst.





Maße in mm

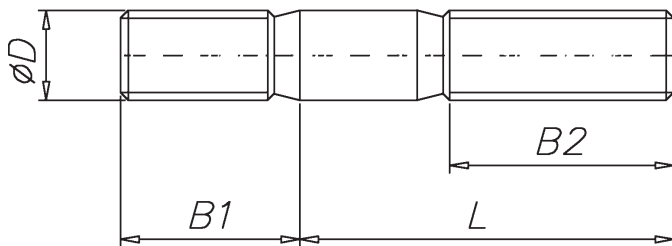

D	M6	M8	M10	M12	M16
P ¹⁾	1	1,25	1,5	1,75	2
B1	12	16	20	24	32
B2 ²⁾	18	22	26	30	38
B2 ³⁾	24	28	32	36	44
B2 ⁴⁾	-	-	45	49	57

Stiftschrauben nach dieser Norm werden vorwiegend zum Einschrauben in Aluminiumlegierungen verwendet. Für das Gewinde am Einschraubende gilt nach DIN 267-2 das Toleranzfeld Sk 6 nach DIN 13-51, wenn nicht in der Bezeichnung Fo (= ohne Festsitzgewinde) oder Sn 4 angegeben ist.

- ¹⁾ Gewindesteigung
- ²⁾ B2 für L <= 125
- ³⁾ B2 für 125 < L <= 200
- ⁴⁾ B2 für L > 200

VPE

L \ D	M6	M8	M10	M12	M16
20	100	100	100	–	–
25	100	100	100	100	–
30	100	100	100	100	–
35	100	100	100	100	25
40	100	100	100	50	25
45	–	100	100	50	25
50	–	100	100	50	25
60	–	–	–	50	25

Die handelsüblichen Größen sind durch Angabe der VPE gekennzeichnet.
Lieferbar in Güte: 5.8 und 8.8





Maße in mm

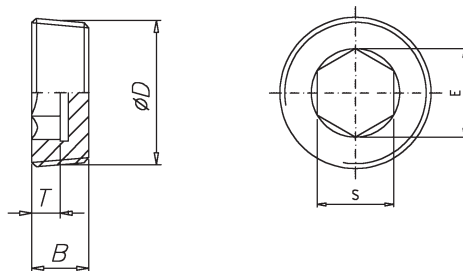

D	M8x1	M10x1	M12x1,5	M14x1,5	M16x1,5
B	8	8	10	10	10
E	4,6	5,7	6,9	8	9,2
S	4	5	6	7	8
T	4	4	5	5	5
VPE	50	50	50	50	50

D	M18x1,5	M20x1,5	M22x1,5	M24x1,5	M26x1,5	M27x2
B	10	10	10	12	12	12
E	9,2	11,4	11,4	13,7	13,7	13,7
S	8	10	10	12	12	12
T	5	5	5	6	6	6
VPE	25	25	25	25	25	25

M = Metrisches Feingewinde G = Rohrgewinde

Verschlusschrauben nach dieser Norm können zum Verschließen von Löchern mit zylindrischem Innengewinde verwendet werden. Es ist je nach Medium, Druck, Temperatur und Werkstoffpaarung keine Gewähr für Dichtheit gegeben. Deshalb wird empfohlen, je nach Verwendungszweck ein geeignetes Dichtmittel einzusetzen.

Verschlusschrauben nach dieser Norm dürfen nicht für Gas- und Trinkwasserleitungen verwendet werden.

Lieferbar in Stahl sowie Edelstahl

Maße in mm

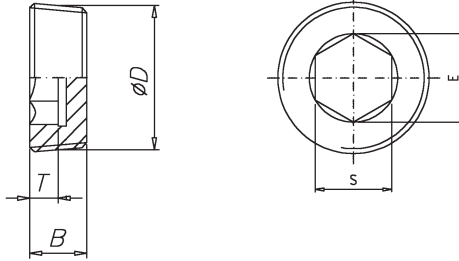

D	G1/8A	G1/4A	G3/8A	G1/2A	G3/4A	G1A	G1 1/4A	G1 1/2A
B	8	10	10	10	12	12	18	20
E	5,7	8	9,2	11,4	13,7	19,4	25,2	27,4
S	5	7	8	10	12	17	22	24
T	4	5	5	5	6	6	11,5	11,5
VPE	100	100	100	50	25	25	10	10

M = Metrisches Feingewinde G = Rohrgewinde

Verschlusschrauben nach dieser Norm können zum Verschließen von Löchern mit zylindrischem Innengewinde verwendet werden. Es ist je nach Medium, Druck, Temperatur und Werkstoffpaarung keine Gewähr für Dichtheit gegeben. Deshalb wird empfohlen, je nach Verwendungszweck ein geeignetes Dichtmittel einzusetzen.

Verschlusschrauben nach dieser Norm dürfen nicht für Gas- und Trinkwasserleitungen verwendet werden.

Lieferbar in Stahl sowie Edelstahl



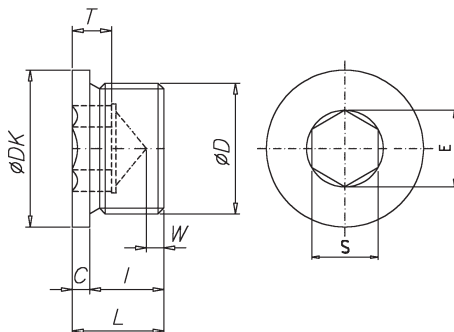

Maße in mm

D	M10x1	M12x1	M12x1,5	M14x1,5
C	3	3	3	3
DK	14	17	17	19
E	5,7	6,9	6,9	6,9
I	8	12	12	12
L	11	15	15	15
S	5	6	6	6
T	5	7	7	7
W	3	3	3	3
VPE	50	50	50	50

D	M16x1,5	M18x1,5	M20x1,5	M22x1,5	M24x1,5
C	3	4	4	4	4
DK	21	23	25	27	29
E	9,2	9,2	11,4	11,4	13,7
I	12	12	14	14	14
L	15	15	18	18	18
S	8	8	10	10	12
T	7,5	7,5	7,5	7,5	7,5
W	3	3	4	4	4
VPE	50	50	25	25	25

M = Metrisches Feingewinde G = Rohrgewinde

Verschlusschrauben nach dieser Norm können zum Verschließen von Löchern mit zylindrischem Innengewinde verwendet werden. Es ist je nach Medium, Druck, Temperatur und Werkstoffpaarung keine Gewähr für Dichtheit gegeben. Deshalb wird empfohlen, je nach Verwendungszweck ein geeignetes Dichtmittel einzusetzen.

Verschlusschrauben nach dieser Norm dürfen nicht für Gas- und Trinkwasserleitungen verwendet werden.

Lieferbar in Stahl sowie Edelstahl

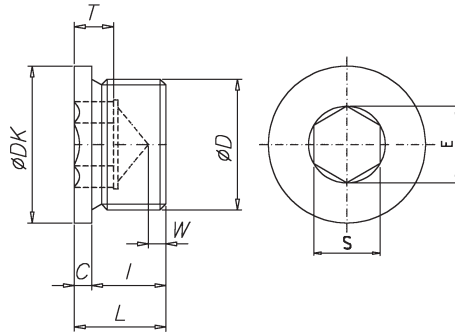

Maße in mm

D	G1/8	G1/4	G3/8	G1/2	G3/4	G1	G1 1/4A	G1 1/2A	G2A
C	3	3	3	4	4	5	5	5	5
DK	14	18	22	26	32	39	49	55	68
E	5,7	6,9	9,2	11,4	13,7	19,4	25,2	27,4	36,6
I	8	12	12	14	16	16	16	16	20
L	11	15	15	18	20	21	21	21	25
S	5	6	8	10	12	17	22	24	32
T	5	7	7,5	7,5	9	9	10,5	10,5	14
W	3	3	3	4	4	4	4	4	4
VPE	50	50	50	50	25	25	10	10	10

M = Metrisches Feingewinde G = Rohrgewinde

Verschlusschrauben nach dieser Norm können zum Verschließen von Löchern mit zylindrischem Innengewinde verwendet werden. Es ist je nach Medium, Druck, Temperatur und Werkstoffpaarung keine Gewähr für Dichtheit gegeben. Deshalb wird empfohlen, je nach Verwendungszweck ein geeignetes Dichtmittel einzusetzen.

Verschlusschrauben nach dieser Norm dürfen nicht für Gas- und Trinkwasserleitungen verwendet werden.

Lieferbar in Stahl sowie Edelstahl



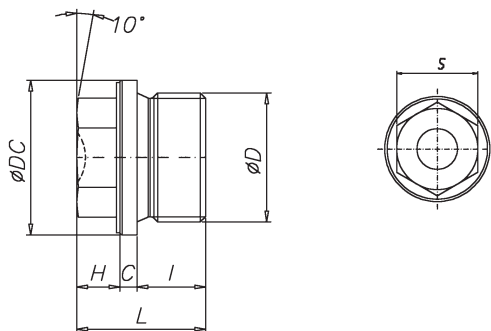

Maße in mm

D	M10x1	M12x1,5	M14x1,5	M16x1,5
C	3	3	3	3
DC	14	17	19	21
E	10,89	14,2	14,2	18,72
H	6	6	6	6
I	8	12	12	12
L	17	21	21	21
S	10	13	13	17
VPE	100	100	50	50

D	M18x1,5	M20x1,5	M22x1,5	M24x1,5
C	4	4	4	4
DC	23	25	27	29
E	18,72	20,88	20,88	23,91
H	8	8	8	9
I	12	14	14	14
L	24	26	26	27
S	17	19	19	22
VPE	25	25	25	25

M = Metrisches Feingewinde G = Rohrgewinde

Verschlusschrauben nach dieser Norm können zum Verschließen von Löchern mit zylindrischem Innengewinde verwendet werden. Es ist je nach Medium, Druck, Temperatur und Werkstoffpaarung keine Gewähr für Dichtheit gegeben. Deshalb wird empfohlen, je nach Verwendungszweck ein geeignetes Dichtmittel einzusetzen.

Verschlusschrauben nach dieser Norm dürfen nicht für Gas- und Trinkwasserleitungen verwendet werden.

Lieferbar in Stahl sowie Edelstahl

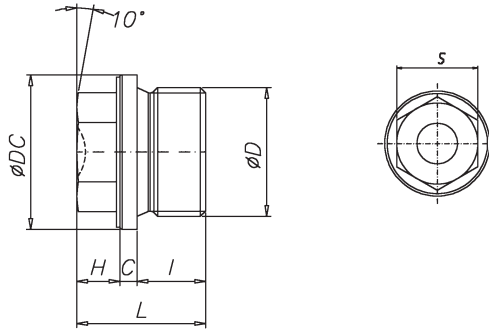

Maße in mm

D	G1/8	G1/4	G3/8	G1/2	G3/4	G1	G11/4A	G11/2A	G2A
C	3	3	3	4	4	5	5	5	5
DC	14	18	22	26	32	39	49	55	68
E	10,89	14,2	18,72	20,88	26,17	29,56	32,95	32,95	39,55
H	6	6	6	8	10	11	12	12	15
I	8	12	12	14	16	16	16	16	20
L	17	21	21	26	30	32	33	33	40
S	10	13	17	19	24	27	30	30	36
VPE	50	50	50	50	25	25	10	10	10

M = Metrisches Feingewinde G = Rohrgewinde

Verschlusschrauben nach dieser Norm können zum Verschließen von Löchern mit zylindrischem Innengewinde verwendet werden. Es ist je nach Medium, Druck, Temperatur und Werkstoffpaarung keine Gewähr für Dichtheit gegeben. Deshalb wird empfohlen, je nach Verwendungszweck ein geeignetes Dichtmittel einzusetzen.

Verschlusschrauben nach dieser Norm dürfen nicht für Gas- und Trinkwasserleitungen verwendet werden.

Lieferbar in Stahl sowie Edelstahl





Maße in mm

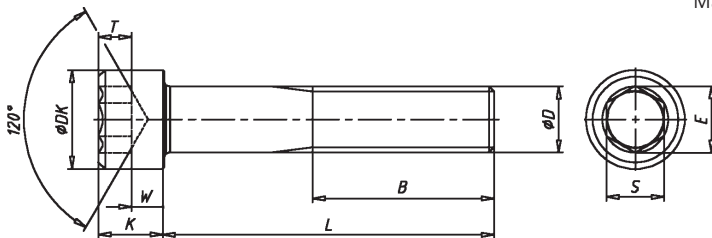

D	M3	M4	M5	M6	M8	M10	M12
P ¹⁾	0,5	0,7	0,8	1	1,25	1,5	1,75
B	18	20	22	24	28	32	36
DK	5,5	7	8,5	10	13	16	18
K	3	4	5	6	8	10	12
E	2,87	3,44	4,58	5,72	6,86	9,15	11,43
S	2,5	3	4	5	6	8	10
T	1,3	2	2,5	3	4	5	6
W	1,15	1,4	1,9	2,3	3	4	4,8

D	M14	M16	M18	M20	M24	M27	M30
P ¹⁾	2	2	2,5	2,5	3	3	3,5
B	40	44	48	52	60	66	72
DK	21	24	27	30	36	40	45
K	14	16	18	20	24	27	30
E	13,72	16	16	19,44	21,73	21,73	25,15
S	12	14	14	17	19	19	22
T	7	8	9	10	12	13,5	15,5
W	5,8	6,8	7,8	8,6	10,4	11,9	13,1

¹⁾ Gewindesteigung

VPE

L \ D	M3	M4	M5	M6	M8	M10	M12	M14	M16	M18	M20	M24	M27	M30
4	500	500	-	-	-	-	-	-	-	-	-	-	-	-
5	500	500	-	-	-	-	-	-	-	-	-	-	-	-
6	500	500	500	500	-	-	-	-	-	-	-	-	-	-

L \ D	M3	M4	M5	M6	M8	M10	M12	M14	M16	M18	M20	M24	M27	M30
8	500	500	500	500	200	-	-	-	-	-	-	-	-	-
10	500	500	500	500	200	200	-	-	-	-	-	-	-	-
12	500	500	500	500	200	200	-	-	-	-	-	-	-	-
14	500	500	500	500	200	200	100	-	-	-	-	-	-	-
16	500	500	500	500	200	200	100	-	50	-	-	-	-	-
18	500	500	500	500	200	200	-	-	-	-	-	-	-	-
20	500	500	500	500	200	200	100	100	50	-	25	-	-	-
22	500	500	500	500	200	200	100	-	-	-	-	-	-	-
25	500	500	500	500	200	200	100	100	50	-	25	-	-	-
30	500	500	500	500	200	200	100	100	50	50	25	25	-	-
35	500	500	500	200	200	200	100	100	50	50	25	-	-	-
40	500	500	200	200	200	100	100	100	50	50	25	25	-	-
45	500	500	200	200	200	100	100	50	50	50	25	25	-	-
50	500	500	200	200	200	100	100	50	50	50	25	25	10	10
55	500	500	200	200	200	100	100	50	50	25	25	25	-	-
60	500	500	200	200	200	100	100	50	50	25	25	25	10	10
65	500	200	200	200	200	100	50	50	25	-	25	25	-	10
70	500	200	200	200	200	100	50	50	25	25	25	25	10	10
75	-	200	200	200	200	100	50	50	25	-	25	25	-	-
80	-	200	200	200	200	100	50	50	25	25	25	25	10	10
85	-	200	200	200	200	100	50	-	25	-	25	25	-	-
90	-	200	200	200	200	100	50	50	25	25	25	25	10	10
95	-	-	200	200	200	100	50	-	25	-	-	-	-	-
100	-	200	200	200	100	100	50	50	25	25	25	10	10	10
110	-	200	100	100	100	100	50	50	25	25	25	10	10	10
120	-	200	100	100	100	50	50	50	25	25	25	10	10	10
130	-	-	100	100	100	50	50	50	25	-	25	10	10	10
140	-	-	100	100	100	50	50	25	25	25	25	10	10	10
150	-	-	100	100	100	50	50	25	25	25	10	10	10	10
160	-	-	100	100	100	50	25	25	25	25	10	10	-	10
170	-	-	100	100	100	50	25	-	25	-	10	10	-	10
180	-	-	100	100	100	50	25	25	25	25	10	10	-	10
190	-	-	100	-	100	50	25	-	25	-	10	10	-	10
200	-	-	100	100	100	50	25	25	25	25	10	10	-	10
210	-	-	100	-	100	50	25	-	25	-	10	-	-	-
220	-	-	-	-	100	50	25	25	25	-	10	10	-	5
230	-	-	-	-	100	50	25	-	25	-	-	-	-	5
240	-	-	-	-	100	50	25	-	25	-	10	10	-	5
250	-	-	-	-	100	50	25	-	25	-	10	10	-	5
260	-	-	-	-	100	50	25	-	25	-	10	10	-	5
280	-	-	-	-	100	50	25	-	25	-	10	10	-	5
300	-	-	-	-	100	50	25	-	25	-	10	10	-	5

Die handelsüblichen Größen sind durch Angabe der VPE gekennzeichnet.
Lieferbar in Güte: 8.8, 10.9, 12.9 sowie Edelstahl A2 und Edelstahl A4





Maße in mm

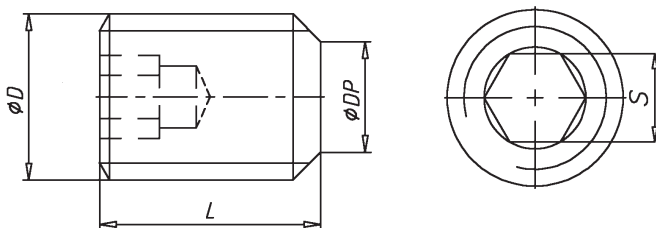

D	M2	M2,5	M3	M4	M5	M6	M8
P ¹⁾	0,4	0,45	0,5	0,7	0,8	1	1,25
DP	1	1,5	2	2,5	3,5	4	5,5
S	0,9	1,3	1,5	2	2,5	3	4

D	M10	M12	M14	M16	M18	M20	M24
P ¹⁾	1,5	1,75	2	2	2,5	2,5	3
DP	7	8,5	10	12	13	15	18
S	5	6	6	8	10	10	12

Gewindestifte 45H sind für die Verwendung als Druckstück vorgesehen. Aufgrund ihrer hohen Härte sind sie nicht zur Übertragung von Zugkräften geeignet. Bei Anwendungsfällen, in denen Zugkräfte in den Stiften auftreten, kann es zum Sprödbruch kommen.

¹⁾ Gewindesteigung

VPE

L \ D	M2	M2,5	M3	M4	M5	M6	M8	M10	M12	M16	M20
2	1000	–	–	–	–	–	–	–	–	–	–
2,5	1000	–	1000	–	–	–	–	–	–	–	–
3	1000	1000	1000	1000	–	–	–	–	–	–	–
4	1000	1000	1000	1000	1000	500	–	–	–	–	–
5	1000	1000	1000	1000	1000	500	200	–	–	–	–
6	1000	1000	1000	1000	1000	500	200	–	–	–	–
8	1000	1000	1000	1000	1000	500	200	200	100	–	–
10	1000	1000	1000	1000	1000	500	200	200	100	100	–
12	–	1000	1000	1000	1000	500	200	200	100	100	–
14	–	–	1000	1000	1000	500	200	200	100	–	–
16	–	1000	1000	1000	1000	500	200	200	100	100	–
18	–	–	1000	1000	1000	500	200	–	–	–	–
20	–	–	1000	1000	500	500	200	200	100	50	25
25	–	–	1000	500	500	500	200	200	100	50	25
30	–	–	1000	500	500	200	200	200	100	50	25
35	–	–	–	500	500	200	200	100	100	50	25
40	–	–	–	500	500	200	100	100	100	50	25
45	–	–	–	–	200	200	100	100	50	50	25
50	–	–	–	200	200	200	100	100	50	50	25
55	–	–	–	–	–	200	100	100	50	50	25
60	–	–	–	–	–	200	100	100	50	50	25
70	–	–	–	–	–	200	100	100	50	50	25
80	–	–	–	–	–	200	100	100	50	50	25
90	–	–	–	–	–	–	100	100	50	50	25
100	–	–	–	–	–	100	100	100	50	25	10
110	–	–	–	–	–	–	100	100	50	25	10
120	–	–	–	–	–	–	100	100	50	25	10

Die handelsüblichen Größen sind durch Angabe der VPE gekennzeichnet.
Lieferbar in Güte: 45H sowie Edelstahl A2 und Edelstahl A4





Maße in mm

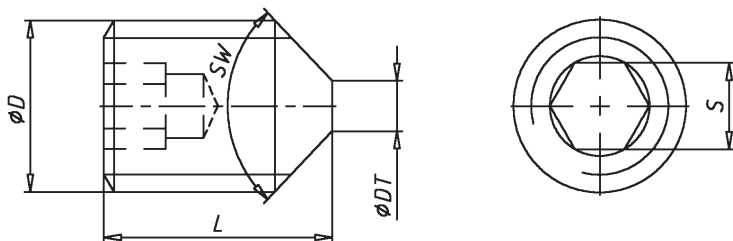

D	M2	M2,5	M3	M4	M5	M6
P ¹⁾	0,4	0,45	0,5	0,7	0,8	1
DT	-	-	-	-	-	1,5
S	0,9	1,3	1,5	2	2,5	3

D	M8	M10	M12	M14	M16	M20	M24
P ¹⁾	1,25	1,5	1,75	2	2	2,5	3
DT	2	2,5	3	4	4	5	6
S	4	5	6	6	8	10	12

Der Winkel (SW) beträgt 90°. Für Längen kleiner gleich dem Durchmesser gilt ein Winkel (SW) von 120°. Gewindestifte 45H sind für die Verwendung als Druckstück vorgesehen. Aufgrund ihrer hohen Härte sind sie nicht zur Übertragung von Zugkräften geeignet. Bei Anwendungsfällen, in denen Zugkräfte in den Stiften auftreten, kann es zum Sprödbruch kommen.

¹⁾ Gewindesteigung

VPE

L \ D	M2	M2,5	M3	M4	M5	M6	M8	M10	M12	M16	M20
3	1000	1000	1000	–	–	–	–	–	–	–	–
4	1000	1000	1000	1000	1000	–	–	–	–	–	–
5	1000	1000	1000	1000	1000	500	–	–	–	–	–
6	1000	1000	1000	1000	1000	500	200	–	–	–	–
8	–	1000	1000	1000	1000	500	200	–	–	–	–
10	–	1000	1000	1000	500	500	200	200	100	–	–
12	–	–	1000	1000	500	500	200	200	100	–	–
14	–	–	1000	1000	500	500	200	200	100	–	–
16	–	–	1000	1000	500	500	200	200	100	50	–
18	–	–	1000	1000	500	500	200	–	–	–	–
20	–	–	1000	1000	500	500	200	100	100	50	25
25	–	–	1000	1000	200	500	200	100	100	50	25
30	–	–	1000	1000	200	200	200	100	100	50	25
35	–	–	–	1000	200	200	200	100	100	50	25
40	–	–	–	500	200	200	200	100	100	50	25
45	–	–	–	–	200	200	200	100	100	50	25
50	–	–	–	–	200	200	200	100	100	50	25
60	–	–	–	–	–	200	200	100	100	25	25
70	–	–	–	–	–	200	200	100	50	25	25
80	–	–	–	–	–	–	200	100	50	25	25
90	–	–	–	–	–	–	200	100	50	25	25
100	–	–	–	–	–	–	–	100	25	25	25

Die handelsüblichen Größen sind durch Angabe der VPE gekennzeichnet.
Lieferbar in Güte: 45H sowie Edelstahl A2 und Edelstahl A4





Maße in mm

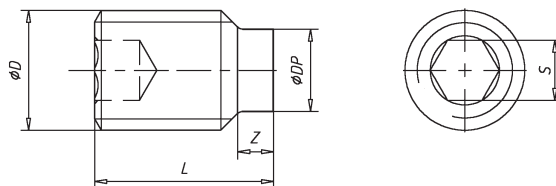

D	M3	M4	M5	M6	M8	M10	M12	M14	M16	M20	M24
P ¹⁾	0,5	0,7	0,8	1	1,25	1,5	1,75	2	2	2,5	3
DP	2	2,5	3,5	4	5,5	7	8,5	10	12	15	18
S	1,5	2	2,5	3	4	5	6	6	8	10	12
Z max	1,75	2,25	2,75	3,25	4,3	5,3	6,3	7,36	8,36	10,36	12,43

Bei kurzen Längen reduzierte Zapfenlänge (Z) beachten.

Gewindestifte 45H sind für die Verwendung als Druckstück vorgesehen. Aufgrund ihrer hohen Härte sind sie nicht zur Übertragung von Zugkräften geeignet. Bei Anwendungsfällen, in denen Zugkräfte in den Stiften auftreten, kann es zum Sprödbruch kommen.

¹⁾ Gewindesteigung

VPE

L \ D	M3	M4	M5	M6	M8	M10	M12	M16	M20	M24
3	1000	–	–	–	–	–	–	–	–	–
4	1000	1000	1000	–	–	–	–	–	–	–
5	1000	1000	1000	500	–	–	–	–	–	–
6	1000	1000	1000	500	200	–	–	–	–	–
8	1000	1000	1000	500	200	–	–	–	–	–
10	1000	1000	1000	500	200	200	100	–	–	–
12	1000	1000	1000	500	200	200	100	–	–	–
14	1000	1000	1000	500	200	200	100	–	–	–
16	1000	1000	500	500	200	200	100	50	–	–
20	1000	500	500	200	200	100	100	50	25	–
25	1000	500	500	200	200	100	100	50	25	–
30	1000	500	500	200	200	100	100	50	25	25
35	–	500	500	200	200	100	100	50	25	25
40	–	500	500	200	200	100	100	25	25	25
45	–	–	500	200	200	100	100	25	25	25
50	–	–	200	200	200	100	100	25	25	25
55	–	–	–	200	200	100	100	25	25	–
60	–	–	–	200	200	100	100	25	25	25
70	–	–	–	200	200	100	50	25	25	25
80	–	–	–	–	200	100	50	25	25	25
90	–	–	–	–	–	100	50	25	25	25
100	–	–	–	–	–	50	50	25	25	25

Die handelsüblichen Größen sind durch Angabe der VPE gekennzeichnet.
Lieferbar in Güte: 45H sowie Edelstahl A2 und Edelstahl A4





Maße in mm

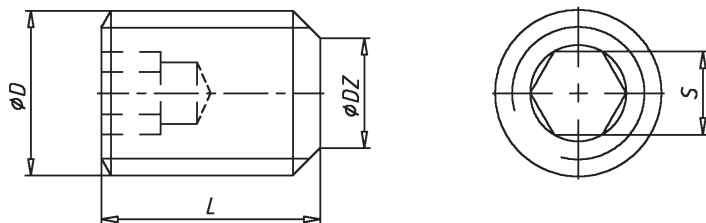

D	M2	M2,5	M3	M4	M5	M6
P ¹⁾	0,4	0,45	0,5	0,7	0,8	1
DZ	1	1,2	1,4	2	2,5	3
S	0,9	1,3	1,5	2	2,5	3

D	M8	M10	M12	M14	M16	M20	M24
P ¹⁾	1,25	1,5	1,75	2	2	2,5	3
DZ	5	6	8	9	10	14	18
S	4	5	6	6	8	10	12

Gewindestifte 45H sind für die Verwendung als Druckstück vorgesehen. Aufgrund ihrer hohen Härte sind sie nicht zur Übertragung von Zugkräften geeignet. Bei Anwendungsfällen, in denen Zugkräfte in den Stiften auftreten, kann es zum Sprödbruch kommen.

¹⁾ Gewindesteigung

VPE

L \ D	M2	M2,5	M3	M4	M5	M6	M8	M10	M12	M16	M20
2	1000	–	–	–	–	–	–	–	–	–	–
3	1000	1000	1000	–	–	–	–	–	–	–	–
4	1000	1000	1000	1000	1000	1000	–	–	–	–	–
5	1000	1000	1000	1000	1000	1000	–	–	–	–	–
6	1000	1000	1000	1000	1000	1000	500	–	–	–	–
8	1000	1000	1000	1000	1000	1000	500	200	–	–	–
10	1000	1000	1000	1000	500	500	200	200	100	–	–
12	–	1000	1000	1000	500	500	200	200	100	–	–
14	–	–	1000	1000	500	500	200	200	100	–	–
16	–	–	1000	1000	500	500	200	200	100	50	–
18	–	–	1000	1000	500	500	–	–	–	–	–
20	–	–	1000	500	500	500	200	200	100	50	50
25	–	–	1000	500	500	200	200	200	100	50	50
30	–	–	1000	500	500	200	200	200	100	50	50
35	–	–	–	500	500	200	200	200	100	50	25
40	–	–	–	–	200	200	200	200	100	50	25
45	–	–	–	–	–	200	200	200	100	50	25
50	–	–	–	–	200	200	200	100	50	50	25
60	–	–	–	–	–	–	200	100	50	25	25
70	–	–	–	–	–	–	200	100	50	25	25
80	–	–	–	–	–	–	–	100	50	25	25

Die handelsüblichen Größen sind durch Angabe der VPE gekennzeichnet.
Lieferbar in Güte: 45H sowie Edelstahl A2 und Edelstahl A4



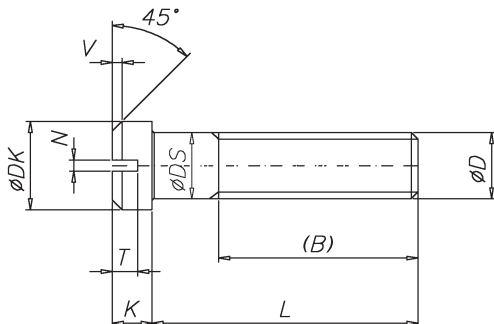

Maße in mm

D	M2	M2,5	M3	M4	M5	M6	M8
P ¹⁾	0,4	0,45	0,5	0,7	0,8	1	1,25
DK max	2,8	3,5	4	5,5	6,5	8	10
DS max	2	2,5	3	4	5	6	8
K	1,2	1,5	1,8	2,4	2,7	3,1	3,8
N	0,3	0,4	0,5	0,6	0,8	1	1,2
T	0,6	0,75	0,9	1,2	1,3	1,5	1,9
V	0,3	0,4	0,45	0,6	0,7	0,8	0,9
B	6	7,5	9	12	15	18	24

¹⁾ Gewindesteigung

VPE

L \ D	M2	M2,5	M3	M4	M5	M6	M8
3	200	200	200	–	–	–	–
4	200	200	200	–	–	–	–
5	200	200	200	200	–	–	–
6	200	200	200	200	100	–	–
8	200	200	200	200	100	100	–
10	–	200	200	200	100	100	100
12	–	200	200	200	100	100	100
16	–	–	200	200	100	100	100
20	–	–	–	200	100	100	100
25	–	–	–	–	100	100	100
30	–	–	–	–	–	100	100

Die handelsüblichen Größen sind durch Angabe der VPE gekennzeichnet.

Lieferbar in Güte: 5.8 sowie NIRO

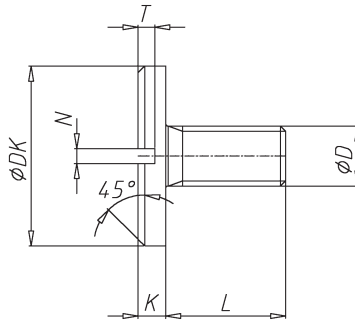

Maße in mm



D	M2	M2,5	M3	M4	M5	M6	M8	M10
P ¹⁾	0,4	0,45	0,5	0,7	0,8	1	1,25	1,5
DK max	6	7	8	12	16	20	25	30
K	1,2	1,5	1,8	2,4	2,7	3,1	3,8	4,6
N	0,5	0,6	0,8	1	1,2	1,6	2	2,5
T	0,6	0,75	0,9	1,2	1,3	1,5	1,9	2,3

¹⁾ Gewindesteigung

VPE

L \ D	M2	M2,5	M3	M4	M5	M6	M8	M10
4	200	200	200	–	–	–	–	–
5	200	200	200	200	–	–	–	–
6	200	200	200	200	100	–	–	–
8	200	200	200	200	100	–	–	–
10	–	–	200	200	100	100	–	–
12	–	–	200	200	100	100	100	–
16	–	–	–	200	100	100	100	100
20	–	–	–	–	–	100	100	100
25	–	–	–	–	–	–	100	100
30	–	–	–	–	–	–	–	100

Die handelsüblichen Größen sind durch Angabe der VPE gekennzeichnet.
Lieferbar in Güte: 5.8 sowie NIRO



Maße in mm

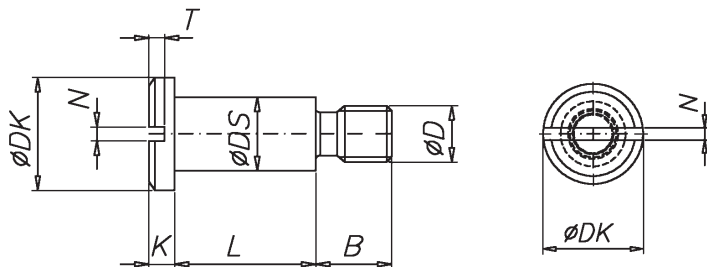

D	M2	M2,5	M3	M4	M5	M6	M8	M10
P ¹⁾	0,4	0,45	0,5	0,7	0,8	1	1,25	1,5
B	3	3,5	4,5	6	7	9	11	13,5
DK max	4,5	6	7	8,5	11	13	16	20
DS max	2,8	3,5	4	5,5	7	8	10	13
K	1,2	1,5	1,8	2,4	2,7	3,1	3,8	4,6
N	0,5	0,6	0,8	1	1,2	1,6	2	2,5
T	0,6	0,75	0,9	1,2	1,3	1,5	1,9	2,3

¹⁾ Gewindesteigung

VPE

L \ D	M2	M2,5	M3	M4	M5	M6	M8	M10
1,8	–	–	200	–	–	–	–	–
2	200	–	200	200	100	100	–	–
2,5	200	200	200	200	100	–	–	–
3	200	200	200	200	100	100	–	–
4	200	200	200	200	100	100	100	–
5	200	200	200	200	100	100	100	100
6	200	200	200	200	100	100	100	100
8	–	200	200	200	100	100	100	100
10	–	200	200	200	100	100	100	100
12	–	–	200	200	100	100	100	100
16	–	–	200	200	100	100	100	100
20	–	–	–	200	100	100	100	100
25	–	–	–	–	–	100	100	100

Die handelsüblichen Größen sind durch Angabe der VPE gekennzeichnet.

Lieferbar in Güte: 5.8 sowie NIRO

Maße in mm

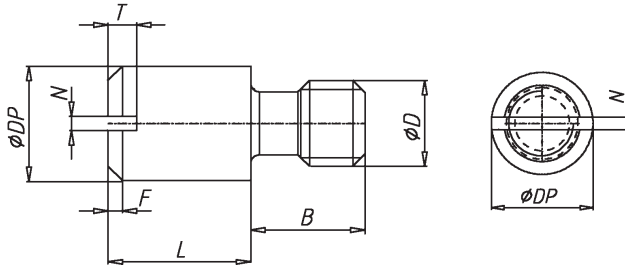

D	M3	M4	M5	M6
P ¹⁾	0,5	0,7	0,8	1
B	4,5	6	7	8
DP	4	5,5	6,5	8
F	0,5	0,8	0,8	1
N	0,5	0,6	0,8	1
T	0,8	1,12	1,28	1,6

¹⁾ Gewindesteigung

VPE

L \ D	M3	M4	M5	M6
3	200	200	–	–
4	200	200	100	–
5	200	200	100	100
6	200	200	100	100
8	200	200	100	100
10	–	200	100	100
12	–	–	–	100

Die handelsüblichen Größen sind durch Angabe der VPE gekennzeichnet.
Lieferbar in Güte: 5.8 sowie NIRO



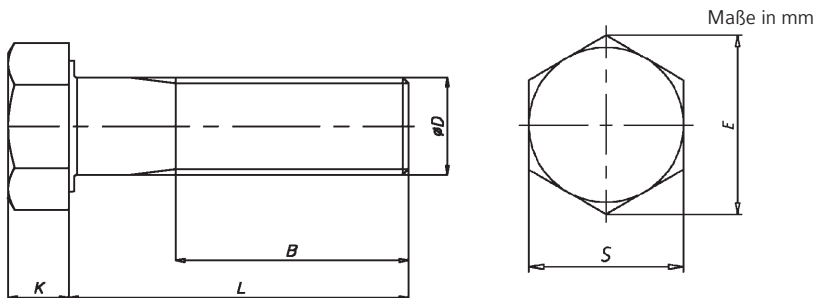

D	M4	M5	M6	M8	M10	M12	M14	M16
P ¹⁾	0,7	0,8	1	1,25	1,5	1,75	2	2
B ²⁾	14	16	18	22	26	30	34	38
B ³⁾	-	22	24	28	32	36	40	44
B ⁴⁾	-	-	-	-	45	49	53	57
K	2,8	3,5	4	5,3	6,4	7,5	8,8	10
S	7	8	10	13	17	19	22	24
E	7,66	8,79	11,05	14,38	18,9	21,1	24,49	26,75

D	M18	M20	M22	M24	M27	M30	M33	M36
P ¹⁾	2,5	2,5	2,5	3	3	3,5	3,5	4
B ²⁾	42	46	50	54	60	66	72	78
B ³⁾	48	52	56	60	66	72	78	84
B ⁴⁾	61	65	69	73	79	85	91	97
K	11,5	12,5	14	15	17	18,7	21	22,5
S	27	30	32	36	41	46	50	55
E	30,14	33,53	35,72	39,98	45,2	50,85	55,37	60,79

¹⁾ Gewindesteigung

²⁾ B für L ≤ 125

³⁾ B für 125 < L ≤ 200

⁴⁾ B für L > 200

VPE

L \ D	M4	M5	M6	M8	M10	M12	M14	M16	M18	M20	M22	M24	M27	M30	M33	M36
20	–	500	–	–	–	–	–	–	–	–	–	–	–	–	–	–
25	500	500	–	–	–	–	–	–	–	–	–	–	–	–	–	–
30	500	500	500	200	–	–	–	–	–	–	–	–	–	–	–	–
35	500	500	500	200	100	–	–	–	–	–	–	–	–	–	–	–
40	500	200	200	200	100	100	–	–	–	–	–	–	–	–	–	–
45	200	200	200	200	100	100	–	–	–	–	–	–	–	–	–	–
50	200	200	200	200	100	100	50	50	–	–	–	–	–	–	–	–
55	–	200	200	200	100	100	50	50	–	25	–	–	–	–	–	–
60	200	200	200	200	100	100	50	50	25	25	–	–	–	–	–	–
65	–	200	200	200	100	50	50	25	25	25	–	–	–	–	–	–
70	200	200	200	200	100	50	50	25	25	25	25	25	–	–	–	–
75	–	–	200	200	100	50	50	25	25	25	25	25	–	–	–	–
80	200	200	200	200	100	50	50	25	25	25	25	25	10	10	–	–
85	–	–	100	100	100	50	50	25	–	25	–	10	–	–	–	–
90	–	–	100	100	100	50	50	25	25	25	25	10	10	10	–	–
95	–	–	100	100	100	50	50	25	–	25	–	10	–	–	–	–
100	–	–	100	100	100	50	50	25	25	25	25	10	10	10	10	5
110	–	–	100	100	50	50	25	25	25	25	25	10	10	10	5	5
120	–	–	100	100	50	50	25	25	25	25	10	10	10	10	5	5
130	–	–	100	100	50	50	25	25	25	25	10	10	10	10	5	5
140	–	–	100	100	50	50	25	25	25	25	10	10	10	10	5	5
150	–	–	100	100	50	50	25	25	25	25	10	10	10	10	5	5
160	–	–	–	100	50	25	25	25	25	10	10	10	10	10	5	5
170	–	–	–	100	50	25	25	25	–	10	–	10	10	10	5	5
180	–	–	–	100	50	25	25	25	25	10	10	10	10	10	5	5
190	–	–	–	100	50	25	25	25	–	10	–	10	10	10	5	5
200	–	–	–	100	50	25	25	25	25	10	10	10	10	10	5	5
210	–	–	–	–	50	25	25	25	–	10	–	10	10	5	5	5
220	–	–	–	–	50	25	25	25	25	10	10	10	10	5	5	5
230	–	–	–	–	50	25	25	25	–	10	–	10	10	5	5	5
240	–	–	–	–	50	25	25	25	25	10	–	10	10	5	5	5
250	–	–	–	–	–	25	25	25	–	10	–	10	10	5	5	5
260	–	–	–	–	25	25	25	25	25	10	–	10	10	5	5	5
270	–	–	–	–	–	–	–	–	–	10	–	10	10	5	5	5
280	–	–	–	–	25	25	–	25	–	10	–	10	10	5	5	5
300	–	–	–	–	–	25	–	25	25	10	–	10	10	5	5	5

Die handelsüblichen Größen sind durch Angabe der VPE gekennzeichnet.
Lieferbar in Güte: 8.8, 10.9 sowie Edelstahl A2 und Edelstahl A4



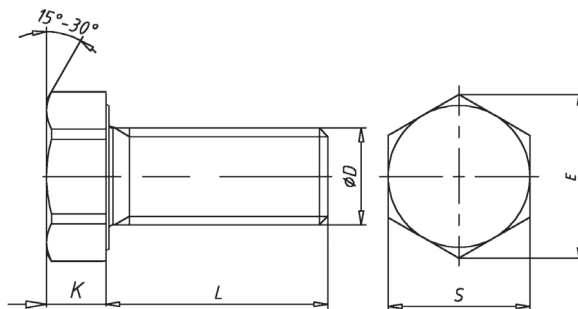

Maße in mm

D	M4	M5	M6	M8	M10	M12	M14	M16
P ¹⁾	0,7	0,8	1	1,25	1,5	1,75	2	2
E	7,66	8,79	11,05	14,38	18,9	21,1	24,49	26,75
K	2,8	3,5	4	5,3	6,4	7,5	8,8	10
S	7	8	10	13	17	19	22	24

D	M18	M20	M22	M24	M27	M30	M33	M36
P ¹⁾	2,5	2,5	2,5	3	3	3,5	3,5	4
E	30,14	33,53	35,72	39,98	45,2	50,85	55,37	60,79
K	11,5	12,5	14	15	17	18,7	21	22,5
S	27	30	32	36	41	46	50	55

¹⁾ Gewindesteigung

VPE

L \ D	M4	M5	M6	M8	M10	M12	M14	M16	M18	M20	M22	M24	M27	M30	M33	M36
5	500	-	-	-	-	-	-	-	-	-	-	-	-	-	-	-
6	500	500	500	-	-	-	-	-	-	-	-	-	-	-	-	-
8	500	500	500	200	-	-	-	-	-	-	-	-	-	-	-	-
10	500	500	500	200	200	100	-	-	-	-	-	-	-	-	-	-
12	500	500	500	200	200	100	-	-	-	-	-	-	-	-	-	-
14	500	500	500	200	200	-	-	-	-	-	-	-	-	-	-	-
16	500	500	500	200	200	100	100	50	-	-	-	-	-	-	-	-
18	500	500	500	200	200	100	-	-	-	-	-	-	-	-	-	-
20	500	500	500	200	200	100	100	50	-	-	-	-	-	-	-	-
22	500	500	500	200	200	100	-	-	-	-	-	-	-	-	-	-
25	500	500	500	200	200	100	100	50	-	25	-	-	-	-	-	-
28	-	500	500	200	200	100	-	-	-	-	-	-	-	-	-	-
30	500	500	500	200	200	100	100	50	50	25	-	25	-	-	-	-
35	500	500	500	200	100	100	100	50	50	25	-	25	-	10	-	-

L \ D	M4	M5	M6	M8	M10	M12	M14	M16	M18	M20	M22	M24	M27	M30	M33	M36
40	500	200	200	200	100	100	100	50	50	25	25	25	–	10	–	–
45	500	200	200	200	100	100	50	50	50	25	25	25	–	10	–	–
50	500	200	200	200	100	100	50	50	50	25	25	25	–	10	–	10
55	–	200	200	200	100	100	50	50	25	25	25	25	10	10	–	10
60	200	200	200	200	100	100	50	50	25	25	25	25	10	10	10	10
65	200	200	200	200	100	50	50	25	25	25	25	25	10	10	–	10
70	200	200	200	200	100	50	50	25	25	25	25	25	10	10	10	10
75	–	200	200	200	100	50	50	25	25	25	–	25	10	10	–	10
80	–	200	200	200	100	50	50	25	25	25	25	25	10	10	10	5
85	–	–	200	200	100	50	–	25	–	25	–	25	10	10	–	5
90	–	200	200	200	100	50	50	25	25	25	25	25	10	10	10	5
100	–	200	200	100	100	50	50	25	25	25	10	10	10	10	10	5
110	–	–	200	100	50	50	25	25	–	25	–	10	10	10	10	5
120	–	–	200	100	50	50	50	25	25	25	10	10	10	10	10	5
130	–	–	–	100	50	50	25	25	–	25	–	10	10	10	10	5
140	–	–	–	100	50	50	25	25	–	25	–	10	10	10	10	5
150	–	–	–	100	50	50	25	25	–	25	–	10	10	10	–	5
160	–	–	–	100	50	25	25	25	–	10	–	10	–	10	–	5
170	–	–	–	–	50	25	–	25	–	10	–	10	–	10	–	5
180	–	–	–	–	50	25	25	25	–	10	–	10	–	10	–	5
190	–	–	–	–	–	25	–	25	–	10	–	10	–	10	–	5
200	–	–	–	–	50	25	–	25	–	10	–	10	–	10	–	5
220	–	–	–	–	–	–	–	25	–	10	–	10	–	10	–	5
240	–	–	–	–	–	–	–	25	–	10	–	10	–	10	–	5
260	–	–	–	–	–	–	–	25	–	10	–	10	–	10	–	5
300	–	–	–	–	–	–	–	25	–	10	–	10	–	10	–	5

Die handelsüblichen Größen sind durch Angabe der VPE gekennzeichnet.
 Lieferbar in Güte: 8.8, 10.9, Messing, Polyamid sowie Edelstahl A2 und Edelstahl A4





Maße in mm

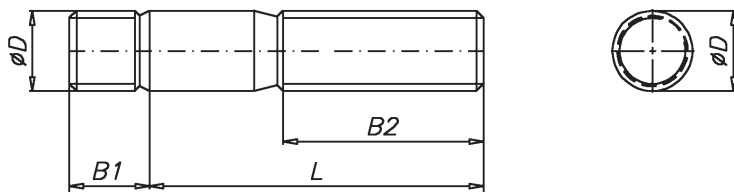

D	M6	M8	M10	M12	M16	M20	M24
P ¹⁾	1	1,25	1,5	1,75	2	2,5	3
B1	6	8	10	12	16	20	24
B2 ²⁾	18	22	26	30	38	46	54
B2 ³⁾	24	28	32	36	44	52	60
B2 ⁴⁾	-	-	45	49	57	65	73

Stiftschrauben nach dieser Norm werden vorwiegend zum Einschrauben in Stahl verwendet. Für das Gewinde am Einschraubende gilt nach DIN 267-2 das Toleranzfeld Sk 6 (Festsitzgewinde) nach DIN 13-51, wenn nicht in der Bezeichnung Fo (= ohne Festsitzgewinde) oder Sn 4 angegeben ist.

- ¹⁾ Gewindesteigung
- ²⁾ B2 für $L \leq 125$
- ³⁾ B2 für $125 < L \leq 200$
- ⁴⁾ B2 für $L > 200$

VPE

L \ D	M6	M8	M10	M12	M16	M20	M24
16	–	–	–	–	–	–	–
20	100	100	100	50	–	–	–
25	100	100	100	50	50	–	–
30	100	100	100	50	50	–	–
35	100	100	100	50	50	25	–
40	100	100	100	50	25	25	–
45	100	100	100	50	25	25	25
50	100	100	100	50	25	25	25
55	100	100	100	50	25	25	25
60	100	100	100	50	25	25	25
70	–	100	100	50	25	25	25
75	–	100	50	50	25	25	25
80	–	100	50	50	25	25	25
90	–	–	–	–	25	25	25
100	–	–	–	–	–	25	25

Die handelsüblichen Größen sind durch Angabe der VPE gekennzeichnet.
Lieferbar in Güte: 5.8 sowie A2 und A4





Maße in mm

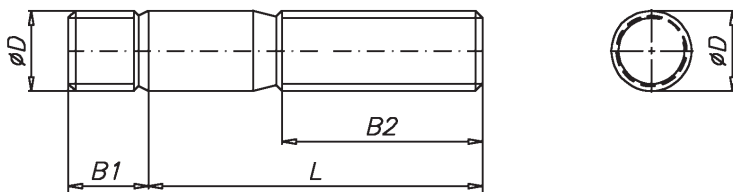

D	M6	M8	M10	M12	M16	M20	M24
P ¹⁾	1	1,25	1,5	1,75	2	2,5	3
B1	7,5	10	12	15	20	25	30
B2 ²⁾	18	22	26	30	38	46	54
B2 ³⁾	24	28	32	36	44	52	60
B2 ⁴⁾	-	-	45	49	57	65	73

Stiftschrauben nach dieser Norm werden vorwiegend zum Einschrauben in Gusseisen verwendet. Für das Gewinde am Einschraubende gilt nach DIN 267-2 das Toleranzfeld Sk 6 (Festsitzgewinde) nach DIN 13-51, wenn nicht in der Bezeichnung Fo (= ohne Festsitzgewinde) oder Sn 4 angegeben ist.

- ¹⁾ Gewindesteigung
- ²⁾ B2 für $L \leq 125$
- ³⁾ B2 für $125 < L \leq 200$
- ⁴⁾ B2 für $L > 200$

VPE

L \ D	M6	M8	M10	M12	M16	M20
16	100	100	–	–	–	–
20	100	100	100	–	–	–
25	100	100	100	50	–	–
30	100	100	100	50	50	–
35	100	100	100	50	50	–
40	100	100	100	50	25	25
45	100	100	100	50	25	25
50	100	100	100	50	25	25
55	100	100	100	50	25	25
60	100	100	100	50	25	25
70	–	100	100	50	25	25
80	–	100	50	50	25	25
90	–	100	50	50	25	25
100	–	100	50	50	25	25
120	–	–	–	50	25	25

Die handelsüblichen Größen sind durch Angabe der VPE gekennzeichnet.
Lieferbar in Güte: 5.8





Maße in mm

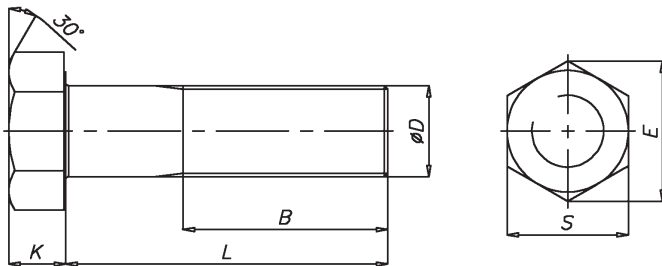

D	M8X1	M10X1	M12X1,5	M14X1,5	M16X1,5	M20X2
	-	M10X1,25	M12X1,25	-	-	M20X1,5
B ²⁾	22	26	30	34	38	46
B ³⁾	28	32	36	40	44	52
B ⁴⁾	-	45	49	53	57	65
E	14,38	18,9	21,1	24,49	26,75	33,53
K	5,3	6,4	7,5	8,8	10	12,5
S	13	17	19	22	24	30

Weitere Feingewindesteigungen auf Anfrage lieferbar.

²⁾ B für L ≤ 125

³⁾ B für 125 < L ≤ 200

⁴⁾ B für L > 200

VPE

L \ D	M8	M10	M12	M14	M16	M20
30	100	–	–	–	–	–
35	100	100	–	–	–	–
40	100	100	100	–	–	–
45	100	100	100	50	–	–
50	100	100	50	50	25	–
55	100	100	50	50	25	–
60	100	100	50	50	25	–
65	–	100	50	50	25	25
70	–	100	50	50	25	25
75	–	50	50	50	25	25
80	–	50	50	50	25	25
85	–	50	50	50	25	25
90	–	50	50	50	25	25
100	–	50	50	25	25	25
110	–	–	50	25	25	25
120	–	–	50	25	25	25
130	–	–	50	25	25	10
140	–	–	50	25	25	10
150	–	–	50	25	25	10
180	–	–	–	–	25	10
200	–	–	–	–	–	10

Die handelsüblichen Größen sind durch Angabe der VPE gekennzeichnet.
Lieferbar in Güte: 8.8, 10.9





Maße in mm

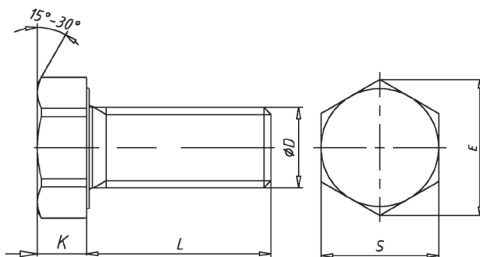

D	M8X1	M10X1	M12X1,5	M14X1,5	M16X1,5	M20X1,5
	-	M10X1,25	M12X1,25	-	-	M20X2
E	14,38	18,9	21,1	24,49	26,75	33,53
K	5,3	6,4	7,5	8,8	10	12,5
S	13	17	19	22	24	30

Weitere Feingewindesteigungen auf Anfrage lieferbar.

VPE

L \ D	M8	M10	M12	M14	M16	M20
10	200	–	–	–	–	–
12	200	–	–	–	–	–
16	200	200	200	–	–	–
20	200	200	200	100	50	–
25	200	200	200	100	50	–
30	200	200	200	100	50	25
35	200	200	100	100	50	25
40	200	200	100	100	50	25
45	200	200	100	100	50	25
50	200	200	100	100	50	25
55	–	200	100	100	50	25
60	–	200	100	50	50	25
65	–	200	100	50	50	25
70	–	200	100	50	50	25
80	–	–	100	50	50	25

Die handelsüblichen Größen sind durch Angabe der VPE gekennzeichnet.
Lieferbar in Güte: 8.8, 10.9





Maße in mm

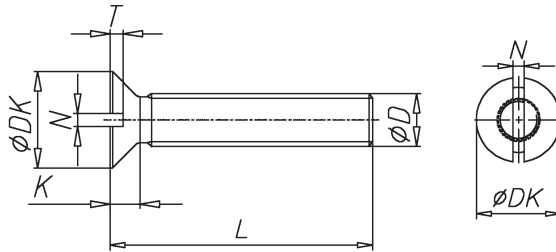

D	M2	M2,5	M3	M3,5	M4	M5	M6	M8	M10	M12
P ¹⁾	0,4	0,45	0,5	0,6	0,7	0,8	1	1,25	1,5	1,75
DK	3,8	4,7	5,6	6,5	7,5	9,2	11	14,5	18	22
K	1,2	1,5	1,65	1,93	2,2	2,5	3	4	5	6
N	0,5	0,6	0,8	0,8	1	1,2	1,6	2	2,5	3
T min	0,4	0,5	0,6	0,7	0,8	1	1,2	1,6	2	2,4

¹⁾ Gewindesteigung

VPE

L \ D	M2	M2,5	M3	M3,5	M4	M5	M6	M8	M10	M12
4	1000	1000	1000	–	–	–	–	–	–	–
5	1000	1000	1000	–	1000	–	–	–	–	–
6	1000	1000	1000	1000	1000	500	–	–	–	–
8	1000	1000	1000	1000	1000	500	200	–	–	–
10	1000	1000	1000	1000	1000	200	200	100	–	–
12	1000	1000	1000	1000	500	200	200	100	–	–
14	1000	1000	1000	–	500	200	200	100	–	–
16	1000	1000	1000	1000	500	200	200	100	100	–
18	1000	1000	1000	–	500	200	200	100	100	–
20	1000	1000	1000	1000	200	200	200	100	100	100
25	1000	1000	1000	500	200	200	200	100	100	100
30	–	1000	500	500	200	200	200	100	100	100
35	–	–	500	–	200	200	200	100	100	100
40	–	–	500	–	200	200	200	100	100	100
45	–	–	500	–	200	200	200	100	100	100
50	–	–	500	–	200	200	200	100	100	100
55	–	–	–	–	200	200	200	100	–	–
60	–	–	–	–	200	200	200	100	100	100
65	–	–	–	–	–	200	200	100	100	–
70	–	–	–	–	–	200	200	100	100	100
80	–	–	–	–	–	200	200	100	100	100
90	–	–	–	–	–	200	200	100	100	100
100	–	–	–	–	–	200	200	100	100	100

Die handelsüblichen Größen sind durch Angabe der VPE gekennzeichnet.
Lieferbar in Güte: 4.8, Messing, Polyamid sowie Edelstahl A2 und Edelstahl A4





Maße in mm

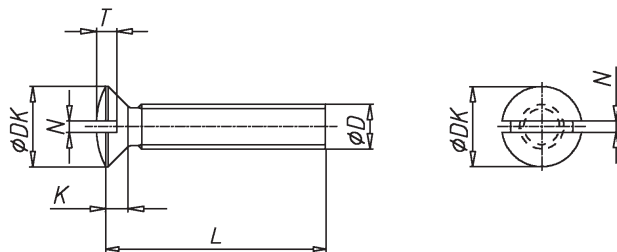

D	M2	M2,5	M3	M4	M5	M6	M8	M10
P ¹⁾	0,4	0,45	0,5	0,7	0,8	1	1,25	1,5
DK	3,8	4,7	5,6	7,5	9,2	11	14,5	18
K	1,2	1,5	1,65	2,2	2,5	3	4	5
N	0,5	0,6	0,8	1	1,2	1,6	2	2,5
T min	0,8	1	1,2	1,6	2	2,4	3,2	4

¹⁾ Gewindesteigung

VPE

L \ D	M2	M2,5	M3	M4	M5	M6	M8
4	200	–	–	–	–	–	–
5	200	200	200	200	–	–	–
6	200	200	200	200	–	–	–
8	200	200	200	200	200	–	–
10	–	200	200	200	200	200	–
12	–	200	200	200	200	200	100
14	–	–	200	200	–	–	–
16	–	200	200	200	200	200	100
18	–	–	–	200	200	200	–
20	–	–	200	200	200	200	100
25	–	–	200	200	200	200	100
30	–	–	200	200	200	200	100
35	–	–	200	200	200	200	100
40	–	–	200	200	200	200	100
45	–	–	200	200	200	200	–
50	–	–	200	200	200	200	100
60	–	–	–	200	200	200	100
70	–	–	–	–	–	200	100
80	–	–	–	–	100	100	100
100	–	–	–	–	–	100	100

Die handelsüblichen Größen sind durch Angabe der VPE gekennzeichnet.
Lieferbar in Güte: 4.8, Messing, Polyamid sowie Edelstahl A2 und Edelstahl A4





Maße in mm

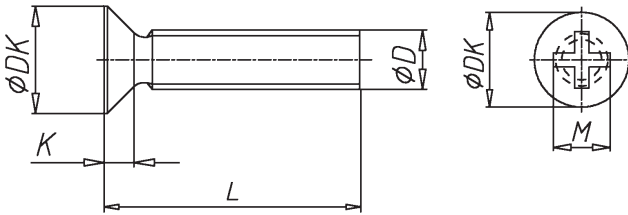

D	M2	M2,5	M3	M4	M5	M6	M8	M10
P ¹⁾	0,4	0,45	0,5	0,7	0,8	1	1,25	1,5
DK	3,8	4,7	5,6	7,5	9,2	11	14,5	18
K	1,2	1,5	1,65	2,2	2,5	3	4	5
M	2,35	2,7	2,9	4,4	4,6	6,6	8,7	9,6

¹⁾ Gewindesteigung

VPE

L \ D	M2	M2,5	M3	M4	M5	M6	M8	M10
4	1000	1000	1000	–	–	–	–	–
5	1000	1000	1000	500	–	–	–	–
6	1000	1000	1000	500	500	–	–	–
8	1000	1000	1000	500	500	500	–	–
10	1000	1000	1000	500	500	200	–	–
12	1000	1000	1000	500	500	200	200	–
14	–	–	1000	500	500	200	–	–
16	1000	1000	1000	500	500	200	200	–
18	–	–	1000	500	500	–	200	–
20	1000	1000	500	500	200	200	200	100
22	–	–	500	500	200	200	–	–
25	–	–	500	200	200	200	100	100
30	–	–	500	200	200	200	100	100
35	–	–	500	200	200	200	100	100
40	–	–	500	200	200	200	100	100
45	–	–	–	200	200	200	100	100
50	–	–	500	200	200	200	100	100
55	–	–	–	200	200	200	–	–
60	–	–	500	200	200	200	100	100
65	–	–	–	200	200	200	–	–
70	–	–	–	200	200	200	100	100
80	–	–	–	200	200	200	100	100
90	–	–	–	200	200	200	100	100
100	–	–	–	–	200	200	100	100

Die handelsüblichen Größen sind durch Angabe der VPE gekennzeichnet.
Lieferbar in Güte: 4.8 sowie Edelstahl A2





Maße in mm

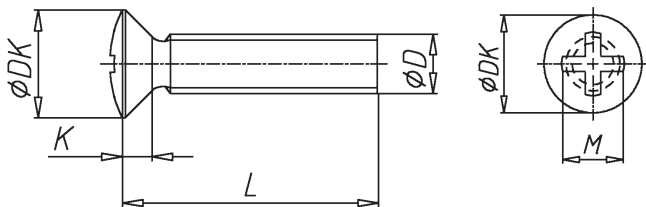

D	M2,5	M3	M4	M5	M6	M8
P ¹⁾	0,45	0,5	0,7	0,8	1	1,25
DK	4,7	5,6	7,5	9,2	11	14,5
K	1,5	1,65	2,2	2,5	3	4
M	2,7	3,1	4,5	5,3	6,8	9

¹⁾ Gewindesteigung

VPE

L \ D	M2,5	M3	M4	M5	M6	M8
5	1000	1000	–	–	–	–
6	1000	1000	500	–	–	–
8	1000	1000	500	500	–	–
10	1000	1000	500	500	200	–
12	1000	500	500	500	200	–
16	1000	500	500	200	200	200
20	1000	500	500	200	200	200
25	–	500	500	200	200	200
30	–	500	200	200	200	200
35	–	500	200	200	200	–
40	–	500	200	200	200	200
45	–	–	200	200	200	–
50	–	–	200	200	200	200
55	–	–	–	200	200	200
60	–	–	200	200	200	200

Die handelsüblichen Größen sind durch Angabe der VPE gekennzeichnet.
 Lieferbar in Güte: 4.8 sowie Edelstahl A2





Maße in mm

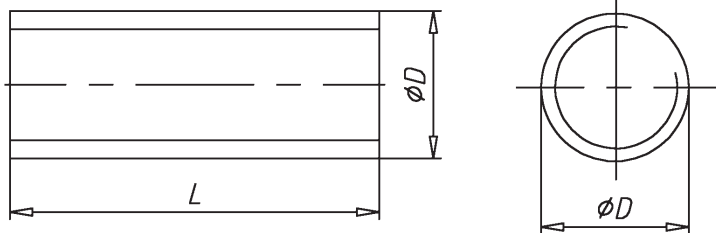

D	M2	M2,5	M3	M4	M5	M6	M8	M10	M12	M14
P ¹⁾	0,4	0,45	0,5	0,7	0,8	1	1,25	1,5	1,75	2

D	M16	M18	M20	M22	M24	M27	M30	M33	M36	M39
P ¹⁾	2	2,5	2,5	2,5	3	3	3,5	3,5	4	4

Auch mit Feingewinde, Linksgewinde, Zollgewinde oder Trapezgewinde lieferbar.

¹⁾ Gewindesteigung

VPE

L \ D	M2	M2,5	M3	M4	M5	M6	M8	M10	M12	M14	M16	M18	M20	M22	M24	M27	M30	M33	M36	M39
1000	1	1	1	1	1	1	1	1	1	1	1	1	1	1	1	1	1	1	1	1
2000	-	-	-	-	1	1	1	1	1	-	1	-	1	-	1	-	1	-	-	-
3000	-	-	-	-	-	-	-	-	1	-	1	-	1	-	1	-	1	-	-	-

Die handelsüblichen Größen sind durch Angabe der VPE gekennzeichnet.

Lieferbar in Stahl, Güte: 4.8, 8.8, 10.9, 12.9, Aluminium, Polyamid sowie Edelstahl A2 und Edelstahl A4

Farben zur Kennzeichnung von Gewindebolzen

Stahl	Farbe	Farbe entsprechend RAL
Festigkeitsklasse 4.8	keine Kennzeichnung	
Festigkeitsklasse 5.6	Kastanienbraun	RAL 8015
Festigkeitsklasse 5.8	Enzianblau	RAL 5010
Festigkeitsklasse 8.8	Verkehrsgelb	RAL 1023
Festigkeitsklasse 10.9	Perlweiß	RAL 1013
Festigkeitsklasse 12.9	Verkehrsschwarz	RAL 9017
Nichtrostend A2	Verkehrsgrün	RAL 6024
Nichtrostend A4	Feuerrot	RAL 3000

1



2



3



4



5



6



7



8



9





Maße in mm

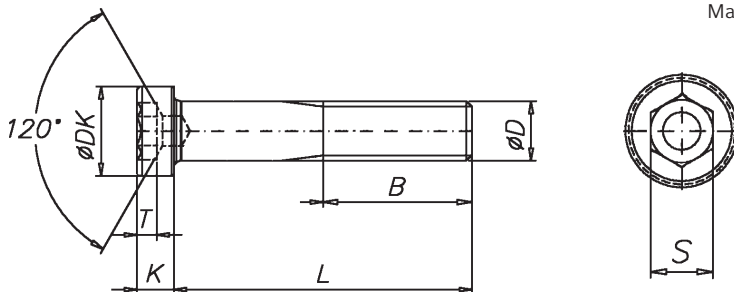

D	M4	M5	M6	M8	M10	M12	M14	M16	M20	M24
P ¹⁾	0,7	0,8	1	1,25	1,5	1,75	2	2	2,5	3
B ²⁾	14	16	18	22	26	30	34	38	46	54
B ³⁾	-	-	-	-	32	36	40	44	52	60
B ⁴⁾	-	-	-	-	-	-	-	57	65	73
DK	7	8,5	10	13	16	18	21	24	30	36
K	2,8	3,5	4	5	6,5	7,5	8,5	10	12	14
S	3	4	5	6	8	10	12	14	17	19
T	1,6	2	2,5	3	3,5	4	4,5	5,5	6,5	7

¹⁾ Gewindesteigung

²⁾ B für L ≤ 125

³⁾ B für 125 < L ≤ 200

⁴⁾ B für L > 200

Bei kurzen Abmessungen ist fertigungsbedingt ein Schaft von ≈ 5 P vorhanden.

VPE

L \ D	M4	M5	M6	M8	M10	M12	M14	M16	M20	M24
6	500	500	–	–	–	–	–	–	–	–
8	500	500	500	–	–	–	–	–	–	–
10	500	500	500	200	–	–	–	–	–	–
12	500	500	500	200	200	–	–	–	–	–
14	500	500	500	200	–	–	–	–	–	–
16	500	500	500	200	200	100	–	–	–	–
18	500	500	500	200	200	–	–	–	–	–
20	500	500	200	200	200	100	–	50	–	–
25	500	200	200	200	200	100	100	50	–	–
30	500	200	200	200	200	100	100	50	25	–
35	500	200	200	200	100	100	100	50	25	–
40	200	200	200	200	100	100	50	50	25	–
45	200	200	200	200	100	100	50	50	25	25
50	200	200	200	200	100	100	50	50	25	25
55	–	200	200	200	100	100	–	50	25	25
60	–	200	200	200	100	100	50	50	25	25
65	–	–	200	200	100	100	–	50	25	–
70	–	200	200	200	100	100	50	25	25	25
75	–	–	200	200	100	100	–	25	25	–
80	–	200	200	200	100	100	50	25	25	25
90	–	–	200	200	100	100	50	25	25	25
100	–	–	200	100	100	50	50	25	25	25
110	–	–	200	100	100	50	–	25	25	–
120	–	–	200	100	100	50	–	25	25	25
130	–	–	–	100	50	50	–	25	25	–
140	–	–	–	100	50	50	–	25	25	–
150	–	–	–	100	50	50	–	25	25	–
160	–	–	–	–	–	–	–	25	25	–
180	–	–	–	–	–	–	–	25	25	–
200	–	–	–	–	–	–	–	25	25	–

Die handelsüblichen Größen sind durch Angabe der VPE gekennzeichnet.
Lieferbar in Güte: 8.8, 10.9 sowie Edelstahl A2 und Edelstahl A4



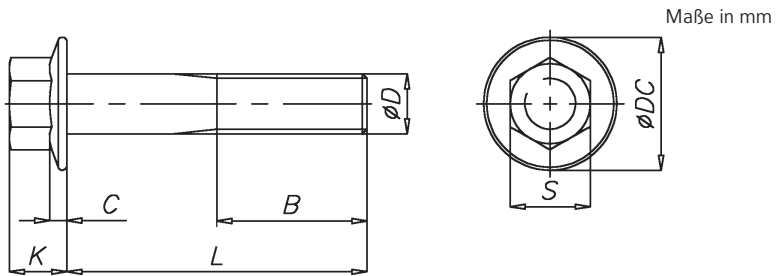

D	M6	M8	M10	M12	M16
P ¹⁾	1	1,25	1,5	1,75	2
B ²⁾	18	22	26	30	38
B ³⁾	-	28	32	36	44
B ⁴⁾	-	-	-	-	57
C	1,1	1,2	1,5	1,8	2,4
DC	14,2	18	22,3	26,6	35
K	6,6	8,1	9,2	11,5	14,4
S	10	13	15	16	21

¹⁾ Gewindesteigung
²⁾ B für L ≤ 125
³⁾ B für 125 < L ≤ 200
⁴⁾ B für L > 200

VPE

L \ D	M6	M8	M10	M12	M16
12	500	-	-	-	-
16	500	-	-	-	-
20	500	200	-	-	-
25	500	200	200	200	-
30	-	200	200	200	-
35	-	200	200	200	50
40	-	200	200	200	50
50	-	200	200	100	50
60	-	-	200	100	50
70	-	-	-	100	50
80	-	-	-	-	50

Die handelsüblichen Größen sind durch Angabe der VPE gekennzeichnet.
 Lieferbar in Güte: 8.8, 10.9, 12.9 sowie Edelstahl A2

Maße in mm

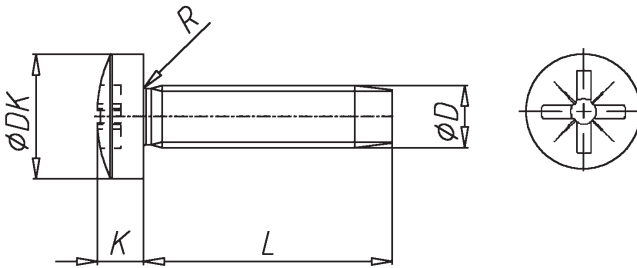

D	M2,5	M3	M4	M5	M6
P ¹⁾	0,45	0,5	0,7	0,8	1
DK	5	6	8	10	12
K	2	2,4	3,1	3,8	4,6

übrige Maße nach DIN 7985

¹⁾ Gewindesteigung

VPE

L \ D	M2,5	M3	M4	M5	M6
5	–	1000	–	–	–
6	1000	1000	1000	–	–
8	1000	1000	1000	–	–
10	1000	1000	1000	1000	1000
12	1000	1000	1000	1000	1000
16	–	1000	1000	1000	1000
20	–	1000	1000	1000	1000
25	–	1000	1000	1000	1000
30	–	1000	1000	1000	1000
35	–	–	–	–	1000
40	–	–	–	–	1000
50	–	–	–	–	1000

Die handelsüblichen Größen sind durch Angabe der VPE gekennzeichnet.
Lieferbar in Stahl





Maße in mm

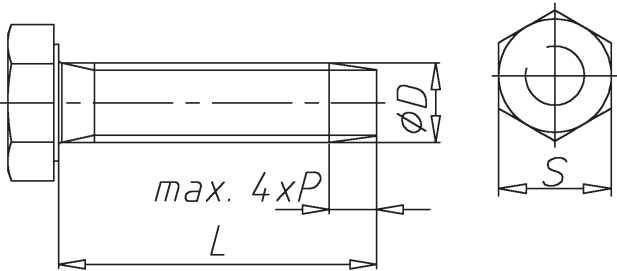

D	M4	M5	M6	M8
P ¹⁾	0,7	0,8	1	1,25
S	7	8	10	13

übrige Maße nach DIN 933
¹⁾ Gewindesteigung

VPE

L \ D	M4	M5	M6	M8
6	1000	-	-	-
8	1000	-	-	-
10	1000	1000	500	-
12	1000	1000	500	200
16	1000	1000	500	200
20	1000	1000	500	200
25	1000	1000	500	200
30	-	1000	500	200
35	-	1000	500	200
40	-	1000	500	200
45	-	-	500	200
50	-	-	500	200
60	-	-	-	200

Die handelsüblichen Größen sind durch Angabe der VPE gekennzeichnet.
 Lieferbar in Stahl

Maße in mm

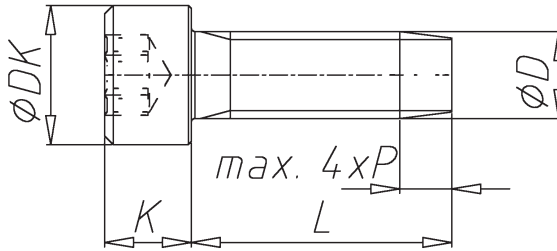

D	M4	M5	M6	M8
P ¹⁾	0,7	0,8	1	1,25
DK	7	8,5	10	13
K	4	5	6	8

übrige Maße nach DIN 912

¹⁾ Gewindesteigung

VPE

L \ D	M4	M5	M6	M8
8	–	500	–	–
10	1000	500	–	–
12	1000	500	500	–
16	1000	500	500	100
20	500	500	500	100
25	500	500	500	100
30	500	500	500	100
40	–	500	500	100
50	–	–	500	100
60	–	–	–	100

Die handelsüblichen Größen sind durch Angabe der VPE gekennzeichnet.
Lieferbar in Stahl





Maße in mm

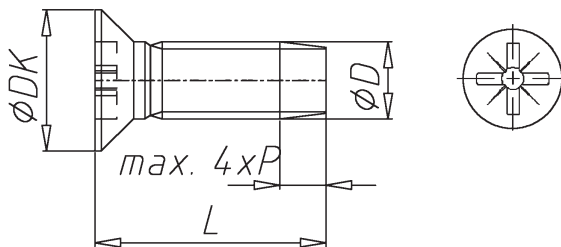

D	M3	M4	M5	M6	M8
P ¹⁾	0,5	0,7	0,8	1	1,25
DK	5,6	7,5	9,2	11	14,5

übrige Maße nach EN ISO 7046

¹⁾ Gewindesteigung

VPE

L \ D	M3	M4	M5	M6	M8
6	1000	1000	–	–	–
8	1000	1000	–	–	–
10	1000	1000	1000	–	–
12	1000	1000	1000	1000	–
16	1000	1000	1000	1000	500
20	1000	1000	1000	1000	500
25	1000	1000	1000	1000	500
30	–	1000	1000	1000	500
35	–	–	1000	1000	500
40	–	–	1000	1000	500

Die handelsüblichen Größen sind durch Angabe der VPE gekennzeichnet.
Lieferbar in Stahl

Maße in mm

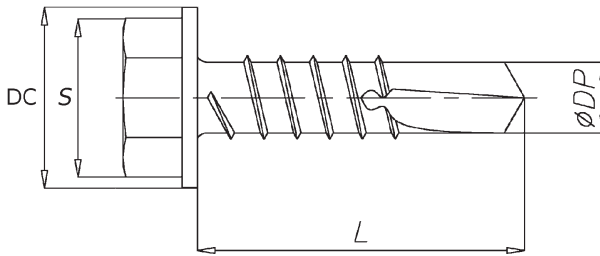

D	3,5	3,9	4,2	4,8	5,5	6,3
DP	2,8	3,1	3,6	4,1	4,8	5,8
DC	8,3	8,3	8,8	10,5	11	13,2
S	5,5	5,5	7	8	8	10
BB min ¹⁾	0,7	0,7	1,75	1,75	1,75	2
BB max ²⁾	2,25	2,4	3	4,4	5,25	6

Die Härte des Blechmaterials sollte 135 HB nicht überschreiten. Bei einer Unterschreitung der Blechdicke können Deformationen durch den Anpressdruck, oder Überdrehung entstehen. Angegebener Bohrbereich gilt nur bei der Verwendung von Bohrschrauben aus dem Werkstoff Stahl.

¹⁾ Bohrbereich von

²⁾ Bohrbereich bis

VPE

L \ D	3,5	3,9	4,2	4,8	5,5	6,3
13	1000	1000	1000	500	–	–
16	1000	1000	1000	500	500	500
19	1000	1000	1000	500	500	500
22	1000	1000	1000	500	500	500
25	–	1000	1000	500	500	500
32	–	–	1000	500	500	500
38	–	–	–	500	250	500
45	–	–	–	500	250	250
50	–	–	–	500	250	250
60	–	–	–	–	–	250
70	–	–	–	–	–	250

Die handelsüblichen Größen sind durch Angabe der VPE gekennzeichnet.
Lieferbar in Stahl sowie Edelstahl A2



Maße in mm

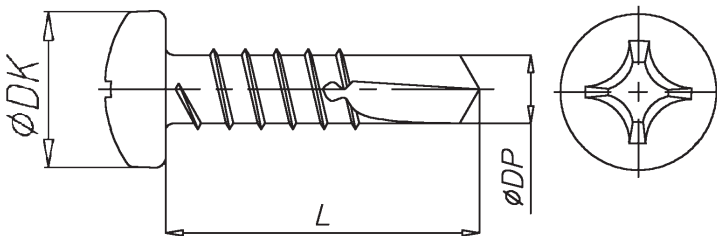

D	2,9	3,9	4,2	4,8	5,5	6,3
DP	2,3	3,1	3,6	4,1	4,8	5,8
DK	5,6	7,5	8,2	9,5	10,8	12,5
BB min ¹⁾	0,7	0,7	1,75	1,75	1,75	2
BB max ²⁾	1,9	2,4	3	4,4	5,25	6

Die Härte des Blechmaterials sollte 135 HB nicht überschreiten. Bei einer Unterschreitung der Blechdicke können Deformationen durch den Anpressdruck, oder Überdrehung entstehen. Angegebener Bohrbereich gilt nur bei der Verwendung von Bohrschrauben aus dem Werkstoff Stahl.

Übrige Maße nach DIN 7981

¹⁾ Bohrbereich von

²⁾ Bohrbereich bis

VPE

L \ D	2,9	3,5	3,9	4,2	4,8	5,5	6,3
9,5	1000	1000	–	–	–	–	–
13	1000	1000	1000	1000	500	–	–
16	1000	1000	1000	1000	500	–	–
19	1000	1000	1000	1000	500	500	500
22	–	1000	1000	1000	500	500	500
25	–	1000	1000	1000	500	500	500
32	–	1000	1000	1000	500	500	250
38	–	–	1000	1000	500	250	250
45	–	–	–	1000	500	250	250
50	–	–	–	500	500	–	250
60	–	–	–	–	500	–	–
80	–	–	–	–	250	–	–

Die handelsüblichen Größen sind durch Angabe der VPE gekennzeichnet.
Lieferbar in Stahl sowie Edelstahl A2



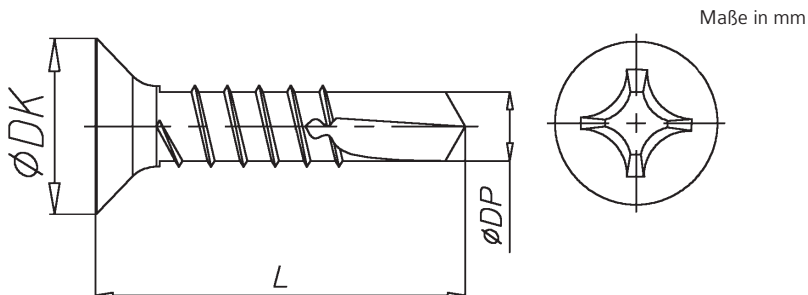

D	3,5	3,9	4,2	4,8	5,5	6,3
DP	2,8	3,1	3,6	4,1	4,8	5,8
DK	6,8	7,5	8,1	9,5	10,8	12,4
BB min ¹⁾	0,7	0,7	1,75	1,75	1,75	2
BB max ²⁾	2,25	2,4	3	4,4	5,25	6

Die Härte des Blechmaterials sollte 135 HB nicht überschreiten. Bei einer Unterschreitung der Blechdicke können Deformationen durch den Anpressdruck, oder Überdrehung entstehen. Angegebener Bohrbereich gilt nur bei der Verwendung von Bohrschrauben aus dem Werkstoff Stahl.

Übrige Maße nach DIN 7982

¹⁾ Bohrbereich von

²⁾ Bohrbereich bis

VPE

L \ D	3,5	3,9	4,2	4,8	5,5	6,3
13	1000	1000	1000	–	–	–
16	1000	1000	1000	500	–	–
19	1000	1000	1000	500	–	–
22	1000	1000	1000	500	–	–
25	1000	1000	1000	500	500	500
32	–	1000	1000	500	500	500
38	–	1000	1000	500	250	500
45	–	1000	1000	500	250	250
50	–	–	–	500	250	250
60	–	–	–	500	250	250
70	–	–	–	250	250	250
80	–	–	–	–	–	250

Die handelsüblichen Größen sind durch Angabe der VPE gekennzeichnet.

Lieferbar in Stahl sowie Edelstahl A2

Maße in mm

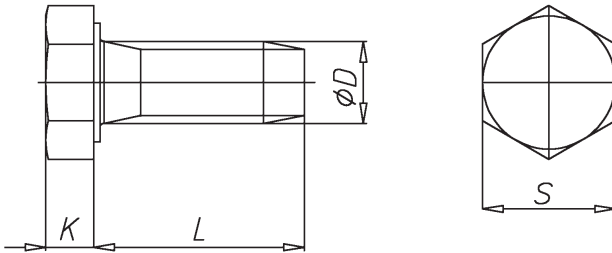

D	M4	M5	M6	M8
K	2,8	3,5	4	5,3
S	7	8	10	13
DH ¹⁾	3,6	4,5	5,5	7,4

¹⁾ Kernlochdurchmesser für Bohrungen in Werkstoffe aus mittlerer Festigkeit. Die Einschraubtiefe sollte nicht größer 2 x D sein. Übrige Maße nach DIN 933

VPE

L \ D	M4	M5	M6	M8
10	1000	500	–	–
12	1000	500	200	–
16	1000	500	200	100
20	1000	500	200	100
25	1000	500	200	100
30	500	500	200	100
35	–	–	100	100
40	–	–	–	100
50	–	–	–	100

Die handelsüblichen Größen sind durch Angabe der VPE gekennzeichnet.
Lieferbar in Stahl





Maße in mm

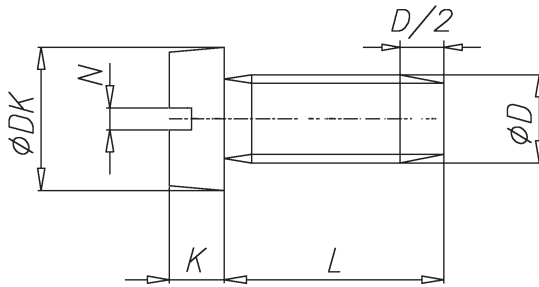

D	M2,5	M3	M4	M5	M6
DK	4,5	5,5	7	8,5	10
N	0,6	0,8	1,2	1,2	1,6
K	1,6	2	2,6	3,3	3,9
DH ¹⁾	2,2	2,7	3,6	4,5	5,5

¹⁾ Kernlochdurchmesser für Bohrungen in Werkstoffe aus mittlerer Festigkeit. Die Einschraubtiefe sollte nicht größer 2 x D sein. Übrige Maße nach DIN 84

VPE

L \ D	M2,5	M3	M4	M5	M6
6	1000	1000	1000	–	–
8	1000	1000	1000	–	–
10	1000	1000	1000	500	–
12	1000	1000	1000	500	200
16	1000	1000	1000	500	200
20	–	1000	1000	500	200
25	–	–	1000	500	200
30	–	–	–	–	200

Die handelsüblichen Größen sind durch Angabe der VPE gekennzeichnet. Lieferbar in Stahl

Maße in mm

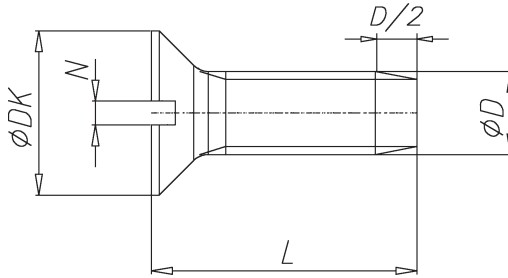

D	M4	M5	M6	M8
DK	7,5	9,2	11	14,5
N	1	1,2	1,6	2
DH ¹⁾	3,6	4,5	5,5	7,4

¹⁾ Kernlochdurchmesser für Bohrungen in Werkstoffe aus mittlerer Festigkeit. Die Einschraubtiefe sollte nicht größer 2 x D sein. Übrige Maße nach DIN 963

VPE

L \ D	M4	M5	M6	M8
8	1000	–	–	–
10	1000	500	–	–
12	1000	500	200	–
16	500	500	200	100
20	500	500	200	100
25	500	500	200	100
30	–	500	200	100
35	–	–	100	100
40	–	–	100	100
50	–	–	100	100
60	–	–	100	–

Die handelsüblichen Größen sind durch Angabe der VPE gekennzeichnet.
Lieferbar in Stahl



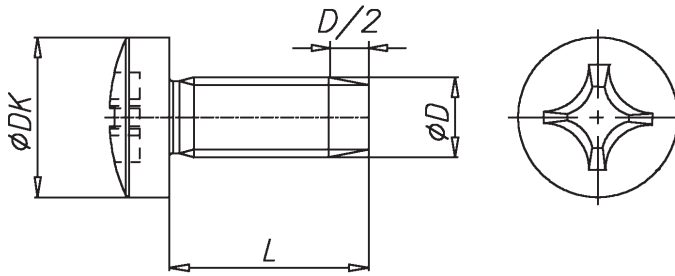

Maße in mm

D	M3	M4	M5	M6	M8
DK	6	8	10	12	16
DH ¹⁾	2,7	3,6	4,5	5,5	7,4

¹⁾ Kernlochdurchmesser für Bohrungen in Werkstoffe aus mittlerer Festigkeit. Die Einschraubtiefe sollte nicht größer 2 x D sein. Übrige Maße nach DIN 7985

VPE

L \ D	M3	M4	M5	M6	M8
6	1000	1000	–	–	–
8	1000	1000	–	–	–
10	1000	1000	500	–	–
12	1000	1000	500	200	–
16	1000	1000	500	200	100
20	1000	1000	500	200	100
25	1000	500	500	200	100
30	–	500	500	100	100
40	–	500	500	100	100
50	–	–	–	–	100

Die handelsüblichen Größen sind durch Angabe der VPE gekennzeichnet.
Lieferbar in Stahl

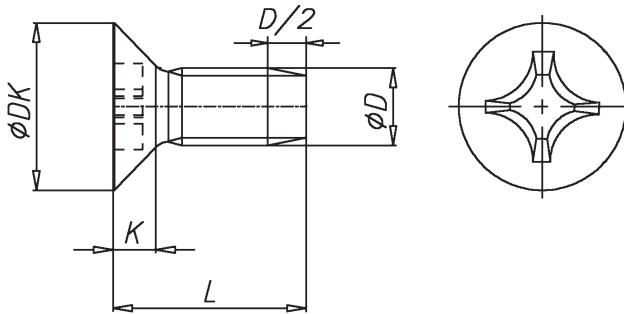

Maße in mm

D	M3	M4	M5	M6	M8
DK	5,6	7,5	9,2	11	14,5
K	1,65	2,2	2,5	3	4
DH ¹⁾	2,7	3,6	4,5	5,5	7,4

¹⁾ Kernlochdurchmesser für Bohrungen in Werkstoffe aus mittlerer Festigkeit. Die Einschraubtiefe sollte nicht größer 2 x D sein. Übrige Maße nach DIN 965

VPE

L \ D	M3	M4	M5	M6	M8
6	1000	–	–	–	–
8	–	1000	–	–	–
10	1000	1000	–	–	–
12	1000	1000	500	200	–
16	1000	1000	500	200	100
20	1000	1000	500	200	100
25	1000	1000	500	200	100
30	–	1000	500	200	100
35	–	–	200	100	100
40	–	–	200	100	100
50	–	–	–	100	100

Die handelsüblichen Größen sind durch Angabe der VPE gekennzeichnet.
Lieferbar in Stahl





Maße in mm

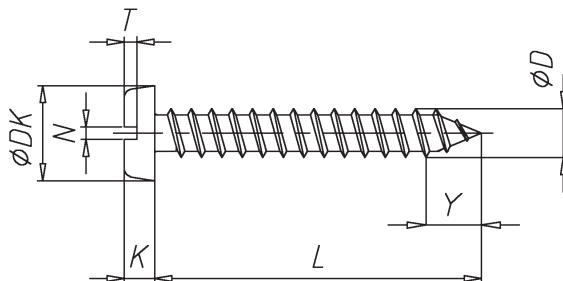

D	2,2	2,9	3,5	3,9	4,2	4,8	5,5	6,3
DK	4,2	5,6	6,9	7,5	8,2	9,5	10,8	12,5
N	0,6	0,8	1	1	1,2	1,2	1,6	1,6
K	1,35	1,75	2,1	2,25	2,45	2,8	3,2	3,65
T min	0,55	0,75	0,95	1,05	1,15	1,35	1,55	1,8
Y	2	2,6	3,2	3,5	3,7	4,3	5	6

VPE

L \ D	2,2	2,9	3,5	3,9	4,2	4,8	5,5	6,3
4,5	1000	1000	–	–	–	–	–	–
6,5	1000	1000	1000	1000	–	–	–	–
9,5	1000	1000	1000	1000	1000	1000	–	–
13	1000	1000	1000	1000	1000	1000	500	500
16	1000	1000	1000	1000	1000	1000	500	500
19	1000	1000	1000	1000	1000	1000	500	500
22	–	1000	1000	1000	1000	1000	500	500
25	–	1000	1000	1000	1000	500	500	500
32	–	1000	1000	500	500	500	250	250
38	–	–	1000	500	500	250	250	250
45	–	–	–	–	500	250	250	250
50	–	–	–	–	500	250	250	250
60	–	–	–	–	–	250	–	–
70	–	–	–	–	–	250	–	–

Die handelsüblichen Größen sind durch Angabe der VPE gekennzeichnet.
Lieferbar in Stahl sowie Edelstahl A2

Maße in mm

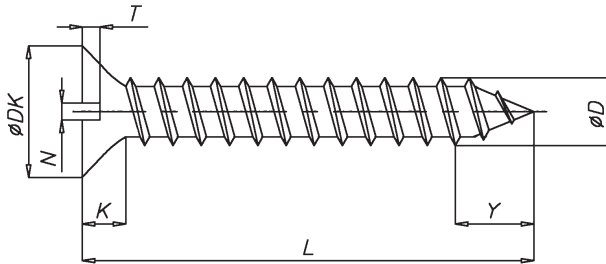

D	2,2	2,9	3,5	3,9	4,2	4,8	5,5	6,3
DK	4,3	5,5	6,8	7,5	8,1	9,5	10,8	12,4
N	0,6	0,8	1	1	1,2	1,2	1,6	1,6
K	1,3	1,7	2,1	2,3	2,5	3	3,4	3,8
T min	0,4	0,5	0,6	0,7	0,75	0,85	1	1,2
Y	2	2,6	3,2	3,5	3,7	4,3	5	6

VPE

L \ D	2,2	2,9	3,5	3,9	4,2	4,8	5,5	6,3
6,5	1000	1000	–	–	–	–	–	–
9,5	1000	1000	1000	1000	1000	1000	–	–
13	1000	1000	1000	1000	1000	1000	–	–
16	–	1000	1000	1000	1000	1000	–	500
19	–	1000	1000	1000	1000	1000	500	500
22	–	1000	1000	1000	1000	1000	500	500
25	–	1000	1000	1000	1000	500	500	500
32	–	–	–	500	500	500	250	250
38	–	–	–	500	500	250	250	250
45	–	–	–	–	500	250	250	250
50	–	–	–	–	500	250	250	250
60	–	–	–	–	500	250	–	–

Die handelsüblichen Größen sind durch Angabe der VPE gekennzeichnet.
Lieferbar in Stahl sowie Edelstahl A2

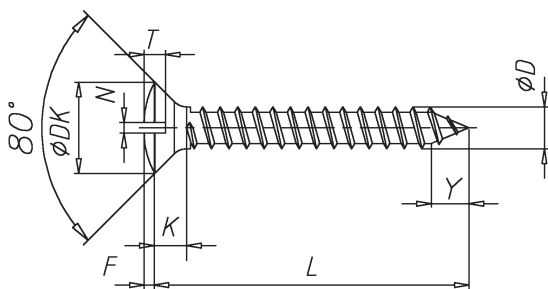

Maße in mm

D	2,2	2,9	3,5	3,9	4,2	4,8	5,5	6,3
DK	4,3	5,5	6,8	7,5	8,1	9,5	10,8	12,4
F	0,7	0,9	1,2	1,3	1,4	1,5	1,7	2
N	0,6	0,8	1	1	1,2	1,2	1,6	1,6
K	1,3	1,7	2,1	2,3	2,5	3	3,4	3,8
T min	0,95	1,25	1,55	1,7	1,85	2,15	2,45	2,85
Y	2	2,6	3,2	3,5	3,7	4,3	5	6

VPE

L \ D	2,2	2,9	3,5	3,9	4,2	4,8	6,3
6,5	1000	1000	–	–	–	–	–
9,5	1000	1000	1000	–	–	–	–
13	1000	1000	1000	1000	1000	1000	–
16	1000	1000	1000	1000	1000	1000	500
19	–	1000	1000	1000	1000	1000	500
22	–	1000	1000	1000	1000	1000	500
25	–	1000	1000	1000	1000	1000	500
32	–	–	1000	1000	1000	500	250
38	–	–	1000	1000	500	500	250
45	–	–	–	–	–	250	–
50	–	–	–	–	–	250	–

Die handelsüblichen Größen sind durch Angabe der VPE gekennzeichnet.
Lieferbar in Stahl sowie Edelstahl A2

Maße in mm

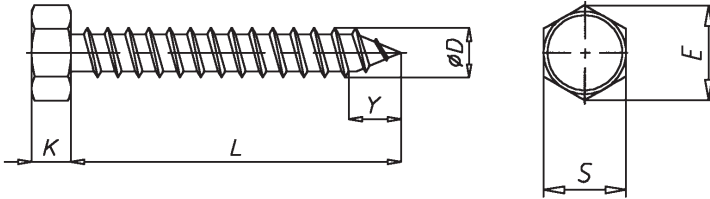

D	2,9	3,5	4,2	4,8	5,5	6,3	8
E	5,4	5,96	7,59	8,71	8,71	10,95	14,26
K	1,5	2,3	2,8	3	4	4,8	5,8
S	5	5,5	7	8	8	10	13
Y	2,6	3,2	3,7	4,3	5	6	7,5

VPE

L \ D	2,9	3,5	3,9	4,2	4,8	5,5	6,3	8
6,5	1000	–	–	–	–	–	–	–
9,5	1000	1000	1000	1000	1000	–	–	–
13	1000	1000	1000	1000	1000	500	500	–
16	–	1000	1000	1000	1000	500	500	250
19	–	1000	1000	1000	1000	500	500	250
22	–	–	1000	1000	1000	500	500	250
25	–	–	1000	1000	500	500	500	250
32	–	–	–	500	500	250	250	250
38	–	–	–	–	250	250	250	250
45	–	–	–	–	–	250	250	–
50	–	–	–	–	–	250	250	250
60	–	–	–	–	–	–	250	–
70	–	–	–	–	–	–	250	–
80	–	–	–	–	–	–	250	–

Die handelsüblichen Größen sind durch Angabe der VPE gekennzeichnet.
Lieferbar in Stahl sowie Edelstahl A2



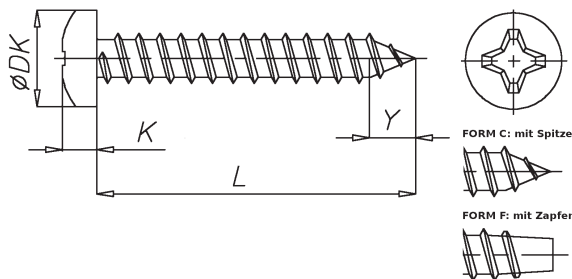

Maße in mm

D	2,2	2,9	3,5	3,9	4,2	4,8	5,5	6,3
DK	4,2	5,6	6,9	7,5	8,2	9,5	10,8	12,5
K	1,8	2,2	2,6	2,8	3,05	3,55	3,95	4,55
Y	2	2,6	3,2	3,5	3,7	4,3	5	6

VPE

L \ D	2,2	2,9	3,5	3,9	4,2	4,8	5,5	6,3
4,5	1000	1000	–	–	–	–	–	–
6,5	1000	1000	1000	1000	1000	–	–	–
9,5	1000	1000	1000	1000	1000	1000	–	–
13	1000	1000	1000	1000	1000	1000	500	500
16	1000	1000	1000	1000	1000	1000	500	500
19	1000	1000	1000	1000	1000	1000	500	500
22	–	1000	1000	1000	1000	1000	500	500
25	–	1000	1000	1000	1000	500	500	500
32	–	1000	1000	500	500	500	250	250
38	–	1000	1000	500	500	500	250	250
45	–	–	1000	500	500	250	250	250
50	–	–	1000	500	500	250	250	250
60	–	–	–	500	500	250	250	250
70	–	–	–	500	500	250	250	250
80	–	–	–	500	500	250	250	250
90	–	–	–	–	500	250	–	250
100	–	–	–	–	–	250	–	250
120	–	–	–	–	–	–	–	250

Die handelsüblichen Größen sind durch Angabe der VPE gekennzeichnet.
Lieferbar in Stahl sowie Edelstahl A2

Maße in mm

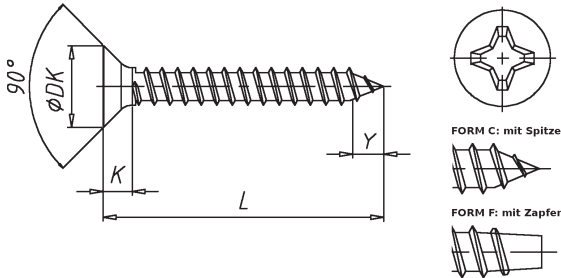

D	2,2	2,9	3,5	3,9	4,2	4,8	5,5	6,3
DK	4,3	5,5	6,8	7,5	8,1	9,5	10,8	12,4
K	1,3	1,7	2,1	2,3	2,5	3	3,4	3,8
Y	2	2,6	3,2	3,5	3,7	4,3	5	6

VPE

L \ D	2,2	2,9	3,5	3,9	4,2	4,8	5,5	6,3
6,5	1000	1000	1000	–	–	–	–	–
9,5	1000	1000	1000	1000	1000	1000	–	–
13	1000	1000	1000	1000	1000	1000	500	–
16	1000	1000	1000	1000	1000	1000	500	500
19	1000	1000	1000	1000	1000	1000	500	500
22	–	1000	1000	1000	1000	1000	500	500
25	–	1000	1000	1000	1000	1000	500	500
32	–	1000	1000	1000	1000	500	500	250
38	–	–	1000	1000	500	500	500	250
45	–	–	1000	1000	500	500	500	250
50	–	–	1000	1000	500	250	250	250
60	–	–	–	–	500	250	250	250
70	–	–	–	–	500	250	250	250
80	–	–	–	–	–	250	250	250
90	–	–	–	–	–	–	–	250
100	–	–	–	–	–	–	–	200

Die handelsüblichen Größen sind durch Angabe der VPE gekennzeichnet.
Lieferbar in Stahl sowie Edelstahl A2



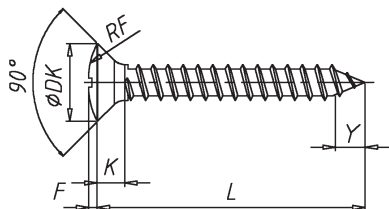

FORM C: mit Spitze



FORM F: mit Zapfen

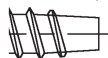

Maße in mm

D	2,2	2,9	3,5	3,9	4,2	4,8	5,5	6,3
DK	4,3	5,5	6,8	7,5	8,1	9,5	10,8	12,4
F	0,7	0,9	1,2	1,3	1,4	1,5	1,7	2
K	1,3	1,7	2,1	2,3	2,5	3	3,4	3,8
Y	2	2,6	3,2	3,5	3,7	4,3	5	6

VPE

L \ D	2,2	2,9	3,5	3,9	4,2	4,8	5,5	6,3
6,5	1000	1000	–	–	–	–	–	–
9,5	1000	1000	1000	1000	1000	–	–	–
13	1000	1000	1000	1000	1000	1000	–	–
16	1000	1000	1000	1000	1000	1000	500	500
19	–	1000	1000	1000	1000	1000	500	500
22	–	1000	1000	1000	1000	1000	500	500
25	–	1000	1000	1000	1000	1000	500	500
32	–	–	1000	1000	1000	500	500	250
38	–	–	1000	1000	500	500	500	250
45	–	–	–	–	500	500	250	250
50	–	–	–	–	500	250	250	250
60	–	–	–	–	500	250	–	–
70	–	–	–	–	–	250	–	–
80	–	–	–	–	–	250	–	–
90	–	–	–	–	–	250	–	–

Die handelsüblichen Größen sind durch Angabe der VPE gekennzeichnet.
Lieferbar in Stahl sowie Edelstahl A2



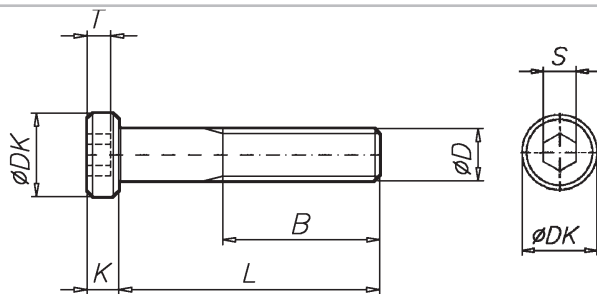

Maße in mm

D	M3	M4	M5	M6	M8	M10	M12	M14	M16	M20	M24
P ¹⁾	0,5	0,7	0,8	1	1,25	1,5	1,75	2	2	2,5	3
B ²⁾	12	14	16	18	22	26	30	34	38	46	54
B ³⁾	-	-	-	-	28	32	36	40	44	52	60
B ⁴⁾	-	-	-	-	-	-	-	-	57	65	73
DK	5,5	7	8,5	10	13	16	18	21	24	30	36
K	2	2,8	3,5	4	5	6	7	8	9	11	13
S	2	2,5	3	4	5	7	8	10	12	14	17
T	1,5	2,3	2,7	3	3,8	4,5	5	5,3	5,5	7,5	8

¹⁾ Gewindesteigung

²⁾ B für L ≤ 125

³⁾ B für 125 < L ≤ 200

⁴⁾ B für L > 200

VPE

L \ D	M3	M4	M5	M6	M8	M10	M12	M16	M20	M24
4	1000	–	–	–	–	–	–	–	–	–
5	1000	500	–	–	–	–	–	–	–	–
6	500	500	500	–	–	–	–	–	–	–
8	500	500	500	500	–	–	–	–	–	–
10	500	500	500	500	200	–	–	–	–	–
12	500	500	500	500	200	200	–	–	–	–
14	500	500	500	500	200	–	–	–	–	–
16	500	500	500	500	200	200	100	–	–	–
18	500	500	500	500	200	200	–	–	–	–
20	500	500	500	500	200	200	100	50	–	–
22	500	500	500	500	200	200	–	–	–	–
25	500	500	500	500	200	200	100	50	–	–
30	500	500	500	500	200	200	100	50	25	–
35	500	500	500	500	200	100	100	50	25	–
40	500	500	500	500	200	100	100	50	25	–
45	–	500	500	200	200	100	100	50	25	–
50	–	–	500	200	200	100	100	50	25	25
55	–	–	200	200	200	100	100	50	–	–
60	–	–	200	200	200	100	100	50	25	25
65	–	–	200	200	200	100	100	–	–	–
70	–	–	200	200	100	100	100	25	25	25
80	–	–	–	200	100	100	100	25	25	25
90	–	–	–	–	100	100	100	25	25	25
100	–	–	–	–	100	100	100	25	25	25
120	–	–	–	–	–	–	100	25	–	–

Die handelsüblichen Größen sind durch Angabe der VPE gekennzeichnet.
Lieferbar in Güte: 8.8, 10.9 sowie Edelstahl A2





Maße in mm

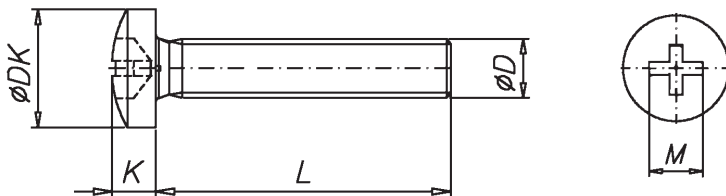

D	M2	M2,5	M3	M3,5	M4	M5	M6	M8	M10
P ¹⁾	0,4	0,45	0,5	0,6	0,7	0,8	1	1,25	1,5
DK	4	5	6	7	8	10	12	16	20
K	1,6	2	2,4	2,7	3,1	3,8	4,6	6	7,5
M	2,5	2,7	3,1	4,2	4,6	5,3	6,8	9	10,2

¹⁾ Gewindesteigung

VPE

L \ D	M2	M2,5	M3	M3,5	M4	M5	M6	M8
3	1000	–	–	–	–	–	–	–
4	1000	1000	1000	–	1000	–	–	–
5	1000	1000	1000	–	1000	–	–	–
6	1000	1000	1000	1000	1000	500	–	–
8	1000	1000	1000	1000	1000	500	500	–
10	1000	1000	1000	1000	1000	500	200	200
12	1000	1000	1000	1000	1000	500	200	200
14	–	1000	1000	–	1000	500	200	–
16	1000	1000	1000	1000	1000	200	200	200
18	–	–	1000	–	1000	200	–	–
20	1000	1000	1000	1000	1000	200	200	200
25	–	1000	1000	1000	500	200	200	200
30	–	1000	1000	1000	500	200	200	200
35	–	–	500	–	500	200	200	200
40	–	–	500	–	500	200	200	200
45	–	–	500	–	500	200	200	200
50	–	–	500	–	500	200	200	200
55	–	–	500	–	500	200	200	–
60	–	–	–	–	500	200	200	200
70	–	–	–	–	200	200	200	–
80	–	–	–	–	200	200	200	–

Die handelsüblichen Größen sind durch Angabe der VPE gekennzeichnet.
Lieferbar in Güte: 4.8 sowie Edelstahl A2





Maße in mm

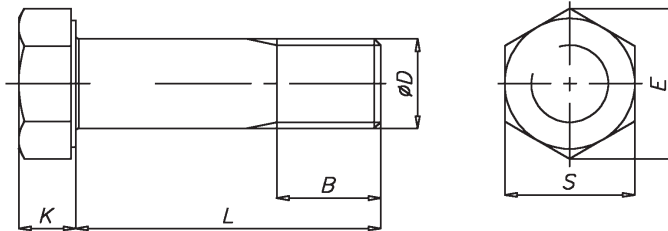

D	M12	M16	M20	M24	M27	M30
P ¹⁾	1,75	2	2,5	3	3	3,5
B	17,75	21	23,5	26	29	30,5
E	19,85	26,17	32,95	39,55	45,2	50,85
K	8	10	13	15	17	19
S	18	24	30	36	41	46

¹⁾ Gewindesteigung

Konform nach EN 15048-1
Mit SB-Kennzeichnung.
Mit CE-Kennzeichnung.

VPE

L \ D	M12	M16	M20	M24	M27
30	100	–	–	–	–
35	100	50	–	–	–
40	100	50	25	–	–
45	100	50	25	–	–
50	100	50	25	25	–
55	100	50	25	25	–
60	100	50	25	25	10
65	50	25	25	25	10
70	50	25	25	25	10
75	50	25	25	25	10
80	50	25	25	25	10
85	50	25	25	10	10
90	50	25	25	10	10
95	50	25	25	10	10
100	50	25	25	10	10
105	50	25	25	10	10
110	50	25	25	10	10
115	50	25	25	10	10
120	50	25	25	10	10
125	–	25	25	10	10
130	–	25	25	10	10
135	–	25	25	10	10
140	–	25	25	10	10
145	–	25	25	10	10
150	–	25	25	10	10
155	–	–	10	–	–
160	–	–	10	10	–

Die handelsüblichen Größen sind durch Angabe der VPE gekennzeichnet.
Lieferbar in Güte: 4.6



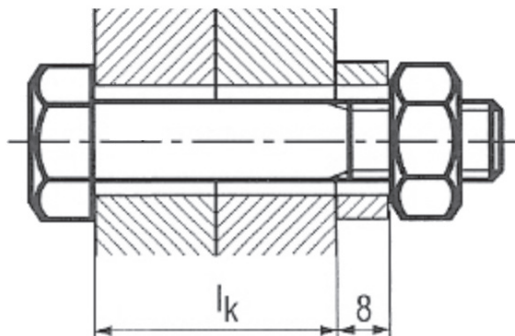

Maße in mm

Klemmlänge (l_k)

Länge \ d	M12	M16	M20	M22	M24	M27	M30
30	5 – 9	-	-	-	-	-	-
35	10 – 14	6 – 10	-	-	-	-	-
40	15 – 19	11 – 15	8 – 12	6 – 10	-	-	-
45	20 – 24	16 – 20	13 – 17	11 – 15	9 – 13	-	-
50	25 – 29	21 – 25	18 – 22	16 – 20	14 – 18	-	-
55	30 – 34	26 – 30	23 – 27	21 – 25	19 – 23	-	-
60	35 – 39	31 – 35	28 – 32	26 – 30	24 – 28	21 – 25	-
65	40 – 44	36 – 40	33 – 37	31 – 35	29 – 33	26 – 30	-
70	45 – 49	41 – 45	38 – 42	36 – 40	34 – 38	31 – 35	-
75	50 – 54	46 – 50	43 – 47	41 – 45	39 – 43	36 – 40	-
80	55 – 59	51 – 55	48 – 52	46 – 50	44 – 48	41 – 45	39 – 43
85	60 – 64	56 – 60	53 – 57	51 – 55	49 – 53	46 – 50	44 – 48
90	65 – 69	61 – 65	58 – 62	56 – 60	54 – 58	51 – 55	49 – 53
95	70 – 74	66 – 70	63 – 67	61 – 65	59 – 63	56 – 60	54 – 58
100	75 – 79	71 – 75	68 – 72	66 – 70	64 – 68	61 – 65	59 – 63
105	80 – 84	76 – 80	73 – 77	71 – 75	69 – 73	66 – 70	64 – 68
110	85 – 89	81 – 85	78 – 82	76 – 80	74 – 78	71 – 75	69 – 73
115	90 – 94	86 – 90	83 – 87	81 – 85	79 – 83	76 – 80	74 – 78
120	95 – 99	91 – 95	88 – 92	86 – 90	84 – 88	81 – 85	79 – 83
125	-	96 – 100	93 – 97	91 – 95	89 – 93	86 – 90	84 – 88
130	-	101 – 105	98 – 102	96 – 100	94 – 98	91 – 95	89 – 93
135	-	106 – 110	103 – 107	101 – 105	99 – 103	96 – 100	94 – 98

Länge \ d	Klemmlänge (l_k)						
	M12	M16	M20	M22	M24	M27	M30
140	-	111 – 115	108 – 112	106 – 110	104 – 108	101 – 105	99 – 103
145	-	116 – 120	113 – 117	111 – 115	109 – 113	106 – 110	104 – 108
150	-	121 – 125	118 – 122	116 – 120	114 – 118	111 – 115	109 – 113
155	-	-	123 – 127	121 – 125	119 – 123	116 – 120	114 – 118
160	-	-	128 – 132	126 – 130	124 – 128	121 – 125	119 – 123
165	-	-	133 – 137	131 – 135	129 – 133	126 – 130	124 – 128
170	-	-	138 – 142	136 – 140	134 – 138	131 – 135	129 – 133
175	-	-	143 – 147	141 – 145	139 – 143	136 – 140	134 – 138
180	-	-	-	146 – 150	144 – 148	141 – 145	139 – 143
185	-	-	-	151 – 155	149 – 153	146 – 150	144 – 148
190	-	-	-	156 – 160	154 – 158	151 – 155	149 – 153
195	-	-	-	161 – 165	159 – 163	156 – 160	154 – 158
200	-	-	-	166 – 170	164 – 168	161 – 165	159 – 163

Die Klemmlänge (l_k) wird ohne Scheibe gemessen.





Maße in mm

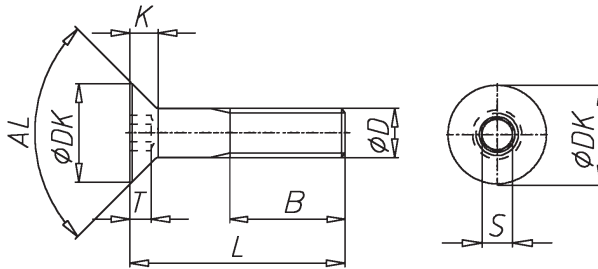

D	M3	M4	M5	M6	M8	M10	M12	M16	M20	M22	M24
P ¹⁾	0,5	0,7	0,8	1	1,25	1,5	1,75	2	2,5	2,5	3
AL	90°	90°	90°	90°	90°	90°	90°	90°	90°	60°	60°
B ²⁾	12	14	16	18	22	26	30	38	46	50	54
B ³⁾	-	-	-	24	28	32	36	44	52	56	60
B ⁴⁾	-	-	-	-	-	45	49	57	65	69	73
DK _{DIN 7991}	6	8	10	12	16	20	24	30	36	36	39
DK _{ISO 10642} ⁵⁾	6,72	8,96	11,2	13,44	17,92	22,4	26,88	33,6	40,32	-	-
K _{DIN 7991}	1,7	2,3	2,8	3,3	4,4	5,5	6,5	7,5	8,5	13,1	14
K _{ISO 10642} ⁵⁾	1,86	2,48	3,1	3,72	4,96	6,2	7,44	8,8	10,16	-	-
S	2	2,5	3	4	5	6	8	10	12	14	14
T	1,2	1,8	2,3	2,5	3,5	4,4	4,6	5,3	5,9	8,8	10,3

¹⁾ Gewindesteigung

²⁾ B für L ≤ 125

³⁾ B für 125 < L ≤ 200

⁴⁾ B für L > 200

⁵⁾ maximaler Wert nach EN ISO 10642:2004, zu beachten ist, dass die Senkung nach DIN 74 Form F ausgeführt wird.

VPE

L \ D	M3	M4	M5	M6	M8	M10	M12	M16	M20	M24
5	1000	–	–	–	–	–	–	–	–	–
6	1000	500	500	–	–	–	–	–	–	–
8	1000	500	500	500	–	–	–	–	–	–
10	1000	500	500	500	200	–	–	–	–	–
12	500	500	500	500	200	200	–	–	–	–
14	500	500	500	500	200	–	–	–	–	–
16	500	500	500	500	200	200	100	–	–	–
18	500	500	500	500	200	200	–	–	–	–
20	500	500	500	500	200	200	100	–	–	–
25	500	500	500	500	200	200	100	50	–	–
30	500	500	500	500	200	200	100	50	–	–
35	500	500	500	200	200	100	100	50	25	–
40	–	500	200	200	200	100	100	50	25	–
45	–	500	200	200	200	100	100	50	25	25
50	–	500	200	200	200	100	100	50	25	25
55	–	500	200	200	200	100	100	50	25	–
60	–	500	200	200	200	100	100	50	25	25
65	–	–	–	200	200	100	100	25	–	–
70	–	–	200	200	200	100	100	25	25	25
80	–	–	200	200	100	100	50	25	25	25
90	–	–	–	200	100	100	50	25	25	25
100	–	–	–	200	100	100	50	25	25	25
110	–	–	–	–	100	50	50	25	25	25
120	–	–	–	200	100	50	50	25	25	25
130	–	–	–	–	–	50	50	25	25	25
140	–	–	–	–	100	50	50	25	25	–
150	–	–	–	–	–	50	50	25	25	–
160	–	–	–	–	–	50	–	25	25	–
180	–	–	–	–	–	–	–	25	25	–
200	–	–	–	–	–	–	–	25	25	–

Die handelsüblichen Größen sind durch Angabe der VPE gekennzeichnet.
Lieferbar in Güte: 8.8, 10.9 sowie Edelstahl A2 und Edelstahl A4





Maße in mm

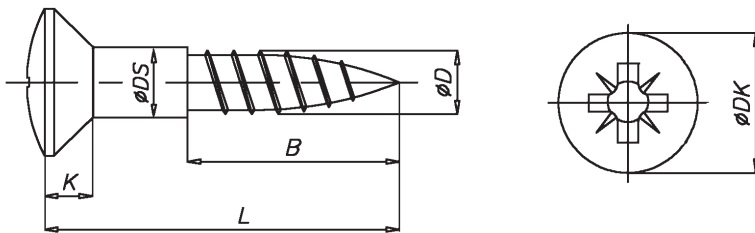

D	3	3,5	4	4,5	5	6
DS	3	3,5	4	4,5	5	6
DK	5,6	6,5	7,5	8,3	9,2	11
K	1,65	1,93	2,2	2,35	2,5	3
KR	1	2	2	2	2	3

VPE

L \ D	3	3,5	4	4,5	5	6
16	200	–	–	–	–	–
20	200	200	200	–	–	–
25	200	200	200	200	200	–
30	200	200	200	200	200	–
35	200	200	200	200	200	–
40	200	200	200	200	200	100
45	–	200	200	200	200	–
50	–	200	200	200	200	100
60	–	–	200	200	200	100
70	–	–	–	–	200	100
80	–	–	–	–	200	100
90	–	–	–	–	200	100
100	–	–	–	–	200	100

Die handelsüblichen Größen sind durch Angabe der VPE gekennzeichnet.
Lieferbar in Stahl sowie Edelstahl A2

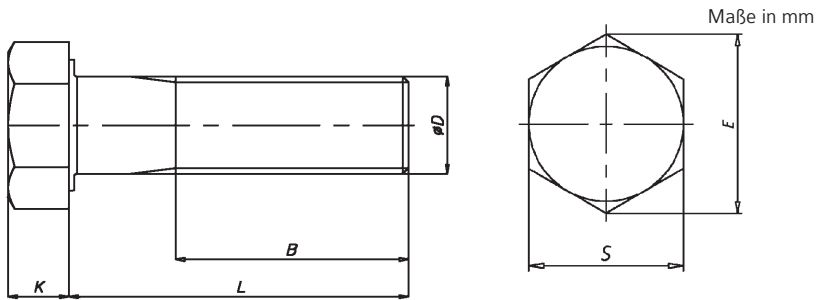

D	M8	M10	M12	M16	M20
P ¹⁾	1,25	1,5	1,75	2	2,5
(für ISO 4014) B ²⁾	22	26	30	38	46
(für ISO 4014) B ³⁾	28	32	36	44	52
(für ISO 4014) B ⁴⁾	-	45	49	57	65
K	5,3	6,4	7,5	10	12,5
S	13	16	18	24	30

D	M22	M24	M27	M30	M36
P ¹⁾	2,5	3	3	3,5	4
(für ISO 4014) B ²⁾	50	54	60	66	78
(für ISO 4014) B ³⁾	56	60	66	72	84
(für ISO 4014) B ⁴⁾	69	73	79	85	97
K	14	15	17	18,7	22,5
S	32	36	41	46	55

¹⁾ Gewindesteigung

²⁾ B für $L \leq 125$

³⁾ B für $125 < L \leq 200$

⁴⁾ B für $L > 200$



ISO 4014 nach DIN EN 15048

Structural Bolt
Garnitur



Maße in mm

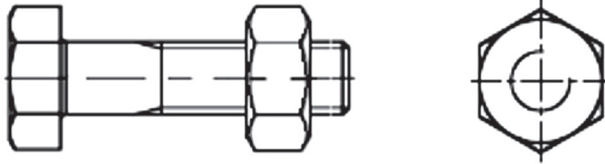

Nennmaß	S	B	VPE
12X45 SB-CE	18	30	100
12X50 SB-CE	18	30	100
12X55 SB-CE	18	30	100
12X60 SB-CE	18	30	75
12X70 SB-CE	18	30	75
12X80 SB-CE	18	30	50
12X90 SB-CE	18	30	50
12X100 SB-CE	18	30	50
12X110 SB-CE	18	30	50
12X120 SB-CE	18	30	50
12X140 SB-CE	18	36	50
16X55 SB-CE	24	38	50
16X60 SB-CE	24	38	50
16X65 SB-CE	24	38	50
16X70 SB-CE	24	38	25
16X80 SB-CE	24	38	25
16X90 SB-CE	24	38	25
16X100 SB-CE	24	38	25
16X110 SB-CE	24	38	25
16X120 SB-CE	24	38	25
16X130 SB-CE	24	44	25
16X140 SB-CE	24	44	25
16X150 SB-CE	24	44	25
16X160 SB-CE	24	44	25

Nennmaß	S	B	VPE
20X65 SB-CE	30	46	25
20X70 SB-CE	30	46	25
20X80 SB-CE	30	46	20
20X90 SB-CE	30	46	20
20X100 SB-CE	30	46	20
20X110 SB-CE	30	46	20
20X120 SB-CE	30	46	20
20X130 SB-CE	30	52	20
20X140 SB-CE	30	52	10
20X150 SB-CE	30	52	10
20X160 SB-CE	30	52	10
20X180 SB-CE	30	52	10
22X80 SB-CE	34	50	15
22X100 SB-CE	34	50	15
22X120 SB-CE	34	50	15
24X70 SB-CE	36	54	10
24X80 SB-CE	36	54	10
24X90 SB-CE	36	54	10
24X100 SB-CE	36	54	10
24X110 SB-CE	36	54	10
24X120 SB-CE	36	54	10
24X130 SB-CE	36	60	10
24x140 SB-CE	36	60	10

Maße in mm

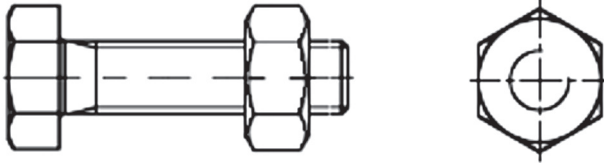

Nennmaß	SW	VPE
12X20 SB-CE	18	100
12X25 SB-CE	18	100
12X30 SB-CE	18	100
12X35 SB-CE	18	100
12X40 SB-CE	18	100
12X45 SB-CE	18	100
12X50 SB-CE	18	100
12X60 SB-CE	18	75
12X70 SB-CE	18	75
12X80 SB-CE	18	50
16X30 SB-CE	24	50
16X35 SB-CE	24	50
16X40 SB-CE	24	50
16X45 SB-CE	24	50

Nennmaß	SW	VPE
16X50 SB-CE	24	50
16X55 SB-CE	24	50
16X60 SB-CE	24	50
16X70 SB-CE	24	25
20X40 SB-CE	30	25
20X45 SB-CE	30	25
20X50 SB-CE	30	25
20X55 SB-CE	30	25
20X60 SB-CE	30	25
20X70 SB-CE	30	25
20X80 SB-CE	30	20
20X90 SB-CE	30	20
24X50 SB-CE	36	20
24X60 SB-CE	36	10

SB-Garnituren nach EN 15048, bestehen aus Schraube ISO 4014 / 4017 und Mutter ISO 4032 (ohne Scheibe ISO 7090) für nicht planmäßig vorgespannte Schraubenverbindungen für den Metallbau.

Die Garnituren sind SB und CE gekennzeichnet. Die Brauchbarkeit nach der Bauproduktenverordnung ist somit belegt.

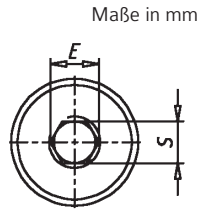
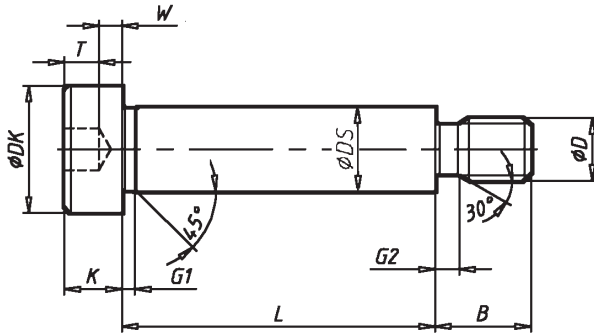

Maße in mm

DS	6	8	10	12	16	20
D	M5	M6	M8	M10	M12	M16
P ¹⁾	0,8	1	1,25	1,5	1,75	2
DK	10	13	16	18	24	30
K	4,5	5,5	7	9	11	14
T	2,4	3,3	4,2	4,9	6,6	8,8
B	9,5	11	13	16	18	22
G1	2,5	2,5	2,5	2,5	2,5	2,5
G2	2	2,5	3,1	3,7	4,4	5
E	3,44	4,58	5,72	6,86	9,15	11,43
S	3	4	5	6	8	10

¹⁾ Gewindesteigung

VPE

L \ DS	6	8	10	12	16	20
10	50	50	50	-	-	-
12	50	50	50	-	-	-
16	50	50	50	50	25	-
20	50	50	50	50	25	-
25	50	50	50	50	25	-
30	50	50	50	50	25	-
35	50	50	50	50	25	-
40	50	50	50	50	25	10
50	50	50	50	50	25	10
60	50	50	50	50	25	10
70	-	50	50	25	25	10
80	-	50	50	25	25	10
90	-	-	-	25	25	10
100	-	-	-	25	25	10

Die handelsüblichen Größen sind durch Angabe der VPE gekennzeichnet.
Lieferbar in Güte 12.9 Standard-Passmaß: f9, weitere Passungen auf Anfrage lieferbar.

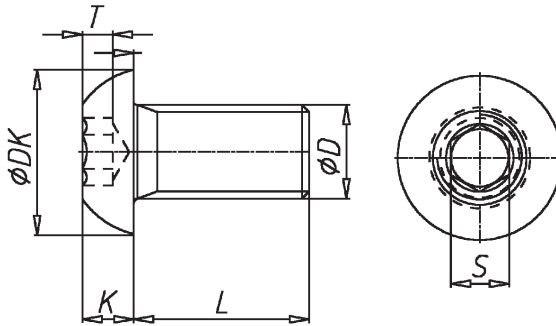

Maße in mm

D	M3	M4	M5	M6	M8	M10	M12
P ¹⁾	0,5	0,7	0,8	1	1,25	1,5	1,75
DK	5,7	7,6	9,5	10,5	14	17,5	21
K	1,65	2,2	2,75	3,3	4,4	5,5	6,6
S	2	2,5	3	4	5	6	8
T	1,04	1,3	1,56	2,08	2,6	3,12	4,16

¹⁾ Gewindesteigung

VPE

L \ D	M3	M4	M5	M6	M8	M10	M12
4	1000	–	–	–	–	–	–
5	1000	–	–	–	–	–	–
6	1000	1000	500	500	–	–	–
8	1000	1000	500	500	200	–	–
10	1000	1000	500	500	200	–	–
12	1000	1000	500	500	200	200	–
14	1000	1000	500	500	200	–	–
16	1000	1000	500	500	200	100	–
18	1000	1000	500	500	200	–	–
20	1000	1000	500	500	200	200	100
25	1000	500	500	500	200	200	100
30	500	500	500	500	200	200	100
35	500	500	500	500	200	100	100
40	500	500	500	500	200	100	100
45	–	–	200	200	200	100	100
50	–	–	200	200	200	100	100
60	–	–	200	200	200	100	100
70	–	–	–	200	200	100	50
80	–	–	–	–	200	100	50
90	–	–	–	–	200	100	50
100	–	–	–	–	100	100	50

Die handelsüblichen Größen sind durch Angabe der VPE gekennzeichnet.
Lieferbar in Güte: 10.9 sowie Edelstahl A2



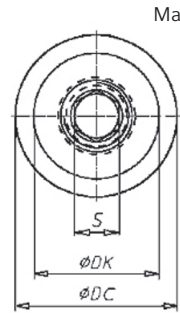
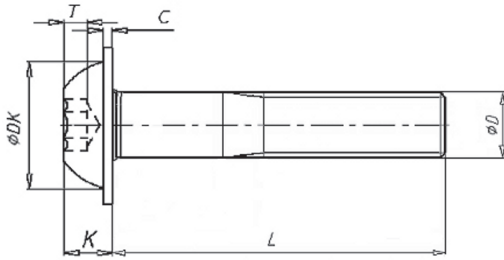

Maße in mm

D	M3	M4	M5	M6	M8	M10	M12
P ¹⁾	0,5	0,7	0,8	1	1,25	1,5	1,75
C	0,7	0,8	1	1,1	1,5	1,7	2,4
DC	7	9,4	11,6	13,6	17,8	22	25
DK	5,2	7,2	8,8	10	13,2	16,5	19,4
K	1,65	2,2	2,75	3,3	4,4	5,5	6,6
S	2	2,5	3	4	5	6	8
T	1,04	1,3	1,56	2,08	2,6	3,12	4,16

¹⁾ Gewindesteigung

VPE

L \ D	M3	M4	M5	M6	M8	M10	M12
4	1000	–	–	–	–	–	–
5	1000	1000	–	–	–	–	–
6	1000	1000	500	500	–	–	–
8	1000	1000	500	500	200	–	–
10	1000	500	500	500	200	–	–
12	1000	500	500	500	200	–	–
14	1000	500	500	500	200	200	–
16	1000	500	500	500	200	100	100
18	1000	500	500	500	–	–	–
20	1000	500	500	500	200	100	100
22	–	–	500	500	200	–	–
25	500	500	500	500	200	100	100
30	500	500	500	200	200	100	100
35	500	500	200	200	200	100	100
40	500	200	200	200	200	100	100
45	–	–	200	200	200	100	100
50	–	–	200	200	100	100	100
60	–	–	–	200	100	100	100
70	–	–	–	–	100	100	100
80	–	–	–	–	–	100	100

Die handelsüblichen Größen sind durch Angabe der VPE gekennzeichnet.
Lieferbar in Güte: 10.9 sowie Edelstahl A2



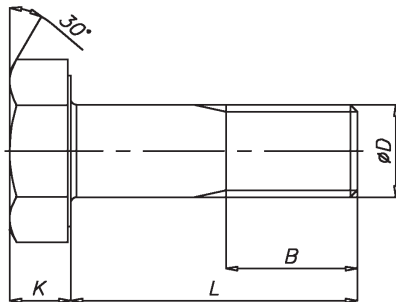

Maße in mm

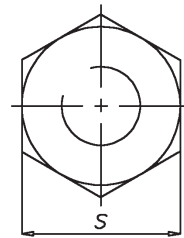

D	M12	M16	M20	M22	M24	M27	M30	M36
P ¹⁾	1,75	2	2,5	2,5	3	3	3,5	4
B	23	28	33	34	39	41	44	52
K	8	10	13	14	15	17	19	23
S	22	27	32	36	41	46	50	60

¹⁾ Gewindesteigung

CE-Gekennzeichnet

VPE

L \ D	M12	M16	M20	M22	M24	M27	M30	M36
30	100	–	–	–	–	–	–	–
35	100	50	–	–	–	–	–	–
40	100	50	25	–	–	–	–	–
45	100	50	25	–	–	–	–	–
50	100	50	25	25	25	–	–	–
55	100	50	25	25	25	–	–	–
60	50	50	25	25	25	10	–	–
65	50	50	25	25	25	10	–	–
70	50	50	25	25	25	10	10	–
75	50	50	25	25	25	10	10	–
80	50	25	25	25	25	10	10	–
85	50	25	25	25	25	10	10	–
90	50	25	25	25	25	10	10	5
95	50	25	25	25	25	10	10	5
100	50	25	25	25	25	10	10	5
105	–	25	25	25	25	10	10	5
110	50	25	25	25	25	10	10	5
115	–	25	25	25	25	10	10	5
120	50	25	25	25	20	10	10	5
125	–	25	25	25	20	10	10	5
130	50	25	25	25	20	10	10	5
135	–	25	25	25	20	10	10	5
140	50	25	25	20	20	10	10	5
145	–	25	25	–	20	10	10	5
150	50	25	25	15	15	10	10	5
155	–	–	20	–	15	10	10	5
160	–	25	20	15	15	10	10	5
165	–	–	20	–	15	10	10	5
170	–	25	20	15	10	10	10	5
175	–	–	20	–	10	10	5	5
180	–	25	15	15	10	10	5	5
185	–	–	–	–	–	–	5	5
190	–	25	15	15	10	10	5	5
200	–	25	15	15	10	10	5	5
205	–	–	–	–	–	–	5	–
210	–	–	15	15	10	10	5	–
220	–	–	15	15	10	10	5	–



Die handelsüblichen Größen sind durch Angabe der VPE gekennzeichnet.
Lieferbar in Güte 10.9

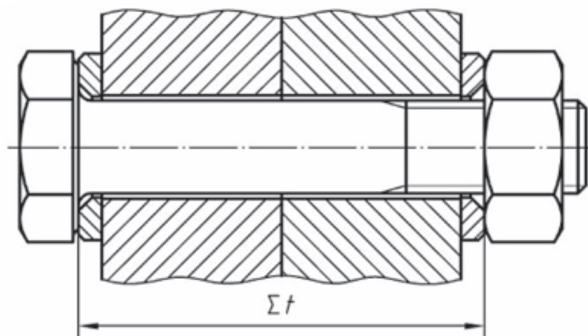

Maße in mm

Σt_{\min} und Σt_{\max}

	M12	M16	M20	M22	M24	M27	M30	M36
Scheibendicke	3	4	4	4	4	5	5	6
Nennlänge l	min. - max.	min. - max.	min. - max.	min. - max.	min. - max.	min. - max.	min. - max.	min. - max.
35	16 - 21	-	-	-	-	-	-	-
40	21 - 26	17 - 22	-	-	-	-	-	-
45	26 - 31	22 - 27	18 - 23	-	-	-	-	-
50	31 - 36	27 - 32	23 - 28	22 - 27	-	-	-	-
55	36 - 41	32 - 37	28 - 33	27 - 32	-	-	-	-
60	41 - 46	37 - 42	33 - 38	32 - 37	29 - 34	-	-	-
65	46 - 51	42 - 47	38 - 43	37 - 42	34 - 39	-	-	-
70	51 - 56	47 - 52	43 - 48	42 - 47	39 - 44	36 - 41	-	-
75	56 - 61	52 - 57	48 - 53	47 - 52	44 - 49	41 - 46	39 - 44	-
80	61 - 66	57 - 62	53 - 58	52 - 57	49 - 54	46 - 51	44 - 49	-
85	66 - 71	62 - 67	58 - 63	57 - 62	54 - 59	51 - 56	49 - 54	43 - 48
90	71 - 76	67 - 72	63 - 68	62 - 67	59 - 64	56 - 61	54 - 59	48 - 53
95	76 - 81	72 - 77	68 - 73	67 - 72	64 - 69	61 - 66	59 - 64	53 - 58
100	-	77 - 82	73 - 78	72 - 77	69 - 74	66 - 71	64 - 69	58 - 63
105	-	82 - 87	78 - 83	77 - 82	74 - 79	71 - 76	69 - 74	63 - 68
110	-	87 - 92	83 - 88	82 - 87	79 - 84	76 - 81	74 - 79	68 - 73
115	-	92 - 97	88 - 93	87 - 92	84 - 89	81 - 86	79 - 84	73 - 78
120	-	97 - 102	93 - 98	92 - 97	89 - 94	86 - 91	84 - 89	78 - 83
125	-	102 - 107	98 - 103	97 - 102	94 - 99	91 - 96	89 - 94	83 - 88
130	-	107 - 112	103 - 108	102 - 107	99 - 104	96 - 101	94 - 99	88 - 93
135	-	-	108 - 113	107 - 112	104 - 109	101 - 106	99 - 104	93 - 98
140	-	-	113 - 118	112 - 117	109 - 114	106 - 111	104 - 109	98 - 103
145	-	-	118 - 123	117 - 122	114 - 119	111 - 116	109 - 114	103 - 108

	M12	M16	M20	M22	M24	M27	M30	M36
Scheibendicke	3	4	4	4	4	5	5	6
Nennlänge l	min. - max.	min. - max.	min. - max.	min. - max.	min. - max.	min. - max.	min. - max.	min. - max.
150	-	-	123 - 128	122 - 127	119 - 124	116 - 121	114 - 119	108 - 113
155	-	-	128 - 133	127 - 132	124 - 129	121 - 126	119 - 124	113 - 118
160	-	-	-	132 - 137	129 - 134	126 - 131	124 - 129	118 - 123
165	-	-	-	137 - 142	134 - 139	131 - 136	129 - 134	123 - 128
170	-	-	-	-	139 - 144	136 - 141	134 - 139	128 - 133
175	-	-	-	-	144 - 149	141 - 146	139 - 144	133 - 138
180	-	-	-	-	149 - 154	146 - 151	144 - 149	138 - 143
185	-	-	-	-	154 - 159	151 - 156	149 - 154	143 - 148
190	-	-	-	-	159 - 164	156 - 161	154 - 159	148 - 153
195	-	-	-	-	164 - 169	161 - 166	159 - 164	153 - 158
200	-	-	-	-	-	166 - 171	164 - 169	158 - 163

Achtung: Im Gegensatz zur DIN 6914 wurde die Definition der Klemmlänge in EN 14399-4 geändert: Klemmlänge ist jetzt der unmittelbare Abstand zwischen dem Kopf der Schraube und der Mutter (das Scheibenpaar wird zum Klemmbereich dazugerechnet).





Maße in mm

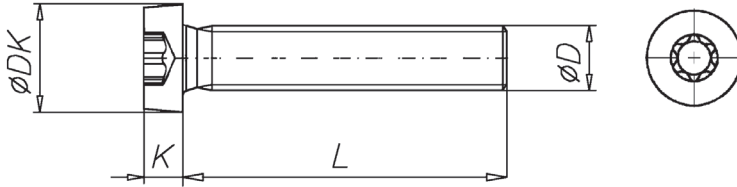

D	M2	M2,5	M3	M4	M5	M6	M8
DK	3,8	4,5	5,5	7	8,5	10	13
K	1,55	1,85	2,4	3,1	3,65	4,4	5,8
BIT	T6	T8	T10	T20	T25	T30	T45

VPE

L \ D	M2	M2,5	M3	M4	M5	M6
3	100	-	-	-	-	-
4	100	-	-	-	-	-
5	100	100	-	-	-	-
6	100	100	100	100	-	-
8	100	100	100	500	500	500
10	100	100	100	500	500	500
12	100	100	100	500	500	500
16	-	-	100	500	500	500
20	-	-	100	500	100	500
25	-	-	-	500	100	100
30	-	-	-	-	100	500

Die handelsüblichen Größen sind durch Angabe der VPE gekennzeichnet.

Maße in mm

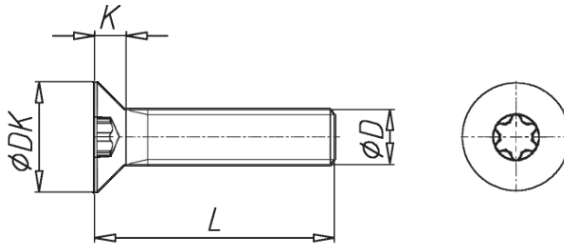

D	M2	M2,5	M3	M4	M5	M6	M8
DK	3,8	4,7	5,5	8,4	9,3	11,3	15,8
K	1,2	1,5	1,65	2,7	2,7	3,3	4,65
BIT	T6	T8	T10	T20	T25	T30	T45

VPE

L \ D	M2	M2,5	M3	M4	M5	M6	M8
3	500	–	–	–	–	–	–
4	500	500	–	–	–	–	–
5	500	500	–	–	–	–	–
6	500	500	500	–	–	–	–
8	500	500	500	500	500	–	–
10	500	500	500	500	500	500	–
12	500	500	500	500	500	500	500
16	–	500	500	500	500	500	500
20	–	–	–	500	500	500	500

Die handelsüblichen Größen sind durch Angabe der VPE gekennzeichnet.





Maße in mm

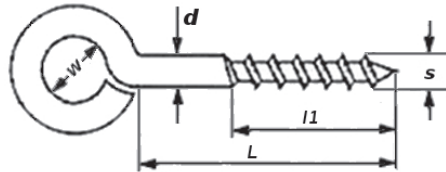

Nennmaß	s	d	w	l1	L	für Dübel	VPE
8/3	2,3	1,8	3	5	8	4	200
8/4	2,8	2,3	4	5	8	4	200
10/3	2,3	1,8	3	7	10	4	200
10/4	2,8	2,3	4	8	10	4	200
10/5	2,8	2,3	5	8	10	4	200
12/4	2,8	2,3	4	8	12	4	200
12/5	2,8	2,3	5	8	12	4	200
12/6	3,6	2,8	6	7	12	5	200
12/8	4,1	3,2	8	7	12	6	100
16/5	3,6	2,8	5	10	16	5	200
16/6	3,6	2,8	6	10	16	5	100
16/8	4,1	3,2	8	10	16	6	100
16/10	4,1	3,2	10	10	16	6	100
16/12	4,1	3,2	12	10	16	6	100
20/6	3,6	2,8	6	12	20	5	200
20/8	4,1	3,2	8	12	20	6	100
20/10	4,1	3,2	10	12	20	6	100
20/12	4,8	3,8	12	13	20	6	100
25/8	4,1	3,2	8	15	25	6	100
25/10	4,1	3,2	10	15	25	6	100
25/12	4,8	3,8	12	16	25	6	100
25/14	4,8	3,8	14	16	25	6	100
30/10	4,1	3,2	10	15	30	6	100

Nennmaß	s	d	w	l1	L	für Dübel	VPE
30/12	4,8	3,8	12	16	30	6	100
30/14	4,8	3,8	14	16	30	6	100
30/16	5,5	4,2	16	16	30	8	100
30/18	5,5	4,2	18	16	30	8	100
40/12	4,8	3,8	12	22	40	6	100
40/14	4,8	3,8	14	22	40	6	100
40/16	5,5	4,2	16	22	40	8	100
40/18	6	4,7	18	22	40	8	100
40/20	6,2	5,2	20	22	40	10	100
50/14	4,8	3,8	14	25	50	6	100
50/16	5,5	4,2	16	25	50	8	100
50/18	6	4,7	18	25	50	8	100
50/20	6,2	5,2	20	25	50	10	100
50/25	6	5,8	18	25	50	8	100

Bei nicht genormten Teilen können die angegebenen Maße herstellungsbedingt abweichen.





Maße in mm

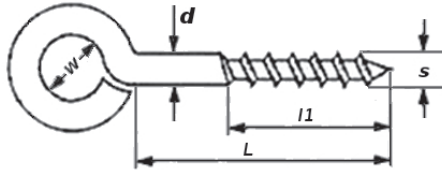

Nennmaß	s	d	w	l1	L	für Dübel	VPE
40/16	5,8	5,8	16	21	40	8	100
50/16	5,8	5,8	16	24	50	8	100
50/18	6,8	6,8	18	25	50	10	100
60/18	6,8	6,8	18	32	60	10	100

Bei nicht genormten Teilen können die angegebenen Maße herstellungsbedingt abweichen.

Maße in mm

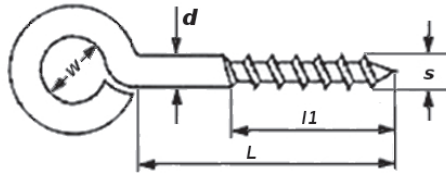

Nennmaß	s	d	w	l1	L	für Dübel	VPE
NR 8	4,8	3,8	8	13	20	6	100
NR 10	4,9	4	8	16	25	6	100
NR 12	6	4,7	8	16	30	8	100
NR 14	5,8	5,8	10	16	30	8	100
NR 16	6,8	6,8	10	20	35	10	100
NR 18	7,8	7,8	12	22	40	12	100

Bei nicht genormten Teilen können die angegebenen Maße herstellungsbedingt abweichen.



1



2



3



4



5



6



7



8



9



Maße in mm

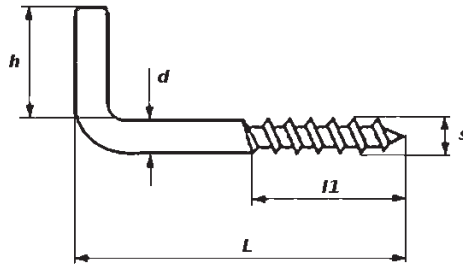

Nennmaß	s	d	h	l1	L	für Dübel	VPE
2,8x20	2,8	2,3	8	8	20	4	200
2,8x25	2,8	2,3	10	10	25	4	200
3,3x30	3,3	2,6	11	12	30	5	200
4,1x40	4,1	3,2	11	15	40	6	100
4,8x50	4,8	3,8	13	22	50	6	100
4,8x60	4,8	3,8	13	25	60	6	100
5,5x70	5,5	4,2	14	32	70	8	100
5,5x80	5,5	4,2	18	32	80	8	100
6x100	6	4,7	18	38	100	8	100

Bei nicht genormten Teilen können die angegebenen Maße herstellungsbedingt abweichen.

Maße in mm

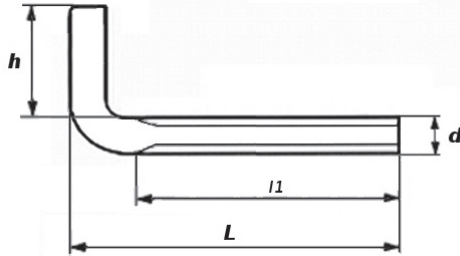

Nennmaß	d	h	l1	L	VPE
M4x40	3,5	10	25	40	100
M4x50	3,5	10	25	50	100
M5x50	4,4	12	35	50	100
M5x60	4,4	12	35	60	100
M6x50	5,2	14	45	50	100
M6x60	5,2	14	45	60	100
M8x60	7	18	45	60	100
M8x80	7	18	45	80	100

Bei nicht genormten Teilen können die angegebenen Maße herstellungsbedingt abweichen.



1



2



3



4



5



6



7



8



9



Maße in mm

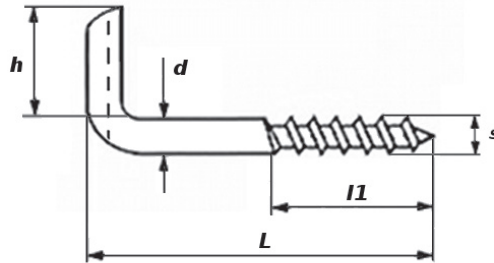

Nennmaß	s	d	h	l1	L	für Dübel	VPE
4,4x30	4,4	4,4	9	13	30	6	100
4,4x40	4,4	4,4	9	18	40	6	100
4,4x50	4,4	4,4	9	22	50	6	100
5,2x30	5,2	5,2	10	13	30	8	100
5,2x40	5,2	5,2	10	18	40	8	100
5,2x50	5,2	5,2	10	22	50	8	100
5,8x65	5,8	5,8	12	30	65	8	100
5,8x80	5,8	5,8	12	30	80	8	100
5,8x100	5,8	5,8	12	38	100	8	100
6,8x100	6,8	6,8	14	38	100	10	100
6,8x120	6,8	6,8	14	42	120	10	100
6,8x150	6,8	6,8	14	48	150	10	50

Bei nicht genormten Teilen können die angegebenen Maße herstellungsbedingt abweichen.

Maße in mm

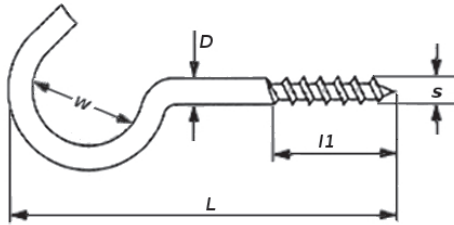

Nennmaß	s	d	w	l1	L	für Dübel	VPE
2,8x20	2,8	2,3	6	8	20	4	200
2,8x25	2,8	2,3	8	8	25	4	200
3,3x30	3,3	2,6	10	10	30	5	200
3,6x40	3,6	2,8	12	12	40	5	100
4,1x50	4,1	3,2	16	15	50	6	100
4,1x60	4,1	3,2	16	22	60	6	100
4,8x70	4,8	3,8	22	22	70	8	100
5,5x80	5,5	4,2	25	25	80	8	100
6x100	6	4,7	25	30	100	8	100

Bei nicht genormten Teilen können die angegebenen Maße herstellungsbedingt abweichen.





Maße in mm

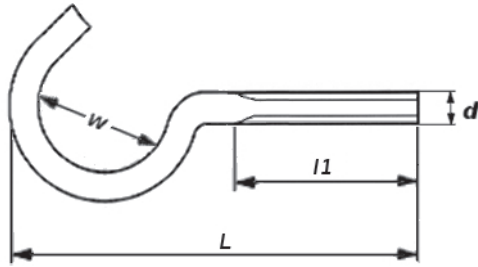

Nennmaß	d	w	l1	L	VPE
M4x40	3,5	12	20	40	100
M4x50	3,5	16	25	50	100
M5x50	4,4	16	23	50	100
M5x60	4,4	16	30	60	100
M6x50	5,2	18	20	50	100
M6x60	5,2	18	30	60	100
M8x70	7	22	32	70	100
M8x80	7	22	42	80	100

Bei nicht genormten Teilen können die angegebenen Maße herstellungsbedingt abweichen.

Maße in mm

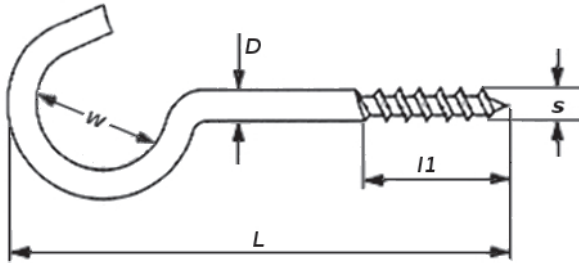

Nennmaß	s	d	w	l1	L	für Dübel	VPE
5,2x80	5,2	5,2	20	25	80	8	50
5,8x100	5,8	5,8	22	32	100	8	50
6,2x120	6,2	6,2	25	38	120	10	50
6,2x140	6,2	6,2	30	45	140	10	50
6,2x160	6,2	6,2	30	45	160	10	50
6,2x180	6,2	6,2	30	45	180	10	50
7,8x200	7,8	7,8	30	58	200	12	50

Bei nicht genormten Teilen können die angegebenen Maße herstellungsbedingt abweichen.





Maße in mm

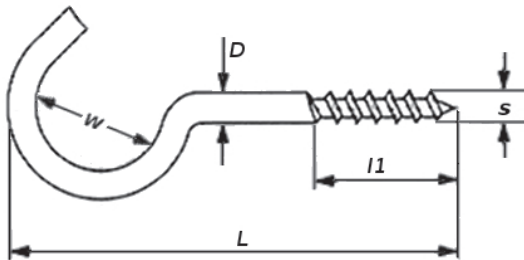

Nennmaß	s	d	w	l1	L	für Dübel	VPE
4,2x50	5,5	4,2	16	16	50	8	100
4,7x65	6	4,7	22	21	65	8	100
5,2x80	6,4	5,2	25	24	80	8	100
5,8x80	5,8	5,8	25	24	80	8	100
5,8x90	5,8	5,8	25	32	90	8	100
6,5x90	6,8	6,5	25	32	90	10	100
6,8x100	6,8	6,8	25	32	100	10	50
6,8x120	6,8	6,8	25	32	120	10	50

Bei nicht genormten Teilen können die angegebenen Maße herstellungsbedingt abweichen.

Maße in mm

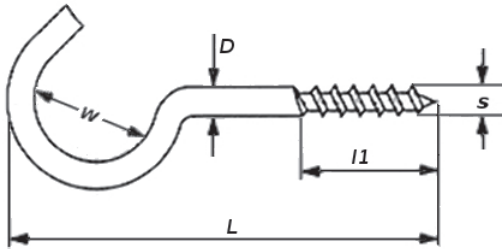

Nennmaß	s	d	w	l1	L	für Dübel	VPE
50	4,1	3,2	16	15	50	6	100
60	4,1	3,2	16	22	60	6	100
70	4,8	3,8	16	22	70	6	100
80	4,8	3,8	16	22	80	6	100
100	5,5	4,2	20	34	100	8	100
120	5,5	4,2	20	34	120	8	100

Bei nicht genormten Teilen können die angegebenen Maße herstellungsbedingt abweichen.





Maße in mm

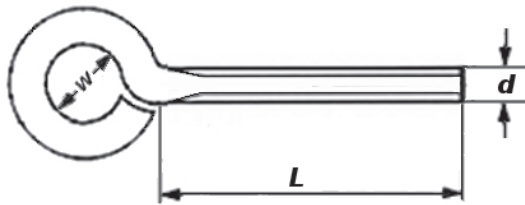

Nennmaß	d	w	l ¹⁾	L	VPE
M3x10	2,6	5	10	11	100
M3x15	2,6	5	15	16	100
M3x20	2,6	5	20	21	100
M4x10	3,5	6	10	11	100
M4x15	3,5	6	15	16	100
M4x20	3,5	6	20	21	100
M4x25	3,5	6	25	26	100
M4x30	3,5	6	30	32	100
M4x40	3,5	6	40	42	100
M5x10	4,4	8	10	11	100
M5x15	4,4	8	15	16	100
M5x20	4,4	8	20	21	100
M5x25	4,4	8	25	26	100
M5x30	4,4	8	30	32	100
M5x40	4,4	8	40	42	100
M5x50	4,4	8	50	52	100
M5x60	4,4	8	60	62	100
M6x15	5,2	10	15	16	100
M6x20	5,2	10	20	21	100
M6x25	5,2	10	25	26	100
M6x30	5,2	10	30	32	100
M6x40	5,2	10	40	42	100
M6x50	5,2	10	50	52	100

Nennmaß	d	w	l ₁	L	VPE
M6x60	5,2	10	60	62	100
M6x70	5,2	10	70	72	100
M6x80	5,2	10	80	82	100
M8x20	7	12	20	21	100
M8x25	7	12	25	26	100
M8x30	7	12	30	32	100
M8x40	7	12	40	42	100
M8x50	7	12	50	52	100
M8x60	7	12	60	62	50
M8x70	7	12	70	72	50
M8x80	7	12	80	82	50
M8x100	7	12	100	102	50
M8x150	7	12	150	152	50
M10x30	8,9	14	30	32	50
M10x40	8,9	14	40	42	50
M10x50	8,9	14	50	52	50
M10x60	8,9	14	60	62	50
M10x80	8,9	14	80	82	50
M10x100	8,9	14	100	102	50
M12X40	10,6	18	40	42	50
M12X60	10,6	18	60	62	50
M12X100	10,6	18	100	102	50

¹⁾ Nutzbare Gewindelänge

Nennmaß = d x l₁

Bei nicht genormten Teilen können die angegebenen Maße herstellungsbedingt abweichen.



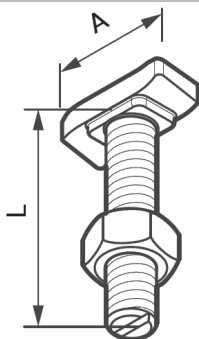

Maße in mm









Nennmaß	A	L	S ¹⁾	VPE
20/12 6X20	15,5	20	20/12	100
20/12 6X30	15,5	30	20/12	100
20/12 6X40	15,5	40	20/12	100
20/12 6X50	15,5	50	20/12	100
20/12 6X60	15,5	60	20/12	100
20/12 8X15	15,5	15	20/12	100
20/12 8X20	15,5	20	20/12	100
20/12 8X25	15,5	25	20/12	100
20/12 8X30	15,5	30	20/12	100
20/12 8X40	15,5	40	20/12	100
20/12 8X50	15,5	50	20/12	100
20/12 8X60	15,5	60	20/12	100
20/12 8X100	15,5	100	20/12	100
28/15 6X15	22,5	15	28/28, 28/15, 26/26	100
28/15 6X20	22,5	20	28/28, 28/15, 26/26	100
28/15 6X25	22,5	25	28/28, 28/15, 26/26	100
28/15 6X30	22,5	30	28/28, 28/15, 26/26	100
28/15 6X40	22,5	40	28/28, 28/15, 26/26	100
28/15 6X50	22,5	50	28/28, 28/15, 26/26	100
28/15 6X60	22,5	60	28/28, 28/15, 26/26	100
28/15 8X15	22,5	15	28/28, 28/15, 26/26	100
28/15 8X20	22,5	20	28/28, 28/15, 26/26	100
28/15 8X25	22,5	25	28/28, 28/15, 26/26	100

¹⁾ geeignet für Profile

Nennmaß	A	L	S ¹⁾	VPE
28/15 8X30	22,5	30	28/28, 28/15, 26/26	100
28/15 8X40	22,5	40	28/28, 28/15, 26/26	100
28/15 8X50	22,5	50	28/28, 28/15, 26/26	100
28/15 8X60	22,5	60	28/28, 28/15, 26/26	100
28/15 8X80	22,5	80	28/28, 28/15, 26/26	100
28/15 8X100	22,5	100	28/28, 28/15, 26/26	100
28/15 8X150	22,5	150	28/28, 28/15, 26/26	50
28/15 10X15	22,5	15	28/28, 28/15, 26/26	100
28/15 10X20	22,5	20	28/28, 28/15, 26/26	100
28/15 10X25	22,5	25	28/28, 28/15, 26/26	100
28/15 10X30	22,5	30	28/28, 28/15, 26/26	100
28/15 10X40	22,5	40	28/28, 28/15, 26/26	100
28/15 10X50	22,5	50	28/28, 28/15, 26/26	100
28/15 10X60	22,5	60	28/28, 28/15, 26/26	100
28/15 10X80	22,5	80	28/28, 28/15, 26/26	100
28/15 10X100	22,5	100	28/28, 28/15, 26/26	50
28/15 10X125	22,5	125	28/28, 28/15, 26/26	50
28/15 10X150	22,5	150	28/28, 28/15, 26/26	50
28/15 10X200	22,5	200	28/28, 28/15, 26/26	50
28/15 12X30	22,5	30	28/28, 28/15, 26/26	100
28/15 12X50	22,5	50	28/28, 28/15, 26/26	50
28/15 12X80	22,5	80	28/28, 28/15, 26/26	50
38/17 10X20	30,5	20	38/17, 36/20, 35/50, 36/36	100
38/17 10X30	30,5	30	38/17, 36/20, 35/50, 36/36	100
38/17 10X40	30,5	40	38/17, 36/20, 35/50, 36/36	100
38/17 10X50	30,5	50	38/17, 36/20, 35/50, 36/36	100
38/17 10X60	30,5	60	38/17, 36/20, 35/50, 36/36	100
38/17 10X80	30,5	80	38/17, 36/20, 35/50, 36/36	50
38/17 10X100	30,5	100	38/17, 36/20, 35/50, 36/36	50
38/17 10X150	30,5	150	38/17, 36/20, 35/50, 36/36	50
38/17 12X20	30,5	20	38/17, 36/20, 35/50, 36/36	100
38/17 12X30	30,5	30	38/17, 36/20, 35/50, 36/36	100



¹⁾ geeignet für Profile

	Nennmaß	A	L	S ¹⁾	VPE
	38/17 12X40	30,5	40	38/17, 36/20, 35/50, 36/36	50
	38/17 12X50	30,5	50	38/17, 36/20, 35/50, 36/36	50
	38/17 12X60	30,5	60	38/17, 36/20, 35/50, 36/36	50
	38/17 12X80	30,5	80	38/17, 36/20, 35/50, 36/36	50
	38/17 12X100	30,5	100	38/17, 36/20, 35/50, 36/36	50
	38/17 12X125	30,5	125	38/17, 36/20, 35/50, 36/36	50
	38/17 12X150	30,5	150	38/17, 36/20, 35/50, 36/36	25
	38/17 12X200	30,5	200	38/17, 36/20, 35/50, 36/36	25
	38/17 16X30	30,5	30	38/17, 36/20, 35/50, 36/36	50
	38/17 16X40	30,5	40	38/17, 36/20, 35/50, 36/36	50
	38/17 16X50	30,5	50	38/17, 36/20, 35/50, 36/36	50
	38/17 16X60	30,5	60	38/17, 36/20, 35/50, 36/36	50
	38/17 16X80	30,5	80	38/17, 36/20, 35/50, 36/36	25
	38/17 16X100	30,5	100	38/17, 36/20, 35/50, 36/36	25
	38/17 16X125	30,5	125	38/17, 36/20, 35/50, 36/36	25
	38/17 16X150	30,5	150	38/17, 36/20, 35/50, 36/36	25
	38/17 16X200	30,5	200	38/17, 36/20, 35/50, 36/36	25
	40/22 10X20	32,5	20	40/22, 40/25	100
	40/22 10X30	32,5	30	40/22, 40/25	100
	40/22 10X40	32,5	40	40/22, 40/25	100
	40/22 10X50	32,5	50	40/22, 40/25	100
	40/22 10X60	32,5	60	40/22, 40/25	100
	40/22 10X80	32,5	80	40/22, 40/25	50
	40/22 10X100	32,5	100	40/22, 40/25	50
	40/22 12X20	32,5	20	40/22, 40/25	100
	40/22 12X30	32,5	30	40/22, 40/25	100
	40/22 12X40	32,5	40	40/22, 40/25	50
	40/22 12X50	32,5	50	40/22, 40/25	50
	40/22 12X60	32,5	60	40/22, 40/25	50
	40/22 12X80	32,5	80	40/22, 40/25	50
	40/22 12X100	32,5	100	40/22, 40/25	50
	40/22 12X125	32,5	125	40/22, 40/25	50

¹⁾ geeignet für Profile

Nennmaß	A	L	S ¹⁾	VPE
40/22 12X150	32,5	150	40/22, 40/25	50
40/22 12X200	32,5	200	40/22, 40/25	25
40/22 16X30	32,5	30	40/22, 40/25	50
40/22 16X40	32,5	40	40/22, 40/25	50
40/22 16X50	32,5	50	40/22, 40/25	50
40/22 16X60	32,5	60	40/22, 40/25	25
40/22 16X80	32,5	80	40/22, 40/25	25
40/22 16X100	32,5	100	40/22, 40/25	25
40/22 16X125	32,5	125	40/22, 40/25	25
40/22 16X150	32,5	150	40/22, 40/25	25
40/22 16X200	32,5	200	40/22, 40/25	25
40/22 16X250	32,5	250	40/22, 40/25	25
40/22 16X300	32,5	300	40/22, 40/25	25
50/30 10X30	41	30	52/34, 54/33, 50/30, 49/30, 50/40, 55/42	100
50/30 10X40	41	40	52/34, 54/33, 50/30, 49/30, 50/40, 55/42	100
50/30 10X50	41	50	52/34, 54/33, 50/30, 49/30, 50/40, 55/42	100
50/30 12X30	41	30	52/34, 54/33, 50/30, 49/30, 50/40, 55/42	100
50/30 12X40	41	40	52/34, 54/33, 50/30, 49/30, 50/40, 55/42	50
50/30 12X50	41	50	52/34, 54/33, 50/30, 49/30, 50/40, 55/42	50
50/30 12X60	41	60	52/34, 54/33, 50/30, 49/30, 50/40, 55/42	50
50/30 12X80	41	80	52/34, 54/33, 50/30, 49/30, 50/40, 55/42	50
50/30 12X100	41	100	52/34, 54/33, 50/30, 49/30, 50/40, 55/42	50
50/30 12X125	41	125	52/34, 54/33, 50/30, 49/30, 50/40, 55/42	50
50/30 12X150	41	150	52/34, 54/33, 50/30, 49/30, 50/40, 55/42	50



¹⁾ geeignet für Profile

	Nennmaß	A	L	S ¹⁾	VPE
	50/30 12X200	41	200	52/34, 54/33, 50/30, 49/30, 50/40, 55/42	50
	50/30 16X30	41	30	52/34, 54/33, 50/30, 49/30, 50/40, 55/42	50
	50/30 16X40	41	40	52/34, 54/33, 50/30, 49/30, 50/40, 55/42	50
	50/30 16X50	41	50	52/34, 54/33, 50/30, 49/30, 50/40, 55/42	50
	50/30 16X60	41	60	52/34, 54/33, 50/30, 49/30, 50/40, 55/42	50
	50/30 16X80	41	80	52/34, 54/33, 50/30, 49/30, 50/40, 55/42	25
	50/30 16X100	41	100	52/34, 54/33, 50/30, 49/30, 50/40, 55/42	25
	50/30 16X125	41	125	52/34, 54/33, 50/30, 49/30, 50/40, 55/42	25
	50/30 16X150	41	150	52/34, 54/33, 50/30, 49/30, 50/40, 55/42	25
	50/30 16X200	41	200	52/34, 54/33, 50/30, 49/30, 50/40, 55/42	25
	50/30 16X300	41	300	52/34, 54/33, 50/30, 49/30, 50/40, 55/42	25
	50/30 20X35	41	35	52/34, 54/33, 50/30, 49/30, 50/40, 55/42	25
	50/30 20X45	41	45	52/34, 54/33, 50/30, 49/30, 50/40, 55/42	25
	50/30 20X55	41	55	52/34, 54/33, 50/30, 49/30, 50/40, 55/42	25
	50/30 20X65	41	65	52/34, 54/33, 50/30, 49/30, 50/40, 55/42	25
	50/30 20X75	41	75	52/34, 54/33, 50/30, 49/30, 50/40, 55/42	25
	50/30 20X100	41	100	52/34, 54/33, 50/30, 49/30, 50/40, 55/42	25
	50/30 20X125	41	125	52/34, 54/33, 50/30, 49/30, 50/40, 55/42	25

¹⁾ geeignet für Profile

Nennmaß	A	L	S ¹⁾	VPE
50/30 20X150	41	150	52/34, 54/33, 50/30, 49/30, 50/40, 55/42	25
50/30 20X200	41	200	52/34, 54/33, 50/30, 49/30, 50/40, 55/42	10
50/30 20X300	41	300	52/34, 54/33, 50/30, 49/30, 50/40, 55/42	10

¹⁾ geeignet für Profile

20/12 28/15 38/17 41/22 50/30 72/48

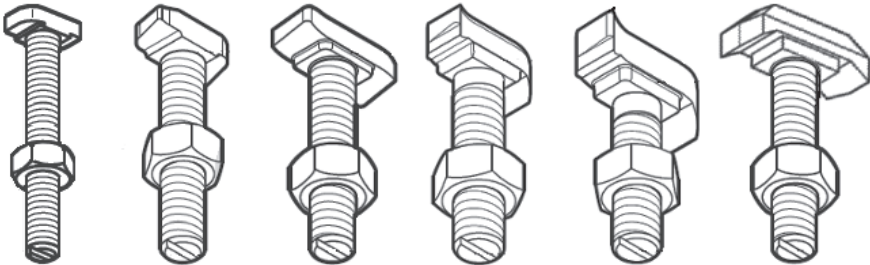

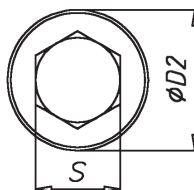
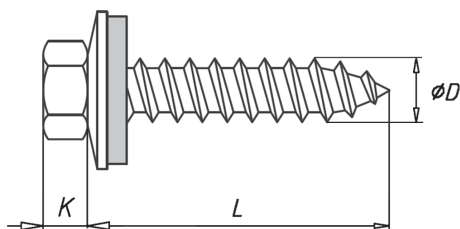

Maße in mm

FORM BZ:



FORM A:



Nennmaß	D2	K	S	VPE
BZ6,3x16	16	4,8	3/8"	500
BZ6,3x20	16	4,8	3/8"	500
BZ6,3x25	16	4,8	3/8"	200
BZ6,3x30	16	4,8	3/8"	200
BZ6,3x40	16	4,8	3/8"	200
BZ6,3x50	16	4,8	3/8"	200
BZ6,3x60	16	4,8	3/8"	200
BZ6,3x65	16	4,8	3/8"	100
BZ6,3x70	16	4,8	3/8"	100
BZ6,3x75	16	4,8	3/8"	100
BZ6,3x80	16	4,8	3/8"	100
BZ6,3x85	16	4,8	3/8"	100
BZ6,3x90	16	4,8	3/8"	100
BZ6,3x100	16	4,8	3/8"	100
BZ6,3x115	16	4,8	3/8"	100
BZ6,3x130	16	4,8	3/8"	100
BZ6,3x150	16	4,8	3/8"	100
BZ6,3x175	16	4,8	3/8"	100
BZ6,3x200	16	4,8	3/8"	100

Nennmaß	D2	K	S	VPE
A6,5x16	16	4,8	3/8"	500
A6,5x20	16	4,8	3/8"	500
A6,5x25	16	4,8	3/8"	200
A6,5x30	16	4,8	3/8"	200
A6,5x40	16	4,8	3/8"	200
A6,5x45	16	4,8	3/8"	200
A6,5x50	16	4,8	3/8"	200
A6,5x60	16	4,8	3/8"	200
A6,5x64	16	4,8	3/8"	100
A6,5x70	16	4,8	3/8"	100
A6,5x75	16	4,8	3/8"	100
A6,5x85	16	4,8	3/8"	100
A6,5x90	16	4,8	3/8"	100
A6,5x100	16	4,8	3/8"	100
A6,5x115	16	4,8	3/8"	100
A6,5x130	16	4,8	3/8"	100
A6,5x150	16	4,8	3/8"	100
A6,5x175	16	4,8	3/8"	100
A6,5x200	16	4,8	3/8"	100

Fassadenbauschrauben mit vormontierter Edelstahl EPDM-Dichtscheibe. Ausführung K160 Schraube in Stahl, verzinkt. Ausführung KX160 mit Schraube aus Edelstahl.

Form A: Für Holzunterkonstruktionen Form: BZ: für Stahlunterkonstruktionen

Maße in mm

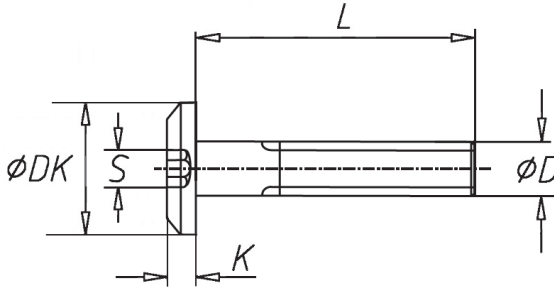

Nennmaß ¹⁾	DK	K	S	VPE
KF 5X15	15	2	4	100
KF 5X25	15	2	4	100
KF 5X30	15	2	4	100
KF 5X40	15	2	4	100
KF 6X12	15	2,5	4	100
KF 6X16	15	2,5	4	100
KF 6X20	15	2,5	4	100
KF 6X25	15	2,5	4	100
KF 6X30	15	2,5	4	100
KF 6X35	15	2,5	4	100
KF 6X40	15	2,5	4	100
KF 6X45	15	2,5	4	100
KF 6X50	15	2,5	4	100

Nennmaß ¹⁾	DK	K	S	VPE
KF 6X60	15	2,5	4	100
KF 6X70	15	2,5	4	100
KF 6X80	15	2,5	4	100
KF 6X90	15	2,5	4	100
KF 6X100	15	2,5	4	100
KF 6X110	15	2,5	4	100
KF 6X120	15	2,5	4	100
KF 8X16	17	2,8	5	100
KF 8X25	17	2,8	5	100
KF 8X40	17	2,8	5	100
KF 8X45	17	2,8	5	100
KF 8X50	17	2,8	5	100

Mit Innensechskant und dekorativem Kopf für sichtbare Verbindungen.

Lieferbar in: Güte 4.8 und Edelstahl

¹⁾ KF D X L



Maße in mm

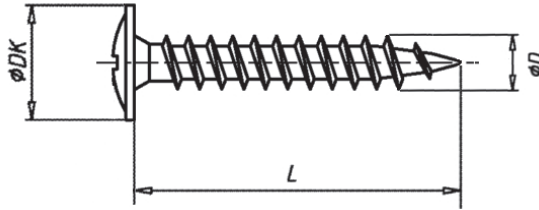

D	3	3,5	4
DK	8	8,2	9,2
BIT	PZ 1	PZ 2	PZ 2

Maße vorbehaltlich produktionsbedingter Änderungen.

VPE

L \ D	3	3,5	4
17	–	–	1000
20	1000	1000	–
25	1000	1000	1000
30	1000	1000	1000
35	1000	–	500
40	–	–	500

Die handelsüblichen Größen sind durch Angabe der VPE gekennzeichnet.

Maße in mm

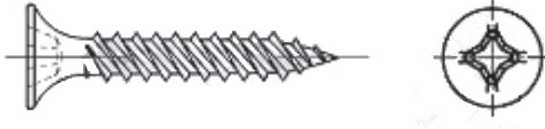

1



2



3



4



5



6



7



8



9



Nennmaß	BIT	VPE
3,5x25	PH 2	1000
3,5x35	PH 2	1000
3,5x45	PH 2	1000
3,9x19	PH 2	1000
3,9x25	PH 2	1000
3,9x30	PH 2	1000
3,9x35	PH 2	1000
3,9x45	PH 2	1000
3,9x55	PH 2	1000
4,2x55	PH 2	500
4,2x65	PH 2	500
4,2x75	PH 2	500
4,8x90	PH 2	500
5,5x70	PH 2	500
5,5x80	PH 2	500
5,5x90	PH 2	500
5,5x100	PH 2	500

Schnellbauschrauben mit Trompeten-Senkkopf, Doppelgang-Feingewinde, selbstzentrierender Schraubspitze, gehärtet und schwarz phosphatiert. Geeignet für die Befestigung von Gipskartonplatten auf Metallständerwerk.

Bei nicht genormten Teilen können die angegebenen Maße herstellungsbedingt abweichen.



Maße in mm

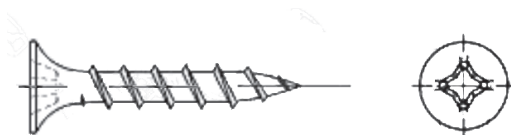

Nennmaß	BIT	VPE
3,9x25 GG	PH 2	1000
3,9x35 GG	PH 2	1000
3,9x45 GG	PH 2	1000
3,9x55 GG	PH 2	1000
4,2x65 GG	PH 2	500
4,2x75 GG	PH 2	500

Schnellbauschrauben mit Trompeten-Senkopf, Grobgewinde, gehärtet und schwarz phosphatiert. Geeignet für die Befestigung von Gipskartonplatten auf Holzunterkonstruktion.

Bei nicht genormten Teilen können die angegebenen Maße herstellungsbedingt abweichen.

Maße in mm

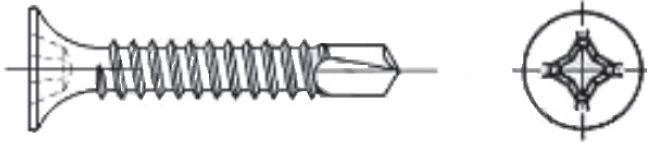

Nennmaß	BIT	VPE	Nennmaß	BIT	VPE
3,5x25 BSP	PH 2	1000	3,5x45 BSP	PH 2	1000
3,5x35 BSP	PH 2	1000	3,5x55 BSP	PH 2	1000

Schnellbauschrauben mit Trompeten-Senkkopf, TEKS Bohrspitze, gehärtet und schwarz phosphatiert. Geeignet für die Befestigung von Gipskartonplatten auf Metallständerwerk (bis 2,0 mm) ohne vorzubohren.

Bei nicht genormten Teilen können die angegebenen Maße herstellungsbedingt abweichen.





Maße in mm

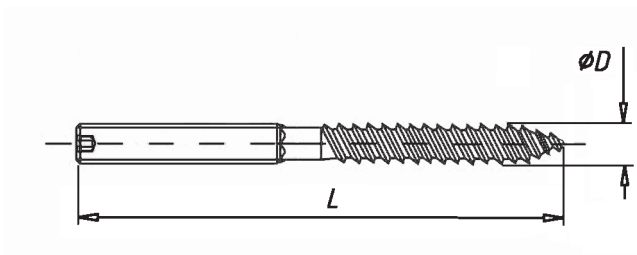

Nennmaß	VPE	Nennmaß	VPE
6x50	100	10x50	100
6x60	100	10x60	100
6x70	100	10x70	100
6x80	100	10x80	100
6x90	100	10x90	100
6x100	100	10x100	50
6x120	100	10x120	50
8x50	100	10x140	50
8x60	100	10x160	50
8x70	100	10x180	50
8x80	100	10x200	50
8x90	100	10x220	50
8x100	100	12x100	50
8x110	100	12x120	50
8x120	100	12x140	50
8x130	100	12x160	50
8x140	100	12x180	50
8x150	100	12x200	50
8x160	100	12x220	50
8x180	100	12x240	50
8x200	100	12x260	50

Die Stockschraube besitzt ein metrisches Gewinde, sowie ein Holzgewinde und eignet sich besonders zur Abstandsmontage. Lieferbar in Stahl sowie Edelstahl A2

Maße in mm

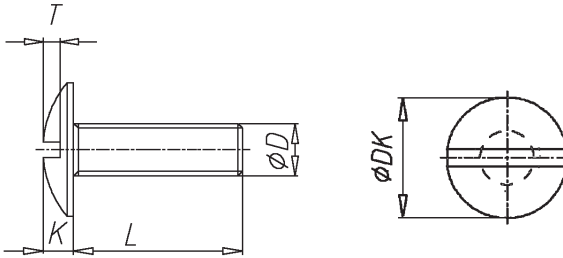

D	M4	M5	M6	M8	M10
P ¹⁾	0,7	0,8	1	1,25	1,5
DK	10	12	14	17	20
K	3	4	4,2	4,4	6
T	1,5	1,9	2	2,7	3

¹⁾ Gewindesteigung

Bei nicht genormten Teilen können die angegebenen Maße herstellungsbedingt abweichen.

VPE

L \ D	M4	M5	M6	M8	M10
6	100	–	–	–	–
8	100	100	100	–	–
10	100	100	100	–	–
12	100	100	100	100	–
16	100	100	100	100	–
20	100	100	100	100	200
25	–	100	100	100	200
30	100	100	100	100	200
35	–	–	100	100	–
40	–	100	100	100	100
45	–	–	100	100	100
50	–	100	100	100	100
60	–	–	100	100	100
70	–	–	–	100	–
80	–	–	–	100	–

Die handelsüblichen Größen sind durch Angabe der VPE gekennzeichnet.
Lieferbar in Stahl sowie Edelstahl A2





Maße in mm

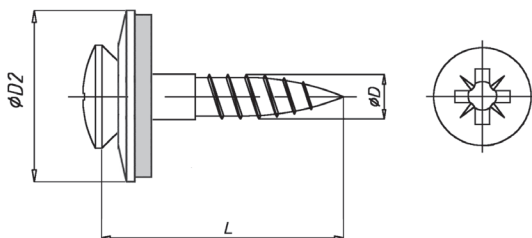

Nennmaß	D	D2	L	BIT	VPE
4,5x20	4,5	20	20	Z2	200
4,5x25	4,5	20	25	Z2	200
4,5x30	4,5	20	30	Z2	200
4,5x35	4,5	20	35	Z2	200
4,5x40	4,5	20	40	Z2	200
4,5x45	4,5	20	45	Z2	200
4,5x50	4,5	20	50	Z2	200
4,5x55	4,5	20	55	Z2	200
4,5x60	4,5	20	60	Z2	200
4,5x80	4,5	20	80	Z2	200
4,5x100	4,5	20	100	Z2	200

Weitere Scheibendurchmesser lieferbar.
 Lieferbar in Edelstahl A2

Maße in mm

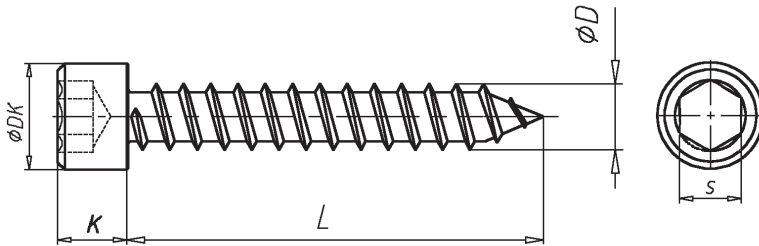

D	4,8	5,5	6,3
DK	8,5	10	10
K	4,8	6	6
S	4	5	5

VPE

L \ D	4,8	5,5	6,3
13	1000	1000	–
16	1000	–	–
19	1000	1000	1000
22	1000	1000	–
25	1000	1000	1000
32	1000	1000	1000
38	1000	1000	1000
45	1000	1000	1000
50	1000	1000	1000
55	1000	1000	–
60	1000	1000	1000
65	–	500	–
70	500	500	500
80	–	500	500
90	–	500	500
100	–	500	–

Die handelsüblichen Größen sind durch Angabe der VPE gekennzeichnet.
Lagerhaltig in Edelstahl A2



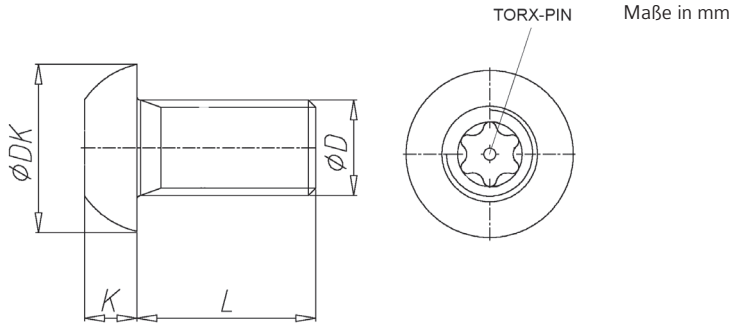

D	M3	M4	M5	M6	M8	M10
DK	5,7	7,6	9,5	10,5	14	17,5
K	1,7	2,2	2,8	3,3	4,4	5,5
BIT	T-10H	T-20H	T-25H	T-30H	T-40H	T-45H

VPE

L \ D	M3	M4	M5	M6	M8	M10
6	100	100	-	-	-	-
8	100	100	100	-	-	-
10	100	100	100	-	100	-
12	100	100	100	100	100	-
16	100	100	100	100	100	100
20	100	100	100	100	100	100
25	-	100	100	100	100	100
30	-	100	100	100	100	100
35	-	100	100	100	100	-
40	-	100	100	100	100	100
50	-	100	100	100	100	100
60	-	-	100	100	100	100
70	-	-	-	-	-	100

Auch mit Innensechskant-Pin lieferbar.
Die handelsüblichen Größen sind durch Angabe der VPE gekennzeichnet.
Lieferbar in Edelstahl A2

Maße in mm

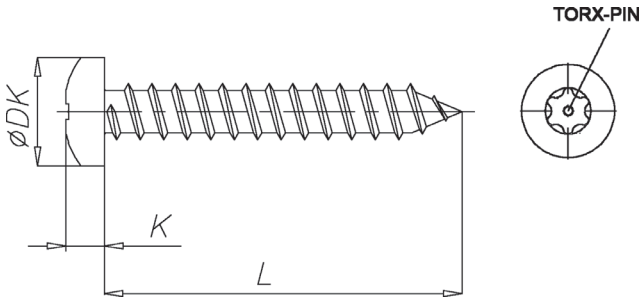

D	3,5	4,2	4,8	5,5	6,3
DK	6,7	7,9	9,2	10,5	11,1
K	1,9	2,2	2,6	2,9	3,4
BIT	T-10H	T-20H	T-25H	T-30H	T-30H

VPE

L \ D	3,5	4,2	4,8	5,5	6,3
13	100	100	100	100	100
16	100	–	–	–	–
19	100	100	100	100	100
25	–	100	100	100	100
32	–	100	100	100	100
38	–	100	100	100	100
50	–	–	100	100	100

Auch mit Innensechskant-Pin lieferbar.

Die handelsüblichen Größen sind durch Angabe der VPE gekennzeichnet.

Lieferbar in Edelstahl A2



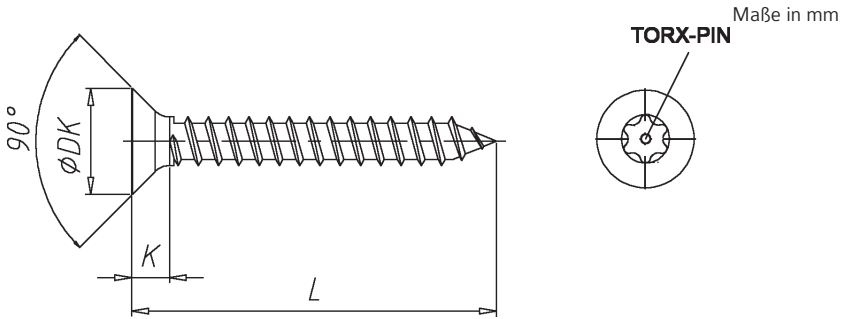

D	3,5	4,2	4,8	5,5
DK	7,8	9,1	10,5	11,1
K	3,3	3,8	4,3	4,4
BIT	T-15H	T-20H	T-25H	T-30H

VPE

L \ D	3,5	4,2	4,8	5,5
13	100	100	100	-
19	100	100	100	100
25	100	100	100	100
32	100	100	100	100
38	100	100	100	100
50	-	-	100	100
63	-	-	-	100
75	-	-	-	100

Auch mit Innensechskant-Pin lieferbar.
 Die handelsüblichen Größen sind durch Angabe der VPE gekennzeichnet.
 Lieferbar in Edelstahl A2

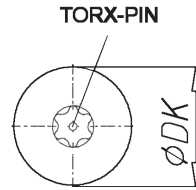
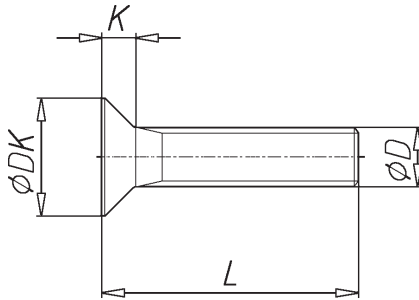

Maße in mm

D	M3	M4	M5	M6
DK	6	8	10	12
K	1,7	2,3	2,8	3,3
BIT	T-10H	T-20H	T-25H	T-30H

VPE

L \ D	M3	M4	M5	M6
6	100	200	–	–
8	100	200	200	–
10	200	200	200	100
12	200	200	100	200
16	100	100	100	100
20	100	200	100	100
25	–	100	100	100
30	–	100	100	100
40	–	100	100	100
50	–	200	100	200
60	–	–	100	200
70	–	–	100	–

Auch mit Innensechskant-Pin lieferbar.
 Die handelsüblichen Größen sind durch Angabe der VPE gekennzeichnet.
 Lieferbar in Edelstahl A2





Maße in mm

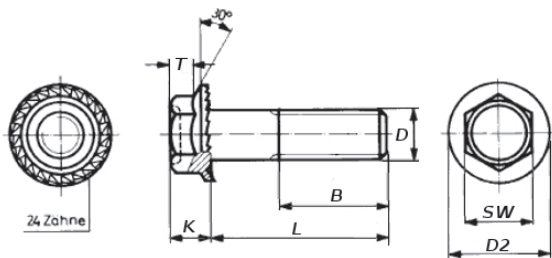

D	M5	M6	M8	M10	M12	M16
D2	11,2	14,2	18,2	21	24	31
K max.	4,3	5,5	7	7,9	8,7	11,2
SW	8	10	13	15	17	22
T	3	3,8	5	5,6	5,9	7,4

Die Sicherungsschrauben ermöglichen hohe Vorspannkraft - ein zusätzlicher Schutz gegen Lockern und Losdrehen. Die Sicherung erfolgt durch 24 Verriegelungszähne. Da sich die Zähne um die Zahntiefe in das Gegenmaterial eingraben, ist hier eine gewisse Oberflächenbeschädigung im Bereich der Zähne gegeben, insbesondere wenn die Schraube wieder gelöst wird, da dann das Material um die Eindringtiefe der Zähne abgefräst wird. Sofern Sie eine Oberflächenbeschädigung vermeiden müssen, empfehlen wir Ihnen in solchen Fällen die Sicherungsschraube.

VPE

L \ D	M5	M6	M8	M10	M12	M16
8	200	–	–	–	–	–
10	200	200	–	–	–	–
12	200	200	200	–	–	–
14	200	200	200	–	–	–
16	200	200	200	100	–	–
20	200	200	200	100	100	–
25	–	200	200	100	100	50
30	–	200	200	100	50	50
35	–	–	200	100	50	50
40	–	–	200	100	50	50
45	–	–	–	–	–	50
50	–	–	–	–	50	50
55	–	–	–	–	–	50
60	–	–	–	–	–	50
70	–	–	–	–	–	50

Die handelsüblichen Größen sind durch Angabe der VPE gekennzeichnet.
Lieferbar in Stahl Güte: 90, 100

Festigkeitsklasse 90: einsatzvergütet, Randhärte 400-550 HV1 $R_m = 900-1100 \text{ N/mm}^2$, $R_{p0,2} = 720 \text{ N/mm}^2$
Festigkeitsklasse 100: einsatzvergütet, Randhärte 400-550 HV1 $R_m = 1040-1200 \text{ N/mm}^2$, $R_{p0,2} = 830 \text{ N/mm}^2$





Maße in mm

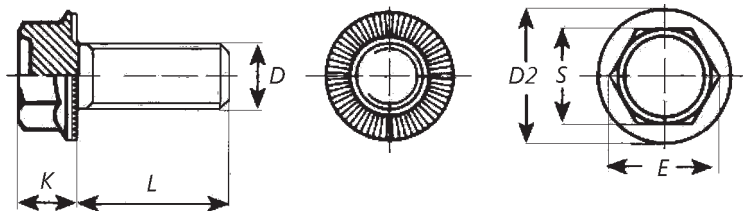

D	M5	M6	M8	M10	M12	M16
D2	11,2	14,2	18,2	21	24	31
K	4,3	5,5	7,0	8,5	10	14
S	8	10	13	15	17	22
E	8,87	11,05	14,38	16,64	18,90	24,49

Statt herkömmlicher Sperrzähne hat die Sicherungsschraube gerundete Rippen. Vorteile sind: 1. Verschraubung auf rauen Oberflächen. 2. Keine Spanbildung möglich. 3. Weitgehende Erhaltung des Korrosionsschutzes an der Verbindungsstelle 4. Ausgezeichnete Sicherungswirkung auf harten Werkstoffen 5. Keine Kerbwirkung bei der Verschraubung dünner Bleche 6. Keine Unterlegscheiben nötig

VPE

L \ D	M5	M6	M8	M10	M12	M16
10	500	500	–	–	–	–
12	500	500	200	–	–	–
16	500	500	200	100	–	–
20	500	500	200	100	100	–
25	–	500	200	100	100	50
30	–	500	200	100	100	50
35	–	–	200	100	100	50
40	–	–	200	100	100	50
45	–	–	–	–	100	50
50	–	–	–	–	100	50
55	–	–	–	–	–	50
60	–	–	–	–	100	50
70	–	–	–	–	–	50

Die handelsüblichen Größen sind durch Angabe der VPE gekennzeichnet.
Lieferbar in Stahl Güte: 100

Festigkeitsklasse 100: einsatzvergütet, Randhärte 400-550 HV1 $R_m=1040-1200 \text{ N/mm}^2$, $R_{p0,2} = 830 \text{ N/mm}^2$

Maße in mm

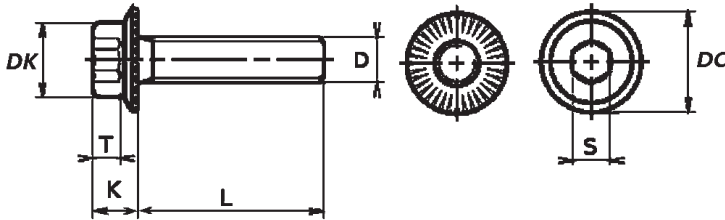

D1	M5	M6	M8	M10	M12
DK	9	11	14	17	19
DC	11	13,5	17	19,5	22,5
K	5	6	8	10	12
S	4	5	6	8	10
T	2,5	3	4	5	6

Statt herkömmlicher Sperrzähne hat die Inbus-Ripp Sicherungsschraube gerundete Rippen. Vorteile sind: 1. Verschraubung auf rauen Oberflächen. 2. Keine Spanbildung möglich. 3. Weitgehende Erhaltung des Korrosionsschutzes an der Verbindungsstelle 4. Ausgezeichnete Sicherungswirkung auf harten Werkstoffen 5. Keine Kerbwirkung bei der Verschraubung dünner Bleche 6. Keine Unterlegscheiben nötig

VPE

L \ D	M5	M6	M8	M10	M12
10	200	200	–	–	–
12	200	200	200	–	–
16	200	200	200	–	–
20	200	200	200	100	100
25	–	200	200	100	100
30	–	200	200	100	100
35	–	–	–	100	100
40	–	–	200	100	100
45	–	–	–	–	100
50	–	–	–	–	100

Die handelsüblichen Größen sind durch Angabe der VPE gekennzeichnet.
Lieferbar in Stahl Güte: 100

Festigkeitsklasse 100: einsatzvergütet, Randhärte 400-550 HV1 $R_m = 1040-1200 \text{ N/mm}^2$, $R_{p0,2} = 830 \text{ N/mm}^2$



Maße in mm

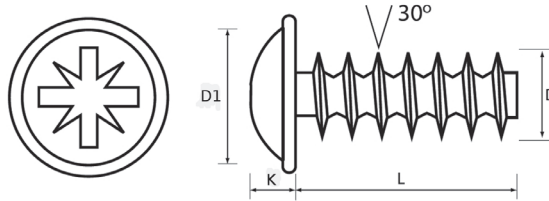

D	2,2	2,5	3	3,5	4	5	6
D1	4,4	5	6	7	8	10	12
K	1,6	1,8	2,1	2,4	2,5	3,2	4

Bei nicht genormten Teilen können die angegebenen Maße herstellungsbedingt abweichen.

VPE

L \ D	2,2	2,5	3	3,5	4	5	6
5	1000	1000	–	–	–	–	–
6	1000	1000	1000	–	–	–	–
8	1000	1000	1000	1000	1000	–	–
10	1000	1000	1000	1000	1000	–	–
12	–	1000	1000	1000	1000	1000	1000
14	–	–	1000	1000	1000	1000	–
16	–	–	1000	1000	1000	1000	500
18	–	–	–	1000	1000	1000	–
20	–	–	1000	1000	1000	500	500
25	–	–	–	1000	1000	500	500
30	–	–	–	–	500	500	500

Die handelsüblichen Größen sind durch Angabe der VPE gekennzeichnet.
Lieferbar in Stahl (380 HV) sowie Edelstahl A2

Maße in mm

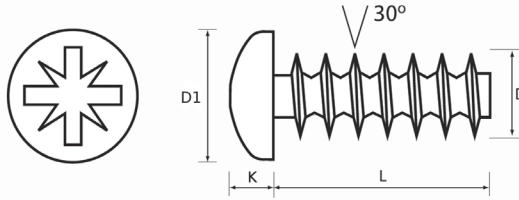

D	2,2	2,5	3	3,5	4	5	6
D1	3,9	4,4	5,3	6,1	7	8,8	10,5
K	1,5	1,7	2	2,5	2,7	3,4	4

Bei nicht genormten Teilen können die angegebenen Maße herstellungsbedingt abweichen.

VPE

L \ D	2,2	2,5	3	3,5	4	5	6
5	1000	1000	1000	–	–	–	–
6	1000	1000	1000	–	–	–	–
8	1000	1000	1000	1000	1000	–	–
10	1000	1000	1000	1000	1000	1000	–
12	–	1000	1000	1000	1000	1000	1000
14	–	1000	1000	1000	1000	–	–
16	–	1000	1000	1000	1000	1000	1000
18	–	–	1000	1000	1000	–	–
20	–	–	1000	1000	1000	500	500
25	–	–	1000	1000	1000	500	500
30	–	–	1000	1000	1000	500	500
35	–	–	–	–	–	–	500

Die handelsüblichen Größen sind durch Angabe der VPE gekennzeichnet.
Lieferbar in Stahl (380 HV) sowie Edelstahl A2





Maße in mm

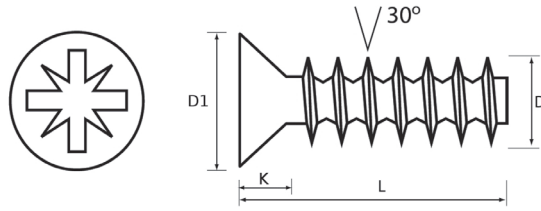

D	2,2	2,5	3	3,5	4	5	6
D1	3,8	4,7	5,5	7,3	8,4	9,3	11,3
K	1,3	1,75	2,05	2,8	3,25	3,4	3,8

Bei nicht genormten Teilen können die angegebenen Maße herstellungsbedingt abweichen.

VPE

L \ D	2,2	2,5	3	3,5	4	5	6
5	1000	–	–	–	–	–	–
6	1000	1000	1000	–	–	–	–
8	1000	1000	1000	1000	1000	–	–
10	1000	1000	1000	1000	1000	–	–
12	–	1000	1000	1000	1000	1000	1000
14	–	1000	1000	1000	1000	1000	–
16	–	1000	1000	1000	1000	1000	1000
18	–	–	1000	1000	1000	1000	–
20	–	–	1000	1000	1000	1000	500
25	–	–	1000	1000	1000	1000	500
30	–	–	–	–	1000	500	500

Die handelsüblichen Größen sind durch Angabe der VPE gekennzeichnet.
Lieferbar in Stahl (380 HV) sowie Edelstahl A2

Maße in mm

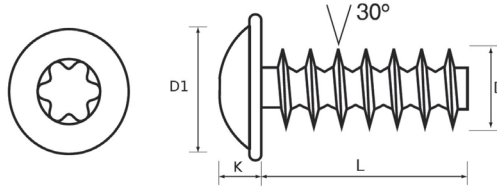

D	3	3,5	4	5	6
D1	6	7	8	10	12
K	2,1	2,4	2,6	3,3	3,6

Bei nicht genormten Teilen können die angegebenen Maße herstellungsbedingt abweichen.

VPE

L \ D	3	3,5	4	5	6
6	1000	–	–	–	–
8	1000	100	1000	1000	–
10	1000	8000	1000	1000	–
12	1000	1000	2000	1000	500
14	1000	1000	6000	1000	500
16	1000	1000	1000	1000	500
18	–	1000	–	1000	500
20	1000	1000	1000	1000	500
25	1000	1000	1000	1000	500
30	–	–	1000	1000	500

Die handelsüblichen Größen sind durch Angabe der VPE gekennzeichnet.
Lieferbar in Stahl (380 HV) sowie Edelstahl A2





Maße in mm

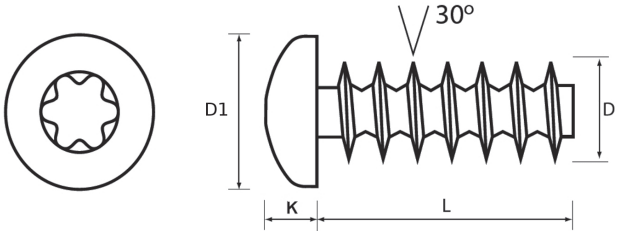

D	2,5	3	3,5	4	5
D1	4,2	5,6	6,9	7,5	8,2
K	1,6	2,1	2,3	2,6	2,9

Bei nicht genormten Teilen können die angegebenen Maße herstellungsbedingt abweichen.

VPE

L \ D	2,5	3	3,5	4	5
6	1000	1000	–	–	–
8	1000	1000	1000	1000	–
10	1000	1000	1000	1000	–
12	1000	1000	1000	1000	–
14	1000	1000	1000	1000	–
16	1000	1000	1000	1000	1000
18	–	1000	1000	–	–
20	–	1000	1000	1000	1000
25	–	–	1000	1000	1000
30	–	–	–	–	1000

Die handelsüblichen Größen sind durch Angabe der VPE gekennzeichnet.
Lieferbar in Stahl (380 HV) sowie Edelstahl A2

Maße in mm

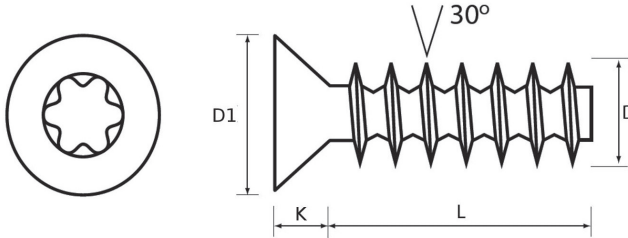

D	2,5	3	3,5	4	5	6
D1	4,7	5,5	7,3	8,4	9,3	11,3
K	1,75	2,05	2,8	3,25	3,4	3,8

Bei nicht genormten Teilen können die angegebenen Maße herstellungsbedingt abweichen.

VPE

L \ D	2,5	3	3,5	4	5	6
6	1000	–	–	–	–	–
8	1000	1000	–	–	–	–
10	1000	1000	1000	1000	–	–
12	1000	1000	1000	1000	–	–
16	–	1000	1000	1000	1000	500
20	–	–	1000	1000	1000	500

Die handelsüblichen Größen sind durch Angabe der VPE gekennzeichnet.
Lieferbar in Stahl (380 HV) sowie Edelstahl A2





Maße in mm

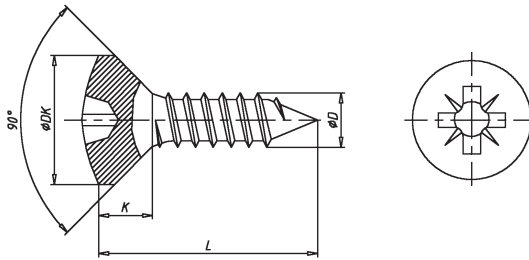

D	3	3,5	4	4,5	5	6
DK	6	7	8	9	10	12
K	1,8	2	2,35	2,55	2,85	3,35
BIT	PZ 1	PZ 2	PZ 2	PZ 2	PZ 2	PZ 3

Bei nicht genormten Teilen können die angegebenen Maße herstellungsbedingt abweichen.

VPE

L \ D	3	3,5	4	4,5	5	6
12	1000	1000	-	-	-	-
16	1000	1000	1000	1000	-	-
20	1000	1000	1000	1000	500	-
25	1000	1000	1000	1000	500	-
30	1000	1000	1000	1000	500	-
35	-	1000	1000	500	500	-
40	-	1000	500	500	500	200
45	-	-	500	500	200	200
50	-	-	500	500	200	200
60	-	-	-	200	200	200
80	-	-	-	-	-	200

Die handelsüblichen Größen sind durch Angabe der VPE gekennzeichnet.
Lieferbar in Stahl sowie Edelstahl A2

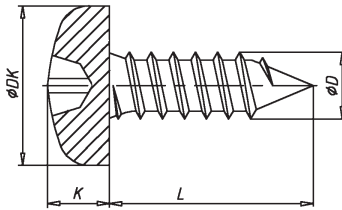

Maße in mm

D	3	3,5	4	4,5	5	6
DK	6	7	8	9	10	12
K	2,25	2,6	2,8	3	3,5	4,1
BIT	PZ 1	PZ 2	PZ 2	PZ 2	PZ 2	PZ 3

Bei nicht genormten Teilen können die angegebenen Maße herstellungsbedingt abweichen.

VPE

L \ D	3	3,5	4	4,5	5	6
10	1000	1000	–	–	–	–
12	1000	1000	1000	–	–	–
15	1000	1000	1000	–	–	–
16	1000	1000	1000	1000	1000	–
20	1000	1000	1000	1000	1000	–
25	1000	1000	1000	1000	500	200
30	1000	1000	1000	1000	500	200
35	–	1000	500	500	500	200
40	–	500	500	500	500	200
45	–	–	500	500	200	200
50	–	–	500	500	200	200
60	–	–	500	500	200	200
70	–	–	–	–	200	200
80	–	–	–	–	200	100
90	–	–	–	–	–	100
100	–	–	–	–	–	100
120	–	–	–	–	–	100

Die handelsüblichen Größen sind durch Angabe der VPE gekennzeichnet.
Lieferbar in Stahl sowie Edelstahl A2





Maße in mm

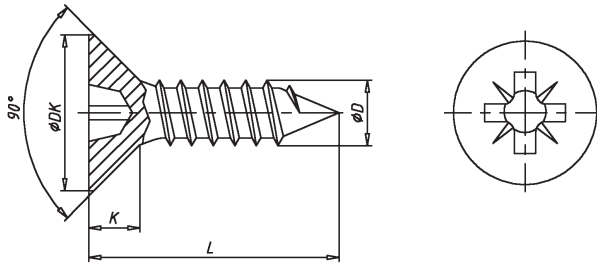

D	3	3,5	4	4,5	5	6
DK	6	7	8	9	10	12
K	1,8	2	2,35	2,55	2,85	3,35
BIT	PZ 1	PZ 2	PZ 2	PZ 2	PZ 2	PZ 3

Bei nicht genormten Teilen können die angegebenen Maße herstellungsbedingt abweichen.

VPE

L \ D	3	3,5	4	4,5	5	6
10	1000	–	–	–	–	–
12	1000	1000	1000	–	–	–
16	1000	1000	1000	1000	1000	–
20	1000	1000	1000	1000	1000	–
25	1000	1000	1000	1000	1000	–
30	1000	1000	1000	1000	500	500
35	1000	1000	1000	500	500	500
40	1000	1000	1000	500	500	200
45	–	1000	500	500	500	200
50	–	500	500	500	500	200
55	–	–	500	500	500	200
60	–	–	500	500	200	200
70	–	–	200	200	200	200
80	–	–	–	200	200	200
90	–	–	–	–	200	100
100	–	–	–	–	200	100
110	–	–	–	–	–	100
120	–	–	–	–	100	100
130	–	–	–	–	–	100
140	–	–	–	–	–	100
150	–	–	–	–	–	100
160	–	–	–	–	–	100
180	–	–	–	–	–	100
190	–	–	–	–	–	100
200	–	–	–	–	–	100

Die handelsüblichen Größen sind durch Angabe der VPE gekennzeichnet.
Lieferbar in Stahl sowie Edelstahl A2





Maße in mm

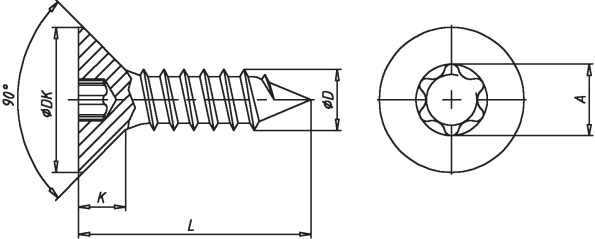

D	3	3,5	4	4,5	5	6
A	T10	T15	T20	T25	T25	T30
DK	6	7	8	9	10	12
K	1,8	2	2,35	2,55	2,85	3,35

Bei nicht genormten Teilen können die angegebenen Maße herstellungsbedingt abweichen.

VPE

L \ D	3	3,5	4	4,5	5	6
12	1000	–	–	–	–	–
16	1000	1000	1000	–	–	–
20	1000	1000	1000	1000	1000	–
25	1000	1000	1000	1000	1000	–
30	1000	1000	1000	1000	500	500
35	1000	1000	1000	500	500	500
40	1000	1000	1000	500	500	200
45	–	500	500	500	500	–
50	–	500	500	500	500	200
55	–	–	500	500	500	–
60	–	–	500	200	200	200
70	–	–	200	200	200	200
80	–	–	–	200	200	200
90	–	–	–	–	200	100
100	–	–	–	–	200	100
110	–	–	–	–	–	100
120	–	–	–	–	–	100
130	–	–	–	–	–	100
140	–	–	–	–	–	100
150	–	–	–	–	–	100
160	–	–	–	–	–	100
180	–	–	–	–	–	100
200	–	–	–	–	–	100
220	–	–	–	–	–	100
240	–	–	–	–	–	100
280	–	–	–	–	–	100

Die handelsüblichen Größen sind durch Angabe der VPE gekennzeichnet.
Lieferbar in Stahl sowie Edelstahl A2





Maße in mm

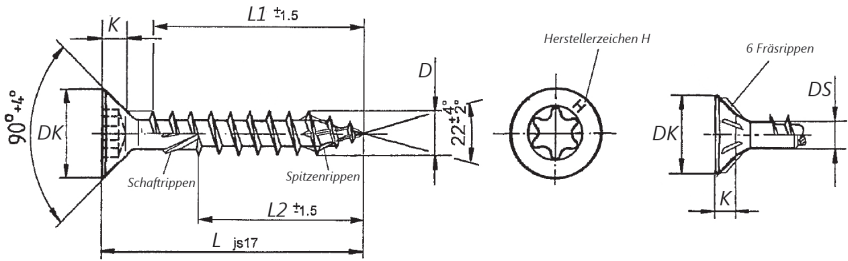

Nennmaß	D	DK	DS min.	K max.	L	L1 ¹⁾	VPE
3,5X20 VG T15	3,5	7	2,45	2,1	20	16	1000
3,5X25 VG T15	3,5	7	2,45	2,1	25	21	1000
3,5X30 VG T15	3,5	7	2,45	2,1	30	26	1000
3,5X35 VG T15	3,5	7	2,45	2,1	35	31	1000
3,5X40 VG T15	3,5	7	2,45	2,1	40	36	500
3,5X45 VG T15	3,5	7	2,45	2,1	45	41	500
3,5X50 VG T15	3,5	7	2,45	2,1	50	46	500
4X25 VG T15	4	8	2,75	2,5	25	20	1000
4X30 VG T15	4	8	2,75	2,5	30	25	1000
4X35 VG T15	4	8	2,75	2,5	35	30	500
4X40 VG T15	4	8	2,75	2,5	40	35	500
4X45 VG T15	4	8	2,75	2,5	45	40	500
4X50 VG T15	4	8	2,75	2,5	50	45	500
4X55 VG T15	4	8	2,75	2,5	55	50	500
4X60 VG T15	4	8	2,75	2,5	60	54	200
4,5X25 VG T25	4,5	9	3,1	2,7	25	20	500
4,5X30 VG T25	4,5	9	3,1	2,7	30	24	500
4,5X35 VG T25	4,5	9	3,1	2,7	35	29	500
4,5X40 VG T25	4,5	9	3,1	2,7	40	34	500
4,5X45 VG T25	4,5	9	3,1	2,7	45	39	500
4,5X50 VG T25	4,5	9	3,1	2,7	50	44	200
4,5X55 VG T25	4,5	9	3,1	2,7	55	49	200
4,5X60 VG T25	4,5	9	3,1	2,7	60	54	200

¹⁾ Gewindelänge

Nennmaß	D	DK	DS min.	K max.	L	L1 ¹⁾	VPE
4,5X65 VG T25	4,5	9	3,1	2,7	65	60	200
4,5X70 VG T25	4,5	9	3,1	2,7	70	60	200
5X25 VG T25	5	9,7	3,45	3	25	20	200
5X30 VG T25	5	9,7	3,45	3	30	24	200
5X35 VG T25	5	9,7	3,45	3	35	29	200
5X40 VG T25	5	9,7	3,45	3	40	34	200
5X45 VG T25	5	9,7	3,45	3	45	39	200
5X50 VG T25	5	9,7	3,45	3	50	44	200
5X55 VG T25	5	9,7	3,45	3	55	49	200
5X60 VG T25	5	9,7	3,45	3	60	54	200
5X65 VG T25	5	9,7	3,45	3	65	60	200
5X70 VG T25	5	9,7	3,45	3	70	60	200
5X75 VG T25	5	9,7	3,45	3	75	60	200
5X80 VG T25	5	9,7	3,45	3	80	60	200
6X30 VG T25	6	11,8	4,2	3,6	30	24	200
6X35 VG T25	6	11,8	4,2	3,6	35	28	200
6X40 VG T25	6	11,8	4,2	3,6	40	33	200
6X45 VG T25	6	11,8	4,2	3,6	45	38	200
6X50 VG T25	6	11,8	4,2	3,6	50	43	200
6X55 VG T25	6	11,8	4,2	3,6	55	48	200
6X60 VG T25	6	11,8	4,2	3,6	60	53	200
6X65 VG T25	6	11,8	4,2	3,6	65	58	200
6X70 VG T25	6	11,8	4,2	3,6	70	60	200

Revolutionäre Spitzen- und Schaftgeometrie - Ansetzen, schrauben und fertig - Kein Vorbohren notwendig - Schnelleres Einschrauben - Deutliche Reduzierung der Spaltwirkung - Geringes Einschraubdrehmoment - Hohe Wirtschaftlichkeit - mit bauaufsichtlicher Zulassung

¹⁾ Gewindelänge





Maße in mm

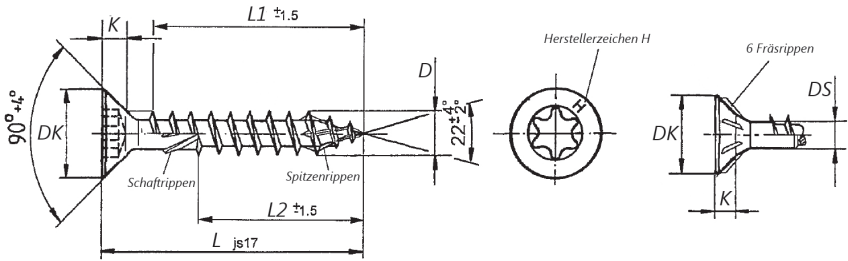

Nennmaß	D	DK	DS min.	K max.	L	L2 ²⁾	VPE
3,5X30 TG T15	3,5	7	2,45	2,1	30	18	1000
3,5X35 TG T15	3,5	7	2,45	2,1	35	21	500
3,5X40 TG T15	3,5	7	2,45	2,1	40	24	500
3,5X45 TG T15	3,5	7	2,45	2,1	45	27	500
3,5X50 TG T15	3,5	7	2,45	2,1	50	31	500
4X30 TG T15	4	8	2,75	2,5	30	20	1000
4X35 TG T15	4	8	2,75	2,5	35	20	500
4X40 TG T15	4	8	2,75	2,5	40	25	500
4X45 TG T15	4	8	2,75	2,5	45	25	500
4X50 TG T15	4	8	2,75	2,5	50	30	500
4X55 TG T15	4	8	2,75	2,5	55	35	500
4X60 TG T15	4	8	2,75	2,5	60	35	200
4X65 TG T15	4	8	2,75	2,5	65	40	200
4X70 TG T15	4	8	2,75	2,5	70	40	200
4,5X30 TG T25	4,5	9	3,1	2,7	30	20	500
4,5X35 TG T25	4,5	9	3,1	2,7	35	20	500
4,5X40 TG T25	4,5	9	3,1	2,7	40	25	500
4,5X45 TG T25	4,5	9	3,1	2,7	45	25	500
4,5X50 TG T25	4,5	9	3,1	2,7	50	30	200
4,5X55 TG T25	4,5	9	3,1	2,7	55	30	200
4,5X60 TG T25	4,5	9	3,1	2,7	60	35	200
4,5X65 TG T25	4,5	9	3,1	2,7	65	35	200
4,5X70 TG T25	4,5	9	3,1	2,7	70	40	200

¹⁾ Gewindelänge

Nennmaß	D	DK	DS min.	K max.	L	L2 ²⁾	VPE
4,5X75 TG T25	4,5	9	3,1	2,7	75	40	200
4,5X80 TG T25	4,5	9	3,1	2,7	80	50	200
5X35 TG T25	5	9,7	3,45	3	35	20	200
5X40 TG T25	5	9,7	3,45	3	40	23	200
5X45 TG T25	5	9,7	3,45	3	45	28	200
5X50 TG T25	5	9,7	3,45	3	50	28	200
5X55 TG T25	5	9,7	3,45	3	55	38	200
5X60 TG T25	5	9,7	3,45	3	60	38	200
5X65 TG T25	5	9,7	3,45	3	65	38	200
5X70 TG T25	5	9,7	3,45	3	70	42	200
5X75 TG T25	5	9,7	3,45	3	75	42	200
5X80 TG T25	5	9,7	3,45	3	80	47	200
5X90 TG T25	5	9,7	3,45	3	90	55	200
5X100 TG T25	5	9,7	3,45	3	100	60	200
5X110 TG T25	5	9,7	3,45	3	110	60	100
5X120 TG T25	5	9,7	3,45	3	120	60	100
6X50 TG T25	6	11,8	4,2	3,6	50	30	200
6X55 TG T25	6	11,8	4,2	3,6	55	30	200
6X60 TG T25	6	11,8	4,2	3,6	60	35	200
6X65 TG T25	6	11,8	4,2	3,6	65	35	200
6X70 TG T25	6	11,8	4,2	3,6	70	40	200
6X75 TG T25	6	11,8	4,2	3,6	75	40	200
6X80 TG T25	6	11,8	4,2	3,6	80	45	100
6X90 TG T25	6	11,8	4,2	3,6	90	55	100
6X100 TG T25	6	11,8	4,2	3,6	100	60	100
6X110 TG T25	6	11,8	4,2	3,6	110	60	100
6X120 TG T25	6	11,8	4,2	3,6	120	60	100
6X130 TG T25	6	11,8	4,2	3,6	130	60	100
6X140 TG T25	6	11,8	4,2	3,6	140	60	100
6X150 TG T25	6	11,8	4,2	3,6	150	60	100
6X160 TG T25	6	11,8	4,2	3,6	160	60	100
6X180 TG T25	6	11,8	4,2	3,6	180	60	100

¹⁾ Gewindelänge





1



2



3

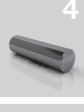

4



5



6



7



8



9

Nennmaß	D	DK	DS min.	K max.	L	L2 ²⁾	VPE
6X190 TG T25	6	11,8	4,2	3,6	190	60	100
6X200 TG T25	6	11,8	4,2	3,6	200	60	100
6X220 TG T25	6	11,8	4,2	3,6	220	60	100
6X240 TG T25	6	11,8	4,2	3,6	240	60	100
6X260 TG T25	6	11,8	4,2	3,6	260	60	100
6X280 TG T25	6	11,8	4,2	3,6	280	60	100
6X300 TG T25	6	11,8	4,2	3,6	300	60	100
8X80 TG T40	8	14,8	5,6	4,7	80	60	100
8X90 TG T40	8	14,8	5,6	4,7	90	60	100
8X100 TG T40	8	14,8	5,6	4,7	100	60	100
8X110 TG T40	8	14,8	5,6	4,7	110	70	100
8X120 TG T40	8	14,8	5,6	4,7	120	70	100
8X130 TG T40	8	14,8	5,6	4,7	130	70	100
8X140 TG T40	8	14,8	5,6	4,7	140	70	100
8X150 TG T40	8	14,8	5,6	4,7	150	70	100
8X160 TG T40	8	14,8	5,6	4,7	160	70	100
8X180 TG T40	8	14,8	5,6	4,7	180	100	100
8X190 TG T40	8	14,8	5,6	4,7	190	100	100
8X200 TG T40	8	14,8	5,6	4,7	200	100	100
8X220 TG T40	8	14,8	5,6	4,7	220	100	100
8X240 TG T40	8	14,8	5,6	4,7	240	100	100
8X260 TG T40	8	14,8	5,6	4,7	260	100	100
8X280 TG T40	8	14,8	5,6	4,7	280	100	100
8X300 TG T40	8	14,8	5,6	4,7	300	100	100
8X320 TG T40	8	14,8	5,6	4,7	320	100	50
8X340 TG T40	8	14,8	5,6	4,7	340	100	50
8X360 TG T40	8	14,8	5,6	4,7	360	100	50
8X380 TG T40	8	14,8	5,6	4,7	380	100	50
8X400 TG T40	8	14,8	5,6	4,7	400	100	50
10X80 TG T40	10	18,5	6,9	6	80	60	50
10X90 TG T40	10	18,5	6,9	6	90	60	50
10X100 TG T40	10	18,5	6,9	6	100	80	50

¹⁾ Gewindelänge

Nennmaß	D	DK	DS min.	K max.	L	L2 ²⁾	VPE
10X110 TG T40	10	18,5	6,9	6	110	80	50
10X120 TG T40	10	18,5	6,9	6	120	80	50
10X130 TG T40	10	18,5	6,9	6	130	80	50
10X140 TG T40	10	18,5	6,9	6	140	80	50
10X150 TG T40	10	18,5	6,9	6	150	80	50
10X160 TG T40	10	18,5	6,9	6	160	100	50
10X180 TG T40	10	18,5	6,9	6	180	100	50
10X190 TG T40	10	18,5	6,9	6	190	100	50
10X200 TG T40	10	18,5	6,9	6	200	100	50
10X220 TG T40	10	18,5	6,9	6	220	100	50
10X240 TG T40	10	18,5	6,9	6	240	100	50
10X260 TG T40	10	18,5	6,9	6	260	100	50
10X280 TG T40	10	18,5	6,9	6	280	100	50
10X300 TG T40	10	18,5	6,9	6	300	100	50
10X320 TG T40	10	18,5	6,9	6	320	100	50
10X340 TG T40	10	18,5	6,9	6	340	100	50
10X360 TG T40	10	18,5	6,9	6	360	100	50
10X380 TG T40	10	18,5	6,9	6	380	100	50
10X400 TG T40	10	18,5	6,9	6	400	100	50

Revolutionäre Spitzen- und Schaftgeometrie - Ansetzen, schrauben und fertig - Kein Vorbohren notwendig - Schnelleres Einschrauben - Deutliche Reduzierung der Spaltwirkung - Geringes Einschraubdrehmoment - Hohe Wirtschaftlichkeit - mit bauaufsichtlicher Zulassung

¹⁾ Gewindelänge





Maße in mm

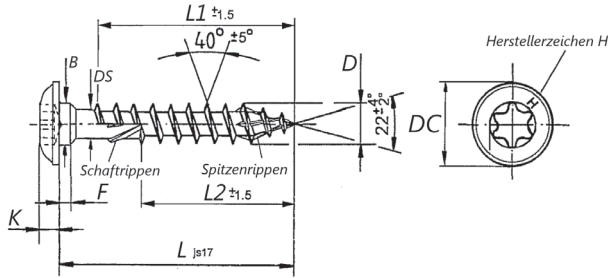

Nennmaß	D	B	DS	DK	K	F	L	L1	VPE
6X40 VG T25	6	6	4,4	12	2,9	1,8	40	33	100
6X50 VG T25	6	6	4,4	12	2,9	1,8	50	43	100
6X60 VG T25	6	6	4,4	12	2,9	1,8	60	53	100
6X70 VG T25	6	6	4,4	12	2,9	1,8	70	60	100
8X50 VG T40	8	8	5,6	16	4	2,6	50	40	100
8X60 VG T40	8	8	5,6	16	4	2,6	60	50	100
8X70 VG T40	8	8	5,6	16	4	2,6	70	60	100
8X80 VG T40	8	8	5,6	16	4	2,6	80	70	100
8X90 VG T40	8	8	5,6	16	4	2,6	90	80	100
8X100 VG T40	8	8	5,6	16	4	2,6	100	80	100
8X120 VG T40	8	8	5,6	16	4	2,6	120	100	100

Höhere Lastübertragung durch vergrößerte Klemmfläche des Kopfes - Zugelassen als Holzverbindungsmitel - zugelassen zur Befestigung von Aufdach-Dämmsystemen - der aufgedickte Schaft unter dem Kopf ermöglicht die Kombination mit Unterlegscheiben - Patentierte HECO-TOPIX®-Spitze für spreisfreies Einschrauben - Schaftfräser für reduziertes Einschraubdrehmoment und spannungsfreie Verbindung - Schnell und einfach in der Anwendung - Die bauaufsichtliche Zulassung garantiert eine ständig überwachte Qualität - Mit bewährtem T-Drive

Maße in mm

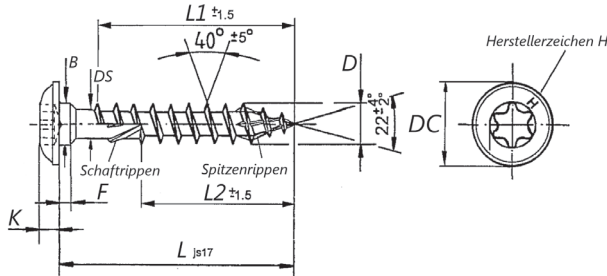

Nennmaß	D	B	DS	DK	K	F	L	L2	VPE
6X80 TG T25	6	6	4,4	12	2,9	1,8	80	60	100
6X90 TG T25	6	6	4,4	12	2,9	1,8	90	70	100
6X100 TG T25	6	6	4,4	12	2,9	1,8	100	70	100
6X120 TG T25	6	6	4,4	12	2,9	1,8	120	70	100
6X140 TG T25	6	6	4,4	12	2,9	1,8	140	70	100
6X160 TG T25	6	6	4,4	12	2,9	1,8	160	70	100
6X180 TG T25	6	6	4,4	12	2,9	1,8	180	70	100
6X200 TG T25	6	6	4,4	12	2,9	1,8	200	70	100
6X220 TG T25	6	6	4,4	12	2,9	1,8	220	70	100
6X240 TG T25	6	6	4,4	12	2,9	1,8	240	70	100
6X260 TG T25	6	6	4,4	12	2,9	1,8	260	70	100
6X280 TG T25	6	6	4,4	12	2,9	1,8	280	70	100
6X300 TG T25	6	6	4,4	12	2,9	1,8	300	70	100
6X320 TG T25	6	6	4,4	12	2,9	1,8	320	70	100
6X340 TG T25	6	6	4,4	12	2,9	1,8	340	70	100
6X360 TG T25	6	6	4,4	12	2,9	1,8	360	70	100
6X380 TG T25	6	6	4,4	12	2,9	1,8	380	70	100
6X400 TG T25	6	6	4,4	12	2,9	1,8	400	70	100
8X80 TG T40	8	8	5,6	14,8	4	2,6	80	60	100
8X90 TG T40	8	8	5,6	16	4	2,6	90	60	100
8X100 TG T40	8	8	5,6	14,8	4	2,6	100	60	100
8X120 TG T40	8	8	5,6	14,8	4	2,6	120	70	100
8X140 TG T40	8	8	5,6	14,8	4	2,6	140	70	100
8X160 TG T40	8	8	5,6	14,8	4	2,6	160	100	100



Nennmaß	D	B	DS	DK	K	F	L	L2	VPE
8X180 TG T40	8	8	5,6	14,8	4	2,6	180	100	100
8X200 TG T40	8	8	5,6	14,8	4	2,6	200	100	100
8X220 TG T40	8	8	5,6	14,8	4	2,6	220	100	100
8X240 TG T40	8	8	5,6	14,8	4	2,6	240	100	100
8X260 TG T40	8	8	5,6	14,8	4	2,6	260	100	100
8X280 TG T40	8	8	5,6	14,8	4	2,6	280	100	100
8X300 TG T40	8	8	5,6	14,8	4	2,6	300	100	50
8X320 TG T40	8	8	5,6	14,8	4	2,6	320	100	50
8X340 TG T40	8	8	5,6	14,8	4	2,6	340	100	50
8X360 TG T40	8	8	5,6	16	4	2,6	360	100	50
8X380 TG T40	8	8	5,6	14,8	4	2,6	380	100	50
8X400 TG T40	8	8	5,6	16	4	2,6	400	100	50
10X80 TG T40	10	10	6,9	20	4,2	2,6	80	60	50
10X90 TG T40	10	10	6,9	20	4,2	2,6	90	60	50
10X100 TG T40	10	10	6,9	20	4,2	2,6	100	60	50
10X120 TG T40	10	10	6,9	18,5	4,2	2,6	120	80	50
10X140 TG T40	10	10	6,9	20	4,2	2,6	140	80	50
10X160 TG T40	10	10	6,9	20	4,2	2,6	160	100	50
10X180 TG T40	10	10	6,9	20	4,2	2,6	180	100	50
10X200 TG T40	10	10	6,9	18,5	4,2	2,6	200	100	50
10X220 TG T40	10	10	6,9	18,5	4,2	2,6	220	100	50
10X240 TG T40	10	10	6,9	18,5	4,2	2,6	240	100	50
10X260 TG T40	10	10	6,9	18,5	4,2	2,6	260	100	50
10X280 TG T40	10	10	6,9	18,5	4,2	2,6	280	100	50
10X300 TG T40	10	10	6,9	18,5	4,2	2,6	300	100	50
10X320 TG T40	10	10	6,9	18,5	4,2	2,6	320	100	50
10X340 TG T40	10	10	6,9	18,5	4,2	2,6	340	100	50
10X360 TG T40	10	10	6,9	18,5	4,2	2,6	360	100	50
10X380 TG T40	10	10	6,9	18,5	4,2	2,6	380	100	50
10X400 TG T40	10	10	6,9	18,5	4,2	2,6	400	100	50

Höhere Lastübertragung durch vergrößerte Klemmfläche des Kopfes - Zugelassen als Holzverbindungsmittel - zugelassen zur Befestigung von Aufdach-Dämmsystemen - der aufgedickte Schaft unter dem Kopf ermöglicht die Kombination mit Unterlegscheiben - Patentierte HECO-TOPIX®-Spitze für spreizfreies Einschrauben - Schaftfräser für reduziertes Einschraubdrehmoment und spannungsfreie Verbindung - Schnell und einfach in der Anwendung - Die bauaufsichtliche Zulassung garantiert eine ständig überwachte Qualität - Mit bewährtem T-Drive

1



2



3



4



5



6



7



8



9





1



2



3



4



5



6



7



8





Maße in mm

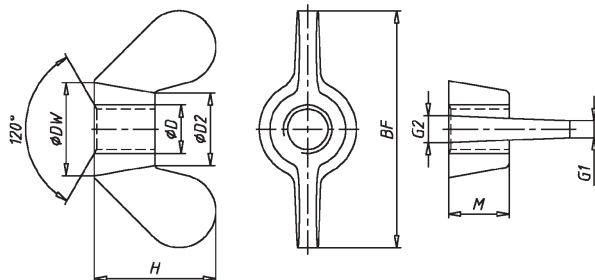

D	M4	M5	M6	M8	M10	M12	M16	M20	M24
P ¹⁾	0,7	0,8	1	1,25	1,5	1,75	2	2,5	3
DW max	8	11	13	16	20	23	29	35	44
BF max	20	26	33	39	51	65	73	90	110
G1 max	1,9	2,3	2,3	2,8	4,4	4,9	6,4	6,9	9,4
G2 max	2,3	2,8	3,3	4,4	5,4	6,4	7,5	8	10,5
M max	4,6	6,5	8	10	12	14	17	21	25
D2 max	7	9	11	12,5	16,5	19,5	23	29	37,5
H max	10,5	13	17	20	25	33,5	37,5	46,5	56,5
VPE	200	200	200	100	100	50	20	20	20

Lieferbar in Temperguss, Polyamid, Messing sowie Edelstahl A2 und Edelstahl A4
 Flügelmuttern sind nur für die Montage von Hand vorgesehen.

¹⁾ Gewindesteigung

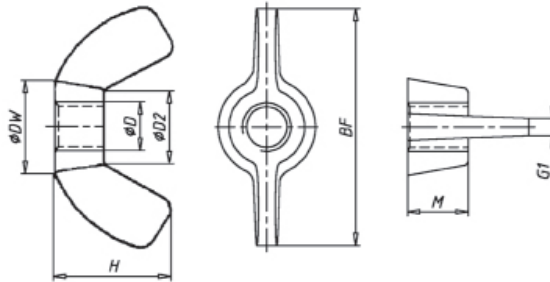

Maße in mm

D	M4	M5	M6	M8	M10	M12
P ¹⁾	0,7	0,8	1	1,25	1,5	1,75
DW max	9	12	14	16	21	24
BF max	21	26,5	32	38	50	66
M max	4,6	6	7	8,5	10	13
H max	11	13	16	19	24	32
VPE	200	200	200	100	100	50

Lieferbar in Stahl, Temperguss, Polyamid sowie Edelstahl A2 und Edelstahl A4
Flügelmuttern sind nur für die Montage von Hand vorgesehen.

¹⁾ Gewindesteigung





Maße in mm

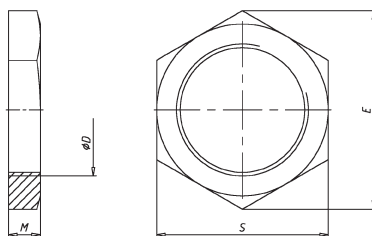

D	E	M	S	VPE
G 1/8"	19,85	6	18	100
G 1/4"	22,91 / 23,91	6	21 / 22 ¹⁾	100
G 3/8"	29,56	7	27	100
G 1/2"	35,03 / 37,29	8	32 / 34 ¹⁾	100
G 3/4"	39,55	9	36	50
G 1"	50,85	10	46	50
G 1 1/4"	60,79	11	55	50
G 1 1/2"	66,44	12	60	50
G 2"	82,60	13	75	25

¹⁾Neue Schlüsselweite

Lieferbar in Stahl, Messing sowie Edelstahl A2
 Form A: ohne Gewindeansenkung (Siehe Abb.)
 Form B: mit einseitiger Gewindeansenkung

Maße in mm

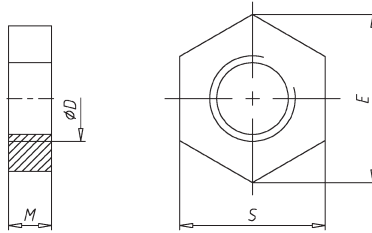

D	M2	M2,5	M3	M4	M5	M6
P ¹⁾	0,4	0,45	0,5	0,7	0,8	1
E	4,32	5,45	6,01	7,66	8,79	11,05
M	1,2	1,6	1,8	2,2	2,7	3,2
S	4	5	5,5	7	8	10
VPE	1000	1000	1000	1000	1000	1000

D	M8	M10	M12	M14	M16	M20	M24
P ¹⁾	1,25	1,5	1,75	2	2	2,5	3
E	14,38	18,9	21,1	24,49	26,75	32,95	39,55
M	4	5	6	7	8	10	12
S	13	17	19	22	24	30	36
VPE	1000	500	500	250	200	100	100

Lieferbar in Güte: 04, Messing sowie Edelstahl A2 und Edelstahl A4
Auch mit Feingewinde lieferbar.

¹⁾ Gewindesteigung





Maße in mm

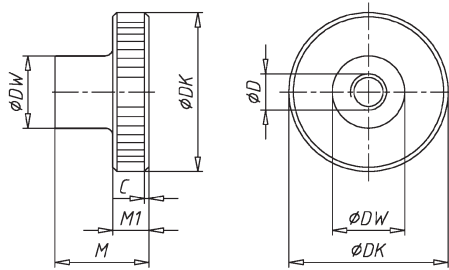

D	M3	M4	M5	M6	M8	M10	M12 ²⁾
P ¹⁾	0,5	0,7	0,8	1	1,25	1,5	1,75
DK	12	16	20	24	30	36	42
DW	6	8	10	12	16	20	24
C	0,3	0,4	0,4	0,5	0,6	0,8	1
M	7,5	9,5	11,5	15	18	23	28
M1	2,5	3,5	4	5	6	8	10
VPE	100	100	100	50	50	50	50

Lieferbar in Güte .5, Messing sowie Edelstahl A1

¹⁾ Gewindesteigung

²⁾ nicht in DIN enthalten.

Maße in mm

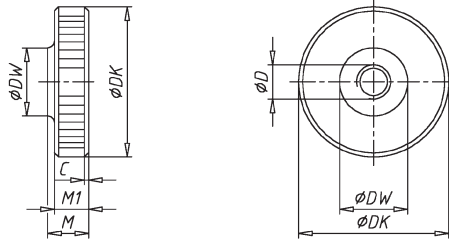

D	M3	M4	M5	M6	M8	M10
P ¹⁾	0,5	0,7	0,8	1	1,25	1,5
DK	12	16	20	24	30	36
DW	6	8	10	12	16	20
C	0,3	0,4	0,4	0,5	0,6	0,8
M	3	4	5	6	8	10
M1	2,5	3,5	4	5	6	8
VPE	100	100	100	50	50	50

Lieferbar in Güte .5, Messing sowie Edelstahl A1

¹⁾ Gewindesteigung





Maße in mm

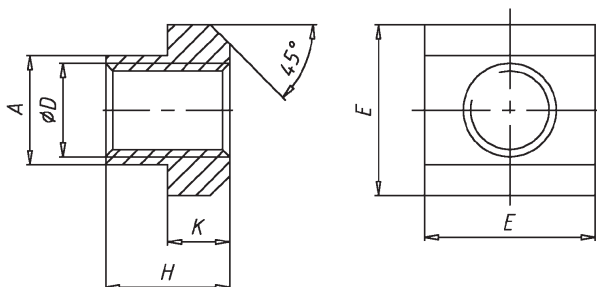

Nennmaß	A	D	P ¹⁾	E	H	K	VPE
M4x5	4,6	M4	0,7	9	6,5	3	10
M5x6	5,6	M5	0,8	10	8	4	10
M6x8	7,6	M6	1	13	10	6	10
M6x10	9,6	M6	1	15	12	6	10
M8x10	9,6	M8	1,25	15	12	6	10
M8x12	11,6	M8	1,25	18	14	7	10
M10x12	11,6	M10	1,5	18	14	7	10
M10x14	13,6	M10	1,5	22	16	8	10
M12x14	13,6	M12	1,75	22	16	8	10
M12x16	15,6	M12	1,75	25	18	9	5
M14x16	15,6	M14	2	25	18	9	5
M14x18	17,6	M14	2	28	20	10	5
M16x18	17,6	M16	2	28	20	10	5
M16x20	19,6	M16	2	32	24	12	5
M18x20	19,6	M18	2,5	32	24	12	5
M20x22	21,6	M20	2,5	35	28	14	5
M22x24	23,6	M22	2,5	40	32	16	5
M24x28	27,6	M24	3	44	36	18	5
M27x32	31,5	M27	3	50	40	20	5
M30x36	35,5	M30	3,5	54	44	22	1

Lieferbar in Güte: .8, Güte: .10 sowie NIRO
Nutenführung gefräst.

¹⁾ Gewindesteigung

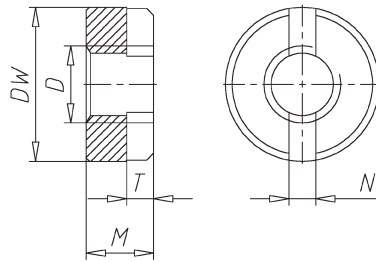

Maße in mm

D	M3	M4	M5	M6	M8	M10	M12
P ¹⁾	0,5	0,7	0,8	1	1,25	1,5	1,75
DW	6	8	9	11	14	18	21
M	2,5	3,5	4,2	5	6,5	8	10
N	1,2	1,4	2	2,5	3	3,5	4
T min	1	1,2	1,5	2,0	2,5	3,2	3,8
VPE	500	500	500	200	200	100	100

Lieferbar in Stahl, Messing sowie Edelstahl A1

¹⁾ Gewindesteigung





Maße in mm

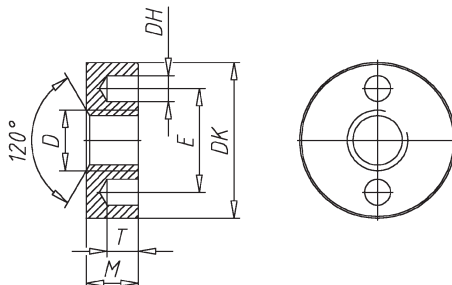

D	M3	M4	M5	M6	M8	M10
P ¹⁾	0,5	0,7	0,8	1	1,25	1,5
DH	1,5	1,5	2	2,5	3	3,5
DK	8	10	12	14	18	22
E	5,5	7	8	10	13	15
M	2,5	3,5	4,2	5	6,5	8
T min	1,3	1,8	2,3	2,8	3,3	3,8
VPE	100	100	100	100	100	100

Lieferbar in Stahl, Messing sowie Edelstahl A1

¹⁾ Gewindesteigung

Maße in mm

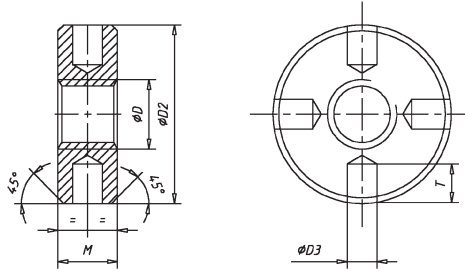

D	M3	M4	M5	M6	M8	M10
P ¹⁾	0,5	0,7	0,8	1	1,25	1,5
D2	8	10	12	14	18	22
D3	1,5	1,5	2	2,5	3	3,5
M	2,5	3,5	4,2	5	6,5	8
T min	1,3	1,8	2,3	2,8	3,3	3,8
VPE	100	100	100	100	100	100

Lieferbar inStahl, Messing sowie Edelstahl A1

¹⁾ Gewindesteigung



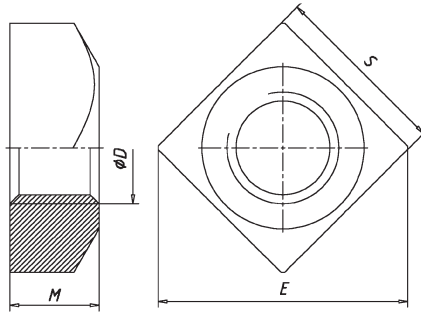

Maße in mm

D	M4 ²⁾	M5	M6	M8	M10	M12	M16
P ¹⁾	0,7	0,8	1	1,25	1,5	1,75	2
E	10,3	11,3	14,1	18,4	22,6 / 24	25,4 / 26,9	33,9
M	3	4	5	6,5	8	10	13
S	7	8	10	13	16 / 17	18 / 19	24
VPE	1000	1000	1000	500	500	200	100

Lieferbar in Güte: .5 sowie Edelstahl A2

¹⁾ Gewindesteigung

²⁾ nicht in DIN enthalten.

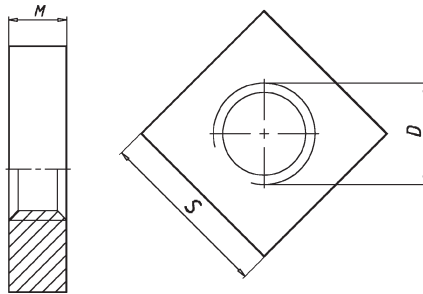

Maße in mm

D	M2	M2,5	M3	M3,5	M4	M5	M6	M8	M10
P ¹⁾	0,4	0,45	0,5	0,6	0,7	0,8	1	1,25	1,5
M	1,2	1,6	1,8	2	2,2	2,7	3,2	4	5
S	4	5	5,5	6	7	8	10	13	16
VPE	1000	1000	1000	1000	1000	1000	1000	500	200

Lieferbar in Güte: 04, Messing sowie Edelstahl A2

¹⁾ Gewindesteigung



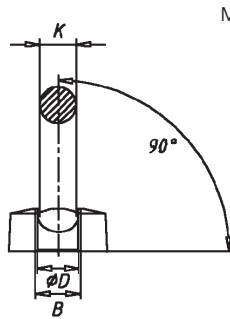
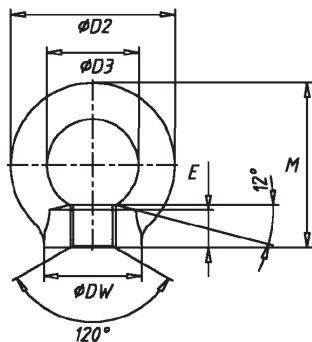

Maße in mm

D	M8	M10	M12	M16	M20	M24	M30	M36	M42
P ¹⁾	1,25	1,5	1,75	2	2,5	3	3,5	4	4,5
B	10	12	14	16	19	24	28	32	38
D2	36	45	54	63	72	90	108	126	144
D3	20	25	30	35	40	50	65	75	85
E	8,5	10	11	13	16	20	25	30	35
M	36	45	53	62	71	90	109	128	147
K	8	10	12	14	16	20	24	28	32
DW	20	25	30	35	40	50	60	70	80
VPE	50	50	25	25	10	10	10	5	5

Lieferbar in Güte: C15, C15E sowie Edelstahl A2 und Edelstahl A4
 Die DIN 582 Ausgabe 1971-04 in Werkstoff C15 wurde durch die DIN 582 Ausgabe 2003-08 in Werkstoff C15E abgelöst. Aufgrund der großen Nachfrage führen wir weiterhin Ringmuttern nach der alten DIN 582 (1972-03) in Werkstoff: C15. Diese dürfen aber nicht für sicherheitsrelevante Anwendungen verwendet werden. Dies gilt insbesondere im Bereich der Lastaufnahme.

¹⁾ Gewindesteigung

Traglastentabelle

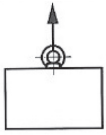
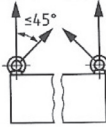
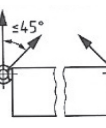
	Gewinde (D)	M8	M10	M12	M16	M20	M24	M30	M36	M42
 Tragfähigkeit axial je Ringmutter kg		140	230	340	700	1200	1800	3200	4600	6300
 Tragfähigkeit je Ringmutter $\leq 45^\circ$ kg		100	170	240	500	860	1290	2300	3300	4500
 Tragfähigkeit seitlich je Ringmutter $\leq 45^\circ$ kg		70	115	170	350	600	900	1600	2300	3150

Ringmütern nach dieser Norm dienen vornehmlich als Lastaufnahmemittel zur dauerhaften Befestigung an Bauteilen zu deren Transport. Für die wechselnde Benutzung an verschiedenen zu transportierenden Gegenständen, wie z.B. Großwerkzeugen, müssen Ringmütern mit dem nächstgrößeren Gewindedurchmesser verwendet werden. Bei Anwendung mit mehrsträngigen Anschlagmitteln sind die Regeln z.B. nach DIN 818-4 zu beachten.

Die Tragfähigkeitsangaben aus der Tabelle gelten nur, wenn:

- die Ringmutter vollständig aufgeschraubt ist.
- die Ringmutter eben und vollflächig auf der Auflagefläche aufliegt.
- die Länge des Gegengewindes ausreicht.
- die Festigkeit des Elements mit dem Gegengewinde (Schraube) ausreicht.

Benutzerinformation:

1. Die in der zweiten Zeile der Tabelle angegebene Tragfähigkeit gilt bis max. 45° Neigungswinkel, die in der dritten Zeile angegebene Tragfähigkeit bei seitlich eingeschraubten Ringmütern bis max. 45° Neigungswinkel in alle Richtungen bezüglich der Ringebene. Seitenzug sollte nicht angewendet werden.

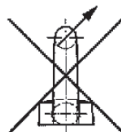
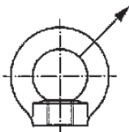

2. Bei Verwendung von Schrauben sollte unter dem Schraubenkopf eine Scheibe vorgesehen werden.
3. Ringmütern sollten vor dem Gebrauch auf festen Sitz und auffällige Beschädigung überprüft werden.
4. Ringmütern mit Verformungen sollten nicht weiterbenutzt und nicht wieder eingeschraubt werden.
5. Die nachträgliche farbliche Kennzeichnung der Ringmütern ist zu vermeiden, um Verwechslungen mit hochfesten Anschlagpunkten zu vermeiden.



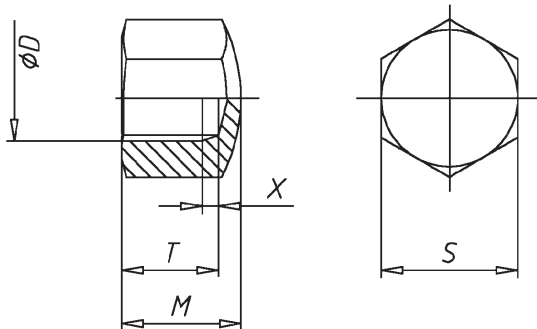

Maße in mm

D	M4	M5	M6	M8	M10	M12	M16	M20	M24
P ¹⁾	0,7	0,8	1	1,25	1,5	1,75	2	2,5	3
M	5,5	7	9	12	14	16	20	25	30
T min	4,16	4,96	6,71	9,21	10,65	13,15	16,65	20,58	23,58
S	7	8	10	13	16	18	24	30	36
X ²⁾	1,05	1,2	1,5	1,87	2,25	6,4	7,3	9,3	10,7
VPE	1000	1000	500	500	250	200	100	50	25

Lieferbar in Güte: .6, Messing sowie Edelstahl A2 und A4

¹⁾ Gewindesteigung

²⁾ bis 10 mm Gewinde- Nenndurchmesser mit Gewindefreistich oder Gewindeauslauf nach Wahl des Herstellers.
ab 12 mm Gewinde- Nenndurchmesser mit Gewindefreistich.

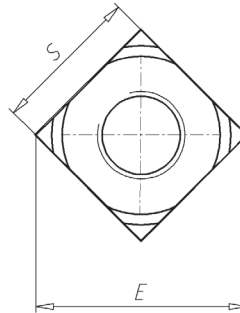
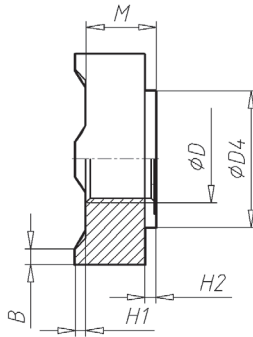

Maße in mm

D	M4	M5	M6	M8	M10	M12
P ¹⁾	0,7	0,8	1	1,25	1,5	1,75
H1	0,6	0,8	0,8	1	1,2	1,4
H2 min	0,4	0,6	0,7	1,1	1,25	1,75
E	9	12	13	18	22	25
B	0,8	1	1,2	1,5	1,8	2
M	3,5	4,2	5	6,5	8	9,5
S	7	9	10	14	17	19
D4	6,4	8,2	9,1	12,8	15,6	17,4
VPE	1000	1000	1000	1000	500	250

Lieferbar in Stahl sowie Edelstahl A2
Kohlenstoffgehalt max 0,25 %

¹⁾ Gewindesteigung



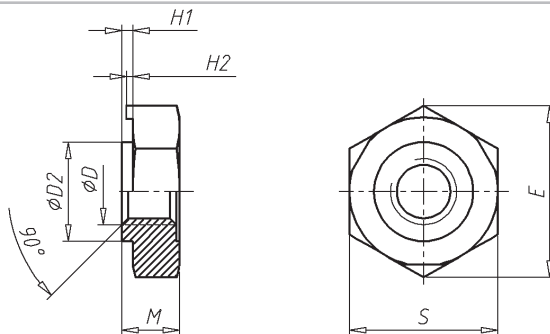

Maße in mm

D	M3	M4	M5	M6	M8	M10	M12	M14	M16
P ¹⁾	0,5	0,7	0,8	1	1,25	1,5	1,75	2	2
D2	4,5	6	7	8	10,5	12,5	14,8	16,8	18,8
H1	0,55	0,65	0,7	0,75	0,9	1,15	1,4	1,8	1,8
H2	0,25	0,35	0,4	0,4	0,5	0,65	0,8	1	1
M	3	3,5	4	5	6,5	8	10	11	13
S	7,5	9	10	11	14	17	19	22	24
E	8,15	9,83	10,95	12,02	15,38	18,74	20,91	24,27	26,51
VPE	1000	1000	1000	1000	1000	500	250	200	200

Lieferbar in Stahl sowie Edelstahl A2

Kohlenstoffgehalt max 0,25 %

¹⁾ Gewindesteigung

Maße in mm

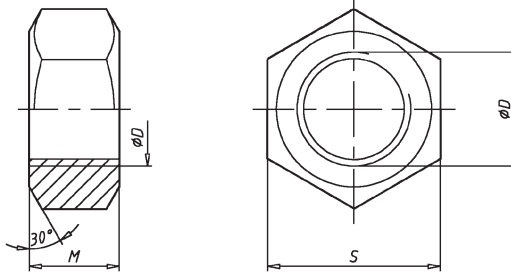

D	M3	M4	M5	M6	M7	M8	M10	M12	M14	M16
P ¹⁾	0,5	0,7	0,8	1	1	1,25	1,5	1,75	2	2
M max	2,4	3,2	4	5	5,5	6,5	8	10	11	13
S	5,5	7	8	10	11	13	17	19	22	24
VPE	1000	1000	1000	1000	1000	1000	500	500	200	200
D	M18	M20	M22	M24	M27	M30	M33	M36	M39	M42
P ¹⁾	2,5	2,5	2,5	3	3	3,5	3,5	4	4	4,5
M max	15	16	18	19	22	24	26	29	31	34
S	27	30	32	36	41	46	50	55	60	65
VPE	100	100	50	50	25	25	25	15	10	5

Lieferbar in Güte: .5-2, .8, .10, .12, Messing, Aluminium, Polyamid sowie Edelstahl A2 und Edelstahl A4
Auch mit Feingewinde lieferbar.

¹⁾ Gewindesteigung



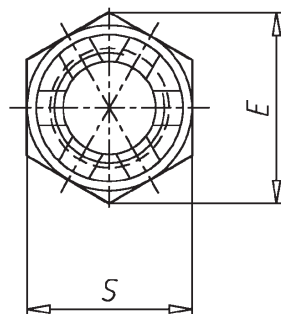
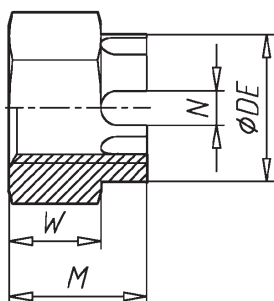

Maße in mm

D	M6	M8	M10	M12	M14
P ¹⁾	1	1,25	1,5	1,75	2
DE	-	-	-	16/17	18/19
M	7,5	9,5	12	15	16
N max	2,25	2,75	3,05	3,8	3,8
S	10	13	16/17	18/19	21/22
W max	5	6,5	8	10	11
E	11,05	14,38	17,77/18,9	20,03/21,1	23,35/24,49
SPLINT	1,6 x 14	2 x 16	2,5 x 20	3,2 x 22	3,2 x 25
VPE	200	200	100	100	50
D	M16	M20	M24	M30	M36
P ¹⁾	2	2,5	3	3,5	4
DE	22	28	34	42	50
M	19	22	27	33	38
N max	4,8	4,8	5,8	7,36	7,36
S	24	30	36	46	55
W max	13	16	19	24	29
E	26,75	32,95	39,55	50,85	60,79
SPLINT	4 x 28	4 x 36	5 x 40	6,3 x 50	6,3 x 63
VPE	50	50	25	20	10

Lieferbar in Güte: .8 sowie Edelstahl A2

Auch mit Feingewinde lieferbar.

¹⁾ Gewindesteigung

Maße in mm

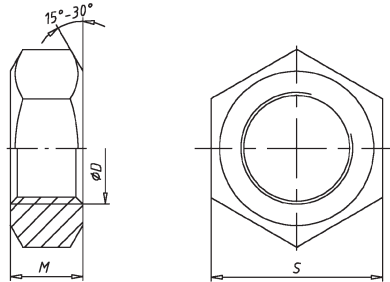

D	M8	M10	M12	M14	M16	M18	M20	M24	M27	M30	M33	M36
P ¹⁾	1,25	1,5	1,75	2	2	2,5	2,5	3	3	3,5	3,5	4
M	5	6	7	8	8	9	9	10	12	12	14	14
S	13	17	19	22	24	27	30	36	41	46	50	55
VPE	500	500	500	200	200	100	50	50	50	25	25	25

Lieferbar in Güte: 04, 05, 17H, 22H sowie Edelstahl A2
Auch mit Feingewinde lieferbar.

¹⁾ Gewindesteigung





Maße in mm

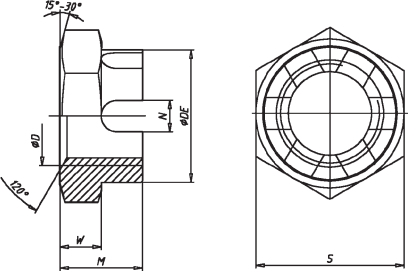

D	M6	M8	M10	M12	M16	M20	M24	M27	M30
P ¹⁾	1	1,25	1,5	1,75	2	2,5	3	3	3,5
DE max	-	-	-	17	22	28	34	38	42
M	6	8	9	10	12	13	15	17	18
N max	2,25	2,75	3,05	3,8	4,8	4,8	5,8	5,8	7,36
S	10	13	17	19	24	30	36	41	46
W max	3,5	4,5	5	6	7	8	9	11	11
SPLINT	1,6 x 14	2 x 16	2,5 x 20	3,2 x 22	4 x 28	4 x 36	5 x 40	5 x 45	6,3 x 50
VPE	100	100	100	100	50	50	25	25	20

Lieferbar in Güte: 17H
Auch mit Feingewinde lieferbar.

¹⁾ Gewindesteigung

Maße in mm

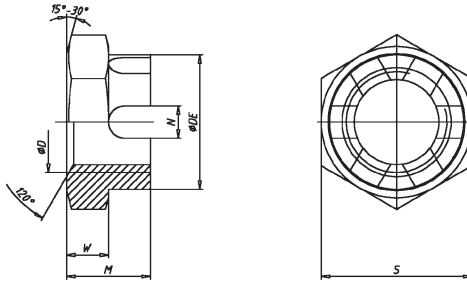

D	M6	M8	M10	M12	M16	M20	M24
P ¹⁾	1	1,25	1,5	1,75	2	2,5	3
DE max	-	-	-	16/17	22	28	34
M	5	6,5	8	10	13	16	19
N max	2,25	2,75	3,05	3,8	4,8	4,8	5,8
S	10	13	16/17	18/19	24	30	36
W max	2,5	3,5	4	5	7	10	11
SPLINT	1,6 x 14	2 x 16	2,5 x 20	3,2 x 22	4 x 28	4 x 36	5 x 40
VPE	100	100	100	100	100	50	25

Lieferbar in Güte: 04
Auch mit Feingewinde lieferbar.

¹⁾ Gewindesteigung



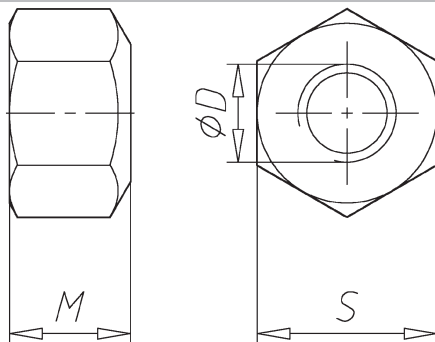

Maße in mm

D	M3	M4	M5	M6	M8	M10	M12
P ¹⁾	0,5	0,7	0,8	1	1,25	1,5	1,75
M max	3,7	4,2	5,1	6	8	10	12
S	5,5	7	8	10	13	17	19
VPE	1000	1000	1000	1000	1000	500	250

D	M14	M16	M18	M20	M22	M24	M27	M30
P ¹⁾	2	2	2,5	2,5	2,5	3	3	3,5
M max	14	16	18	20	22	24	27	30
S	22	24	27	30	32	36	41	46
VPE	200	100	100	100	50	50	50	25

Lieferbar in Güte: .8, .10 sowie Edelstahl A2 und A4
Gestaltung des Klemmteils nach Wahl des Herstellers.

Auch mit Feingewinde lieferbar.

¹⁾ Gewindesteigung

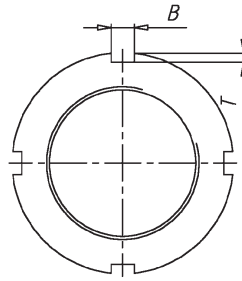
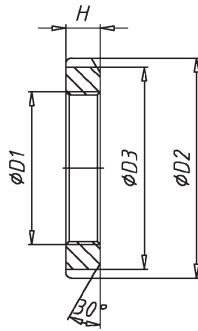

Maße in mm

Nennmaß	D1	D2	D3	H	B	T	VPE
KM 0	M10x0,75	18	13,5	4	3	2	10
KM 1	M12x1	22	17	4	3	2	10
KM 2	M15x1	25	21	5	4	2	10
KM 3	M17x1	28	24	5	4	2	10
KM 4	M20x1	32	26	6	4	2	10
KM 5	M25x1,5	38	32	7	5	2	10
KM 6	M30x1,5	45	38	7	5	2	10
KM 7	M35x1,5	52	44	8	5	2	10
KM 8	M40x1,5	58	50	9	6	2,5	5
KM 9	M45x1,5	65	56	10	6	2,5	5
KM 10	M50x1,5	70	61	11	6	2,5	5
KM 11	M55x2	75	67	11	7	3	5
KM 12	M60x2	80	73	11	7	3	5
KM 13	M65x2	85	79	12	7	3	5
KM 14	M70x2	92	85	12	8	3,5	5
KM 15	M75x2	98	90	13	8	3,5	5
KM 16	M80x2	105	95	15	8	3,5	5
KM 17	M85x2	110	102	16	8	3,5	5
KM 18	M90x2	120	108	16	10	4	5
KM 19	M95x2	125	113	17	10	4	5
KM 20	M100x2	130	120	18	10	4	1
KM 21	M105x2	140	126	18	12	5	1
KM 22	M110x2	145	133	19	12	5	1





1



2



3



4



5



6



7



8



9

Nennmaß	D1	D2	D3	H	B	T	VPE
KM 23	M115x2	150	137	19	12	5	1
KM 24	M120x2	155	138	20	12	5	1
KM 25	M125x2	160	148	21	12	5	1
KM 26	M130x2	165	149	21	12	5	1
KM 27	M135x2	175	160	22	14	6	1
KM 28	M140x2	180	160	22	14	6	1
KM 29	M145x2	190	171	24	14	6	1
KM 30	M150x2	195	171	24	14	6	1

Lieferbar in Stahl sowie Edelstahl A2

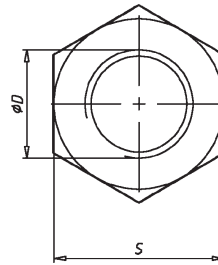
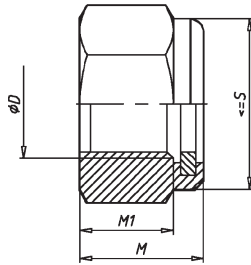

Maße in mm

D	M5	M6	M8	M10	M12	M14	M16	M18	M20	M22	M24
P ¹⁾	0,8	1	1,25	1,5	1,75	2	2	2,5	2,5	2,5	3
M	6,3	8	9,5	11,5	14	16	18	20	22	25	28
M1	4,4	4,9	6,44	8,04	10,37	12,1	14,1	15,1	16,9	18,1	20,2
S	8	10	13	17	19	22	24	27	30	32	36
VPE	1000	1000	1000	500	250	250	100	100	100	50	50

Lieferbar in Güte: .8, .10 sowie Edelstahl A2

Geeignet für Anwendungstemperaturen von -50° bis +120°C

Gestaltung des Klemnteils nach Wahl des Herstellers.

¹⁾ Gewindesteigung





Maße in mm

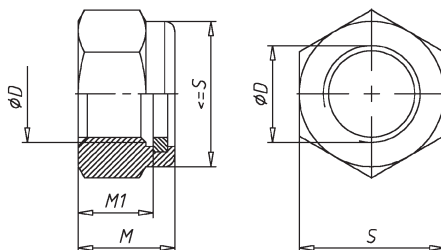

D	M3	M4	M5	M6	M7	M8	M10	M12	M14
P ¹⁾	0,5	0,7	0,8	1	1	1,25	1,5	1,75	2
M	4	5	5	6	7,5	8	10	12	14
M1	2,4	2,9	3,2	4	4,7	5,5	6,5	8	9,5
S	5,5	7	8	10	11	13	17	19	22
VPE	1000	1000	1000	1000	1000	1000	500	250	200

D	M16	M18	M20	M22	M24	M27	M30	M33	M36
P ¹⁾	2	2,5	2,5	2,5	3	3	3,5	3,5	4
M	16	18,5	20	22	24	27	30	33	36
M1	10,5	13	14	15	15	17	19	22	25
S	24	27	30	32	36	41	46	50	55
VPE	200	200	100	50	50	50	25	25	20

Lieferbar in Güte: .8, .10 sowie Edelstahl A2 und A4
 Geeignet für Anwendungstemperaturen von -50° bis +120°C
 Klemmteilgestaltung nach Wahl des Herstellers.

¹⁾ Gewindesteigung

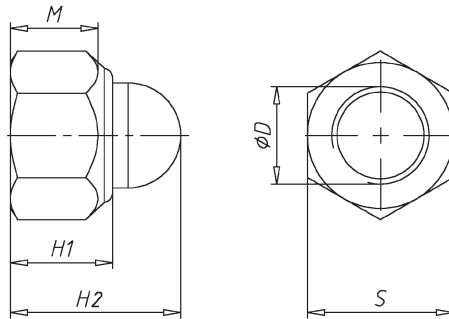

Maße in mm

D	M4	M5	M6	M8	M10	M12	M16
P ¹⁾	0,7	0,8	1	1,25	1,5	1,75	2
H1	5,6	6	7,5	8,9	10,5	13,5	16,5
H2	9,6	10,5	12	14	18,1	22,5	27,5
M min ²⁾	2,9	4,4	4,9	6,44	8,04	10,37	14,1
S max	7	8	10	13	17	19	24
VPE	1000	1000	1000	500	500	100	100

Lieferbar in Güte .8 sowie Edelstahl A2
 Geeignet für Anwendungstemperaturen von -50° bis +120°C
 Klemmteilgestaltung nach Wahl des Herstellers.

¹⁾ Gewindesteigung

²⁾ Antriebshöhe gleichzeitig Mindest-Gewindehöhe





1



2



3



4



5



6



7



8



9

Maße in mm

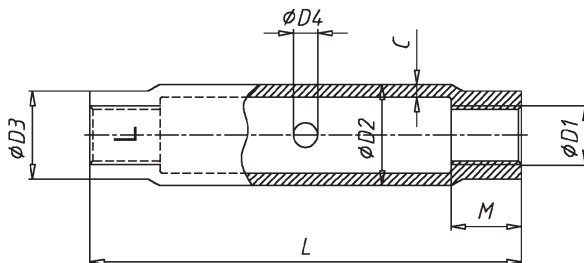

D1	M6	M8	M10	M12	M16	M20	M24	M30
P ¹⁾	1	1,25	1,5	1,75	2	2,5	3	3,5
D2	17,2	17,2	21,3	25	30	33,7	42,4	51
D3 min	9	12	15	18	22,5	27	32	38
D4	6	8	8	10	10	12	12	16
C	2,9	3,6	4	4	4,5	5	5,6	6,3
L	110	110	125	125	170	200	255	255
NSB ²⁾	90	85	95	90	120	140	180	160
M	7,5	10	12	15	20	24	29	36
Tragkraft (N)	2250	4100	6500	9300	17700	27000	39200	62500
VPE	1	1	1	1	1	1	1	1

Lieferbar in Stahl (ST35) sowie Edelstahl
Linksgewinde durch L gekennzeichnet.

Für Anschweißenden gilt im Regelfall die Festigkeit 3.6. Die axiale Belastbarkeit der Spannschlösser sollte sich deshalb mindestens nach diesen Anschlussteilen richten. Die angegebenen Tragkräfte gelten für eine übliche Verwendung der Anschweißenden. Die tatsächliche Belastbarkeit muss gegebenenfalls auch im Hinblick auf die verspannten Teile im Einzelfall rechnerisch ermittelt werden.

- Ausführung A Spannschlossmutter
- Ausführung B Spannschlossmutter mit Anschweißenden
- Ausführung C Spannschlossmutter mit Haken und Öse

¹⁾ Gewindesteigung
²⁾ Nachstellbarkeit ~

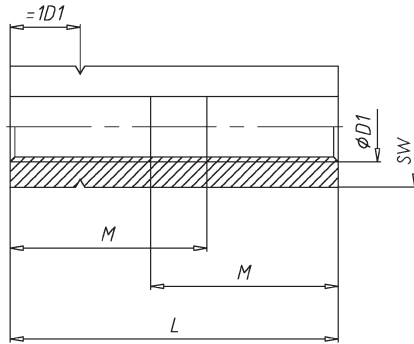

Maße in mm

D1	M6	M8	M10	M12	M16	M20	M24	M30
P ¹⁾	1	1,25	1,5	1,75	2	2,5	3	3,5
L	30	35	45	55	75	95	115	125
M	22,5	25	33	40	55	24	29	36
SW	10	13	16	18	24	30	36	46
NSB ²⁾	15	15	21	25	35	47	57	53
VPE	1	1	1	1	1	1	1	1

Lieferbar in Stahl sowie Edelstahl

Linksgewinde wahlweise durch L oder Rille über die Sechskantecken gekennzeichnet. Bis M16 mit überschrittenem Gewinde, ab M20 mit Aussparung.

Werkstoff: St 35, ab M56 aus St 50-2

¹⁾ Gewindesteigung

²⁾ Nachstellbarkeit ~





Maße in mm

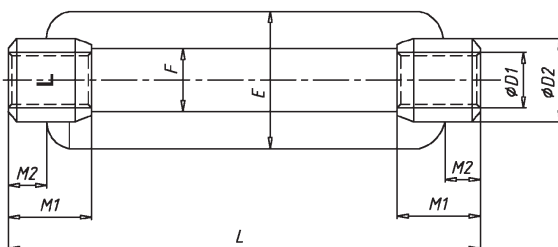

D1	M6	M8	M10	M12	M16	M20	M24	M30
P ¹⁾	1	1,25	1,5	1,75	2	2,5	3	3,5
D2	12	15	18	21	27	34	39	45
E	19	23	30	34	42	52	60	74
F	9	11	14	16	20	24	28	34
M1	12	15	18	21	27	34	39	45
M2	6	8	9	11	14	17	20	23
NSB ²⁾	80	75	85	80	110	130	170	160
L	110	110	125	125	170	200	255	255
Tragkraft (N)	2250	4100	6500	9300	17700	27000	39200	62500
VPE	1	1	1	1	1	1	1	1

Lieferbar in Stahl sowie Edelstahl
Linksgewinde durch L gekennzeichnet.

Für Anschweißenden gilt im Regelfall die Festigkeit 3.6. Die axiale Belastbarkeit der Spannschlösser sollte sich deshalb mindestens nach diesen Anschlussteilen richten. Die angegebenen Tragkräfte gelten für eine übliche Verwendung der Anschweißenden. Die tatsächliche Belastbarkeit muss gegebenenfalls auch im Hinblick auf die verspannten Teile im Einzelfall rechnerisch ermittelt werden.

Handelsübliche Ausführungen:

- Anschweißenden (beidseitig)
- Öse (beidseitig)
- Blattschrauben (beidseitig)
- Haken (beidseitig)
- Haken und Öse

¹⁾ Gewindesteigung

²⁾ Nachstellbarkeit ~

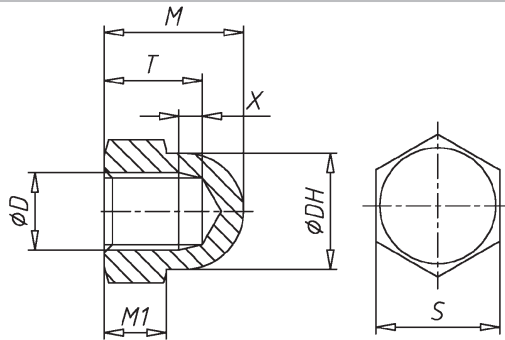

Maße in mm

D	M3 ²⁾	M4	M5	M6	M8	M10	M12	M14	M16	M20	M24
P ¹⁾	0,5	0,7	0,8	1	1,25	1,5	1,75	2	2	2,5	3
DH	5,5	6,5	7,5	9,5	12,5	15	17	14	23	28	34
M	6	8	10	12	15	18	22	20	28	34	42
M1	3	3,2	4	5	6,5	8	10	11	13	16	19
S	6	7	8	10	13	17	17	21	24	30	36
T min	4,26	5,26	7,21	7,71	10,65	12,65	15,65	17,65	20,58	25,58	30,5
X	1	1,4	1,6	2	2,5	3	0	0	0	0	0
VPE	1000	1000	1000	1000	500	500	200	100	50	25	25

Lieferbar in Güte: .6, Polyamid, Messing sowie Edelstahl A1 und Edelstahl A4

Bis 10 mm Gewinde- Nenndurchmesser mit Gewindefreistich oder Gewindeauslauf nach Wahl des Herstellers. Ab M12 mit Gewindefreistich.

¹⁾ Gewindesteigung

²⁾ nicht Bestandteil der DIN.





Maße in mm

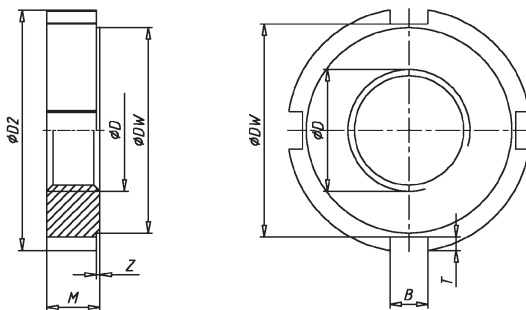

D	P ¹⁾	B	D2	DW	M	T	Z	VPE
M8X1	1	4	20	16	5	1,5	0,5	20
M10X1	1	5	25	20	6	1,5	0,5	20
M12X1,5	1,5	5	28	23	6	2	0,5	20
M14X1,5	1,5	5	30	25	7	2	0,5	20
M16X1,5	1,5	5	32	27	7	2	0,5	20
M18X1,5	1,5	6	34	28	8	2,5	0,5	20
M20X1,5	1,5	6	36	30	8	2,5	0,5	20
M22X1,5	1,5	6	40	34	9	2,5	0,5	20
M24X1,5	1,5	6	42	36	9	2,5	0,5	20
M26X1,5	1,5	7	45	38	10	3	0,5	10
M28X1,5	1,5	7	50	43	10	3	0,5	10
M30X1,5	1,5	7	50	43	10	3	0,5	10
M32X1,5	1,5	7	52	45	11	3	0,5	10
M35X1,5	1,5	7	55	48	11	3	0,5	10
M38X1,5	1,5	8	58	50	11	3,5	0,5	10
M40X1,5	1,5	8	62	54	12	3,5	0,5	5
M42X1,5	1,5	8	62	54	12	3,5	0,5	5
M45X1,5	1,5	8	68	60	12	3,5	0,5	5
M48X1,5	1,5	8	75	67	13	3,5	0,5	5
M50X1,5	1,5	8	75	67	13	3,5	0,5	5
M52X1,5	1,5	10	80	70	13	4	0,5	1
M55X1,5	1,5	10	80	70	13	4	0,5	1
M58X1,5	1,5	10	90	80	13	4	0,5	1
M60X1,5	1,5	10	90	80	13	4	0,5	1

D	P ¹⁾	B	D2	DW	M	T	Z	VPE
M62X1,5	1,5	10	95	85	14	4	0,5	1
M65X1,5	1,5	10	95	85	14	4	0,5	1
M68X1,5	1,5	10	100	90	14	4	0,5	1
M70X1,5	1,5	10	100	90	14	4	0,5	1
M72X1,5	1,5	10	110	100	14	4	0,5	1
M75X1,5	1,5	10	110	100	14	4	0,5	1
M80X2	2	10	115	105	16	4	1	1
M85X2	2	10	120	110	16	4	1	1
M90X2	2	10	130	120	16	4	1	1
M95X2	2	12	135	120	16	5	1	1
M100X2	2	12	145	130	16	5	1	1
M105X3	2	12	155	140	16	5	1	1

Lieferbar in Stahl sowie Edelstahl A2
 Ausführung W (ungehärtet) Ausführung H (gehärtet)
 Passende Sicherungsbleche finden sie unter DIN 462.

¹⁾ Gewindesteigung



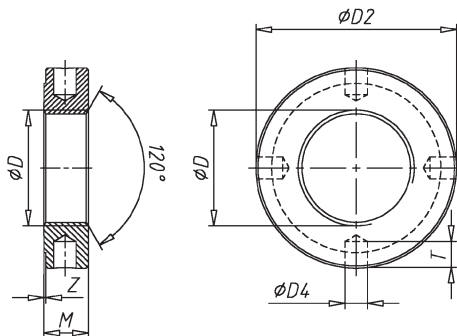

Maße in mm

D	M8	M10	M12	M14	M16	M18	M20	M22	M24	M26
P ¹⁾	1	1	1,5	1,5	1,5	1,5	1,5	1,5	1,5	1,5
D2	20	25	28	30	32	34	36	40	42	45
D4	2,5	3	3	4	4	4	4	4	4	5
M	5	6	6	7	7	8	8	9	9	10
VPE	10	10	10	10	10	10	10	10	10	5

D	M28	M30	M32	M35	M38	M40	M42	M48	M50	M52	M55
P ¹⁾	1,5	1,5	1,5	1,5	1,5	1,5	1,5	1,5	1,5	1,5	1,5
D2	50	50	52	55	58	62	62	75	75	80	80
D4	5	5	5	5	5	6	6	6	6	6	6
M	10	10	11	11	11	12	12	13	13	13	13
VPE	5	5	5	5	5	5	1	1	1	1	1

Lieferbar in Stahl
 Ausführung W (ungehärtet) Ausführung H (gehärtet)

¹⁾ Gewindesteigung

Maße in mm

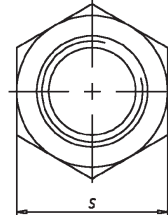
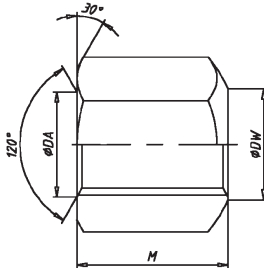

D	M6	M8	M10	M12	M16	M20	M24	M30	M36	M42	M48
P ¹⁾	1	1,25	1,5	1,75	2	2,5	3	3,5	4	4,5	5
DW	7	9	11,5	14	18	22	26	32	38	44	52
M	9	12	15	18	24	30	36	45	54	63	72
S	10	13	16	18	24	30	36	46	55	65	75
VPE	100	100	100	100	50	25	25	10	5	5	5

Diese Sechskantmuttern werden für Schraubenverbindungen verwendet, die häufig angezogen und gelöst werden. Die kugelige Auflagefläche gestattet bei Anwendung einer Kegelsenkung von 120° oder einer Kegelpfanne nach DIN 6319 um Lageabweichungen bei Spannelementen auszugleichen.

Lieferbar in Güte: .10 sowie Edelstahl A2

Form B: mit einseitiger kugelliger Auflagefläche

¹⁾ Gewindesteigung



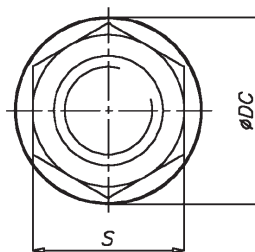
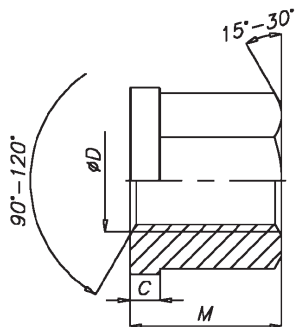

Maße in mm

D	M6	M8	M10	M12	M16	M20	M24	M27	M30	M36
P ¹⁾	1	1,25	1,5	1,75	2	2,5	3	3	3,5	4
C	3	3,5	4	4	5	6	6	7	8	10
DC	14	18	22	25	31	37	45	50	58	68
M	9	12	15	18	24	30	36	40	45	54
S	10	13	16	18	24	30	36	41	46	55
VPE	200	200	100	100	50	25	25	10	10	10

Lieferbar in Güte: .10 sowie Edelstahl A2

¹⁾ Gewindesteigung

Maße in mm

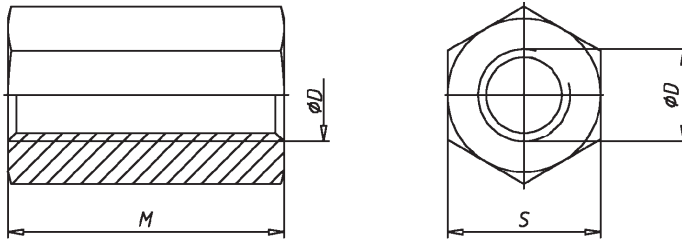

D	M6	M8	M10	M12	M16	M20	M24
P ¹⁾	1	1,25	1,5	1,75	2	2,5	3
M	18	24	30	36	48	60	72
S	10	13	17	19	24	30	36
VPE	100	100	100	100	25	20	10

Lieferbar in Güte: .10

¹⁾ Gewindesteigung



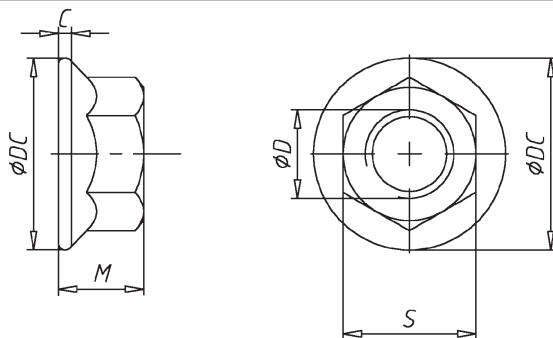

Maße in mm

D	M5	M6	M8	M10	M12	M14	M16	M20
P ¹⁾	0,8	1	1,25	1,5	1,75	2	2	2,5
DC max	11,8	14,2	17,9	21,8	26	29,9	34,5	42,8
C	1	1,1	1,2	1,5	1,8	2,1	2,4	3
M max	5	6	8	10	12	14	16	20
S	8	10	13	15	18	21	24	30
VPE	1000	1000	1000	500	250	100	100	50

Lieferbar in Güte: .8 sowie Edelstahl A2

¹⁾ Gewindesteigung

Maße in mm

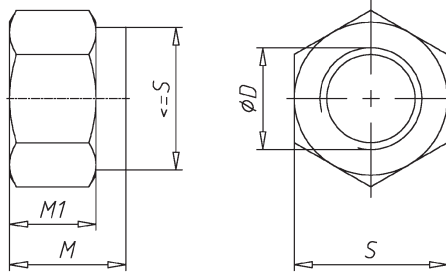

D	M5	M6	M8	M10	M12	M16	M20
P ¹⁾	0,8	1	1,25	1,5	1,75	2	2,5
M max	6,8	8	9,5	11,9	14,9	19,1	22,8
M1	4,4	4,9	6,44	8,04	10,37	14,1	16,9
S	8	10	13	16	18	24	30
VPE	1000	1000	1000	500	250	100	50

Lieferbar in Güte: .8
Gestaltung des Klemmteils nach Wahl des Herstellers.

¹⁾ Gewindesteigung





Maße in mm

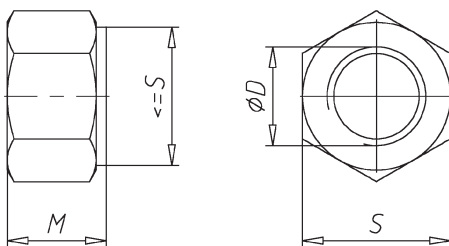

D	M6	M8	M10	M12	M16	M20	M24
P ¹⁾	1	1,25	1,5	1,75	2	2,5	3
M	6	8	10	12	16	20	24
S	10	13	16	18	24	30	36
VPE	1000	500	200	200	50	50	50

Lieferbar in Güte: .8
Gestaltung des Klemmteils nach Wahl des Herstellers.

¹⁾ Gewindesteigung

Maße in mm

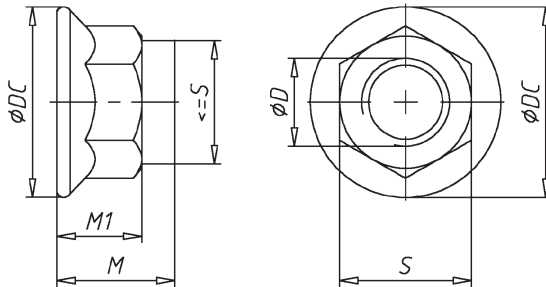

D	M5	M6	M8	M10	M12	M16	M20
P ¹⁾	0,8	1	1,25	1,5	1,75	2	2,5
DC max	11,8	14,2	17,9	21,8	26	34,5	42,8
M max	7,1	9,1	11,1	13,5	16,1	20,3	24,8
M1	4,7	5,7	7,6	9,6	11,6	15,3	18,9
S	8	10	13	15	18	24	30
VPE	1000	1000	1000	500	250	100	100

Lieferbar in Güte: .8
Gestaltung des Klemmteils nach Wahl des Herstellers.

¹⁾ Gewindesteigung





Maße in mm

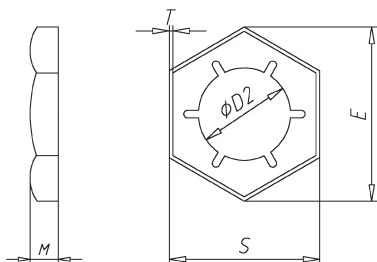

D	M4	M5	M6	M8	M10	M12	M14
P ¹⁾	0,7	0,8	1	1,25	1,5	1,75	2
D2	3,5	4,5	5,3	6,9	8,6	10,4	12
E	8,1	9,2	11,5	15	19,6	21,9	25,4
M	2,5	2,5	3	3,5	4	4,5	5
S	7	8	10	13	17	19	22
T	0,3	0,4	0,4	0,5	0,5	0,6	0,6
VPE	1000	1000	1000	1000	500	500	500

D	M16	M18	M20	M22	M24	M27	M30	M36
P ¹⁾	2	2,5	2,5	2,5	3	3	3,5	4
D2	14,1	15,5	17,6	19,6	21	24,2	26,6	32,2
E	27,7	31,2	34,6	36,9	41,6	47,3	53,1	63,5
M	5	5,5	6	6	7	7	8	9
S	24	27	30	32	36	41	46	55
T	0,7	0,7	0,8	0,8	0,9	1	1,1	1,3
VPE	250	250	250	100	100	100	100	50

Anziehen der Sicherungsmutter:

Sicherungsmutter handfest aufschrauben, dann mit einem Schraubenschlüssel 1/4 bis 1/2 Umdrehung anziehen.

Lösen der Sicherungsmutter:

Sechskantmutter kräftig anziehen, damit die Federwirkung der Sperrzähne aufgehoben wird. Die Sicherungsmutter lässt sich dann leicht lösen.

Lieferbar in Stahl sowie Edelstahl A2

Auch für Feingewinde lieferbar.

¹⁾ Gewindesteigung

Maße in mm

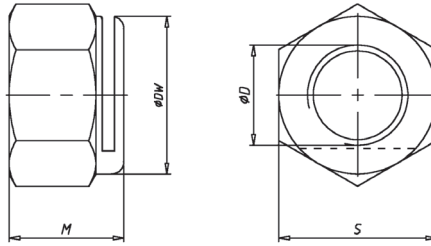

D	M8	M10	M12
DW	12,5	16,5	18,5
M	8,5	10,5	12,5
S	13	17	19
VPE	100	100	100

Lieferbar in Stahl verkupfert
 Geeignet für Temperaturen von -70°C bis +400°C





Maße in mm

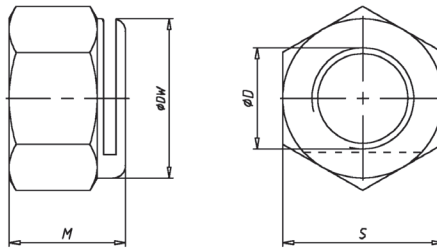

D	M6	M8	M10	M12
DW	8,5	11,5	13,5	16,5
M	7	8,5	10,5	12,5
S	9	12	14	17
VPE	100	100	100	100

Lieferbar in Stahl verkupfert
Geeignet für Temperaturen von -70°C bis +400°C

Maße in mm

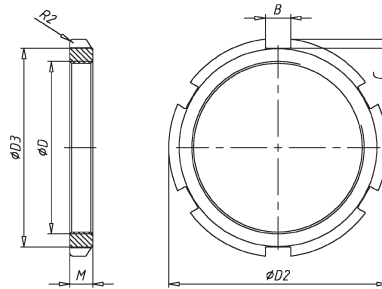

D	M10	M12	M14	M16	M18	M20	M22	M24	M26
P ¹⁾	1	1,5	1,5	1,5	1,5	1,5	1,5	1,5	1,5
B	4,5	4,5	4,5	5,5	5,5	5,5	6,5	6,5	6,5
C	1,8	1,8	1,8	2,3	2,3	2,3	2,8	2,8	2,8
D2	20	22	24	28	30	32	36	38	40
D3	16	18	20	23	25	27	30	32	34
M	5	6	6	6	6	6	7	7	7
VPE	1	1	1	1	1	1	1	1	1

D	M28	M30	M32	M35	M38	M40	M42	M45	M48	M50
P ¹⁾	1,5	1,5	1,5	1,5	1,5	1,5	1,5	1,5	1,5	1,5
B	6,5	6,5	7	7	7	7	8	8	8	8
C	2,8	2,8	3,3	3,3	3,3	3,3	3,8	3,8	3,8	3,8
D2	42	44	48	50	54	56	60	62	65	68
D3	36	38	41	43	47	49	52	54	57	60
M	7	7	8	8	8	8	8	8	8	8
VPE	1	1	1	1	1	1	1	1	1	1

Lieferbar in Stahl

¹⁾ Gewindesteigung



Maße in mm

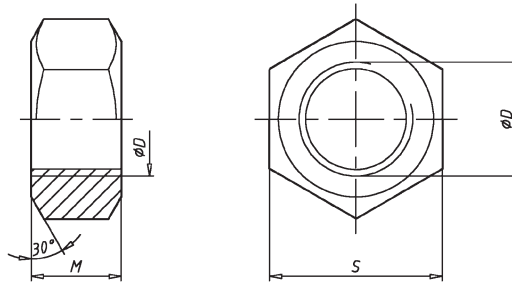

D	M3	M4	M5	M6	M8	M10	M12	M16	M20	M24	M30	M36
P ¹⁾	0,5	0,7	0,8	1	1,25	1,5	1,75	2	2,5	3	3,5	4
M max	2,4	3,2	4,7	5,2	6,8	8,4	10,8	14,8	18	21,5	25,6	31
S	5,5	7	8	10	13	16	18	24	30	36	46	55
VPE	1000	1000	1000	1000	1000	500	200	200	100	50	50	25

Lieferbar in Güte: .5-2, .8, .10, .12, Messing, Aluminium, Polyamid sowie Edelstahl A2 und Edelstahl A4
Auch mit Feingewinde lieferbar.

¹⁾ Gewindesteigung

Maße in mm

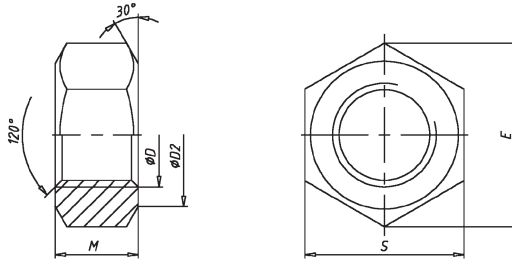

D	M12	M16	M20	M24	M27	M30	M36
P ¹⁾	1,75	2	2,5	3	3	3,5	4
D2	20	25	30	39	43,5	47,5	57
M	10	13	16	19	22	24	29
S	22	27	32	41	46	50	60
E	23,91	29,56	35,03	45,2	50,85	55,37	66,44
VPE	200	100	100	50	50	50	25

Lieferbar in Güte: .10

¹⁾ Gewindesteigung





1



2



3



4



5



6



7



8



9

Maße in mm

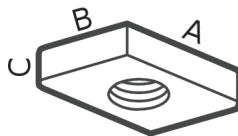

Nennmaß	A	B	C	für Profile	VPE
20/12 M5	16	9	4	20/12	200
20/12 M6	16	9	4	20/12	200
28/15 M6	24,5	13	4	28/28, 28/15, 28/12, 26/26, 26/18	200
28/15 M8	24,5	13	4	28/28, 28/15, 28/12, 26/26, 26/18	200
28/15 M10	33,5	17,5	5	28/28, 28/15, 28/12, 26/26, 26/18	200
38/17 M6	33,5	17,5	6	38/17, 36/20, 35/50, 36/36	100
38/17 M8	33,5	17,5	6	38/17, 36/20, 35/50, 36/36	100
38/17 M10	33,5	17,5	6	38/17, 36/20, 35/50, 36/36	100
38/17 M12	33,5	17,5	6	38/17, 36/20, 35/50, 36/36	100
40/22 M5	34,5	17	10	40/22, 40/25	100
40/22 M6	34,5	17	10	40/22, 40/25	100
40/22 M8	34,5	17	10	40/22, 40/25	100
40/22 M10	34,5	17	10	40/22, 40/25	100
40/22 M12	34,5	17	11,5	40/22, 40/25	100
41/22 M6	34,5	20	7,5	41/22, 41/41	100
41/22 M8	34,5	20	7,5	41/22, 41/41	100
41/22 M10	34,5	20	7,5	41/22, 41/41	100
41/22 M12	34,5	20	7,5	41/22, 41/41	100
41/22 M16	34,5	20	7,5	41/22, 41/41	100
41/41 M6	34,5	20	6	41/41 D, 41/62 D, 41/83	100
41/41 M8	34,5	20	8	41/41 D, 41/62 D, 41/83	100
41/41 M10	34,5	20	9	41/41 D, 41/62 D, 41/83	100
41/41 M12	34,5	20	11	41/22, 41/22 D	100

Nennmaß	A	B	C	für Profile	VPE
50/30 M8	43,5	21	12	52/34, 54/33, 50/30, 49/30, 50/40	100
50/30 M10	43,5	21	12	52/34, 54/33, 50/30, 49/30, 50/40	100
50/30 M12	43,5	21	12	52/34, 54/33, 50/30, 49/30, 50/40	100
50/30 M16	43,5	21	12	52/34, 54/33, 50/30, 49/30, 50/40	100
50/40 M6	41,5	20,5	8	50/40, 486	100
50/40 M8	41,5	20,5	8	50/40, 486	100
50/40 M10	41,5	20,5	8	50/40, 486	50
50/40 M12	41,5	20,5	8	50/40, 486	50
50/40 M16	41,5	20,5	8	50/40, 486	50
72/48 M12	62	31	22	72/48, 72/49	50
72/48 M16	62	31	22	72/48, 72/49	50
72/48 M20	62	31	22	72/48, 72/49	50

Maße vorbehaltlich produktionsbedingter Änderungen.
Lieferbar in Stahl, Edelstahl A2 sowie Edelstahl A4

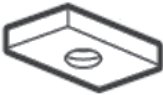
20/12

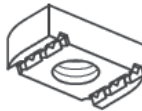
40/22

41/22

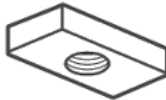
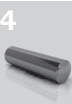
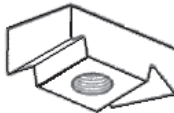
41/41

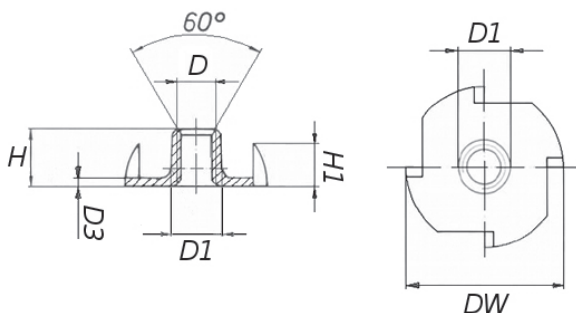
50/30

50/40

72/48



Maße in mm

Nennmaß	D	D1	D3	DW	H	H1	VPE
M3x5	3	4,3	0,8	13	5	3,5	500
M4x6	4	5,3	0,8	15	6	4,5	500
M4x8	4	5,3	0,8	15	8	4,5	500
M5x6	5	5,9	1	17	6	5,5	500
M5x8	5	6,3	1	17	8	5,5	500
M5x12	5	6,5	1,1	17	12	5,5	500
M6x9	6	7,3	1,25	19	9	7	500
M6x12	6	7,5	1,25	19	12	7	500
M8x11	8	9,0	1,25	19	11	7,5	200
M8x17	8	9,7	1,5	22	17	14,5	200
M10x12	10	11,9	1,5	25	12	9	200
M10x13	10	11,9	1,8	25	13	9	200
M12x14	12	13,7	1,8	27	14	9,5	200

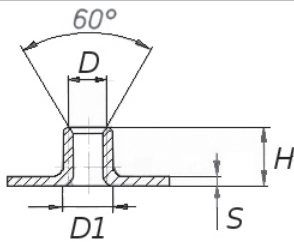
Maße vorbehaltlich produktionsbedingter Änderungen.
 Lieferbar in Stahl sowie Edelstahl A2



Maße in mm

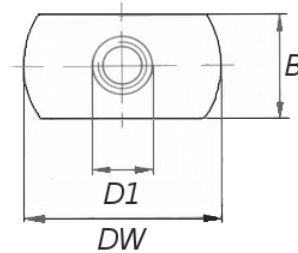

Nennmaß	D	D1	B	DW	S	VPE
CM5x7,5	5	6,4	11	19	1,2	500
CM6x7,5	6	7,3	11	19	1,2	500
CM6x8,5	6	7,7	14	22	1,45	500
CM8x8,5	8	9,5	14	22	1,45	200
CM8x10	8	10,1	18	26	1,8	200
CM10x10,5	10	11,9	18	26	1,9	200
CM12x12,5	12	14,3	20,5	29	2,2	200

Lieferbar in Stahl

Maße vorbehaltlich produktionsbedingter Änderungen. Bei schweißtechnischen Fragen wenden Sie sich bitte an den Hersteller Ihrer Schweißanlage.

Werkstoff: Kaltband ohne Überzug aus weichen Stählen zum Kaltumformen EN 10139 (DIN 1624)

Weitere Formen lieferbar:

Form A - Schweißbuckel unten



Form B - Schweißbuckel oben



Form D - mit Bohrung



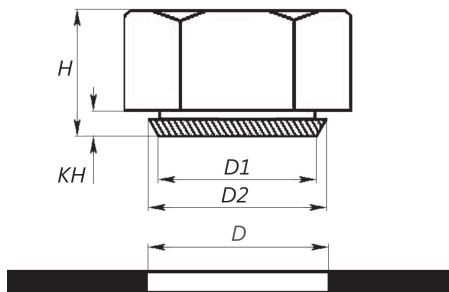

Maße in mm

Nennmaß	B ¹⁾	D ²⁾	D1	D2	H	KH ³⁾	SW ⁴⁾	VPE
M2 Kh 0,9	1	4,5	4,5	4,7	3	0,9	5,5	1000
M2 Kh 1,4 ⁵⁾	1,5	4,5	4,5	4,7	3,5	1,4	5,5	1000
M2 Kh 1,8 ⁵⁾	2	4,5	4,5	4,7	3,9	1,8	5,5	1000
M2,5 Kh 0,9	1	4,5	4,5	4,7	3	0,9	5,5	200
M2,5 Kh 1,4 ⁵⁾	1,5	4,5	4,5	4,7	3,5	1,4	5,5	200
M2,5 Kh 1,8 ⁵⁾	2	4,5	4,5	4,7	3,9	1,8	5,5	200
M3 Kh 0,9	1	4,5	4,5	4,7	3	0,9	5,5	200
M3 Kh 1,4 ⁵⁾	1,5	4,5	4,5	4,7	3,5	1,4	5,5	200
M3 Kh 1,8 ⁵⁾	2	4,5	4,5	4,7	3,9	1,8	5,5	200
M4 Kh 0,9	1	5,5	5,5	5,7	3,2	0,9	7	200
M4 Kh 1,4 ⁵⁾	1,5	5,5	5,5	5,7	3,7	1,4	7	200
M4 Kh 1,8 ⁵⁾	2	5,5	5,5	5,7	4	1,8	7	200
M5 Kh 0,9	1	6,5	6,5	6,75	4	0,9	8	200
M5 Kh 1,4 ⁵⁾	1,5	6,5	6,5	6,75	4,5	1,4	8	200
M5 Kh 1,8 ⁵⁾	2	6,5	6,5	6,75	4,9	1,8	8	200
M6 Kh 0,9	1	8	8	8,3	5	0,9	10	200
M6 Kh 1,4 ⁵⁾	1,5	8	8	8,3	5	1,4	10	200
M6 Kh 1,8 ⁵⁾	2	8	8	8,3	5	1,8	10	200
M8 Kh 1,8	2	10	10	10,3	6,5	1,8	13	100
M10 Kh 1,8	2	12,5	12,5	12,85	8	1,8	15	100
M12 Kh 2,9	3	14,5	14,5	14,85	10	2,8	17	100
M16 Kh 2,4	3	18,5	18,5	18,85	13	2,4	22	100
M20 Kh 3,9	4	23	23	23,4	16	3,9	27	50

Lieferbar inStahl (1.0718) sowie Edelstahl A2 (1.4305)

Setzmuttern werden in dünnwandigen Blech- und Kunststoffteilen eingepresst. Auch als Kalei-Setzmutter N0303 lieferbar.

¹⁾ Materialstärke (min.) ²⁾ Bohrloch (H11) ³⁾ Kragenhöhe ⁴⁾ Schlüsselweite ⁵⁾ Sonderausführung

Maße in mm

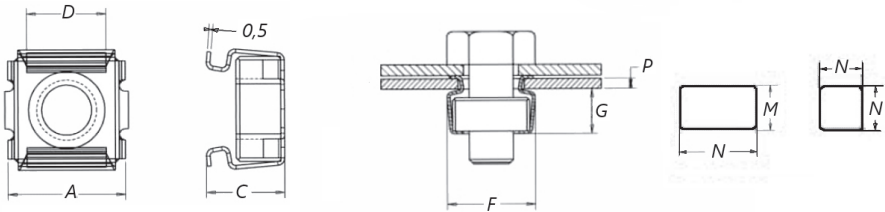

Nennmaß	D	A	G	C	F	N	M	P ¹⁾	VPE
M4-4SMG	8,7	13,1	4,6	6,9	13,5	9,5	9,2	0,7-1,7	500
M4-8SMG	8,7	13,1	4,6	7,9	13,5	9,5	9,2	1,8-2,6	500
M5-4SMG	8,7	13,1	4,6	6,9	13,5	9,5	9,2	0,7-1,7	500
M5-6SMG	8,8	13,1	6,4	8,7	13,8	9,5	9,2	0,7-1,7	500
M5-8SMG	6,7	13,9	6,3	9,6	13,7	9,5	9,2	1,8-2,6	500
M6-4SMG	8,7	13,1	4,6	6,9	13,5	9,5	9,2	0,7-1,7	200
M6-6SMG	8,8	13,4	6,4	8,7	13,8	9,5	9,2	0,7-1,7	200
M6-8SMG	8,9	13,8	6,3	10,1	13,7	9,5	9,2	1,8-2,6	200
M8-8SMG	11,4	16,6	7,4	10,9	17,8	12,3	12,1	1,8-2,6	200

Lieferbar in Stahl sowie Edelstahl

Diese Muttern werden einfach an der Rückseite des Aufnahmebleches eingeklipst. Sie lassen sich mit sehr unterschiedlichen Blechstärken verarbeiten. Sie lassen sich ebenfalls in Hohlräumen mit weiter seitlicher Verschiebung verwenden. Die Mutter schwimmt im Käfig und gleicht so Positionsfehler aus.

¹⁾ Blechstärke

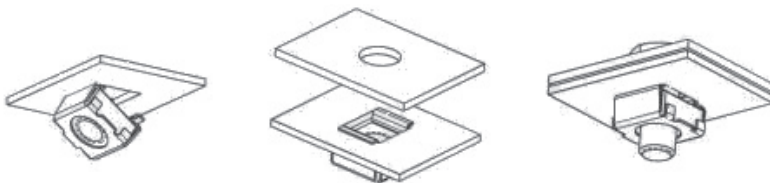



Maße in mm

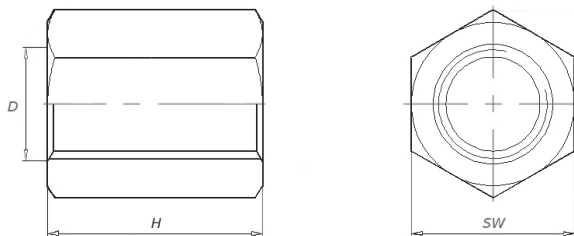

Nennmaß	D	P ¹⁾	H	SW	VPE
6kt TR 10x3	10	TR 10X3	15	17	1
6kt TR 12x3	12	TR 12X3	18	19	1
6kt TR 14x4	14	TR 14X4	21	22	1
6kt TR 16x4	16	TR 16X4	24	27	1
6kt TR 18x4	18	TR 18X4	27	27	1
6kt TR 20x4	20	TR 20X4	30	30	1
6kt TR 22x5	22	TR 22X5	33	30	1
6kt TR 24x5	24	TR 24X5	36	36	1
6kt TR 26x5	26	TR 26X5	39	36	1
6kt TR 28x5	28	TR 28X5	42	41	1
6kt TR 30x6	30	TR 30X6	45	46	1
6kt TR 36x6	36	TR 36X6	54	55	1
6kt TR 40x7	40	TR 40X7	60	65	1
6kt TR 44x7	44	TR 44X7	66	65	1
6kt TR 48x8	48	TR 48X8	72	75	1
6kt TR 50x8	50	TR 50X8	75	75	1

Maße vorbehaltlich produktionsbedingter Änderungen.

¹⁾ Gewinde

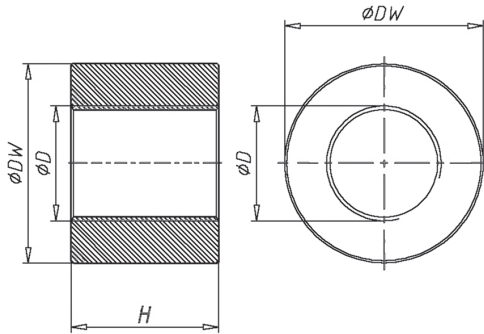

Maße in mm

Nennmaß	D	P ¹⁾	H	DW	VPE
RU TR 10x3	10	TR 10X3	15	22	1
RU TR 12x3	12	TR 12X3	18	22	1
RU TR 14x4	14	TR 14X4	21	30	1
RU TR 16x4	16	TR 16X4	24	36	1
RU TR 18x4	18	TR 18X4	27	36	1
RU TR 20x4	20	TR 20X4	30	36	1
RU TR 22x5	22	TR 22X5	33	50	1
RU TR 24x5	24	TR 24X5	36	50	1
RU TR 26x5	26	TR 26X5	39	50	1
RU TR 28x5	28	TR 28X5	42	60	1
RU TR 30x6	30	TR 30X6	45	60	1
RU TR 32x6	32	TR 32X6	48	60	1
RU TR 36x6	36	TR 36X6	54	75	1
RU TR 40x7	40	TR 40X7	60	75	1
RU TR 44x7	44	TR 44X7	66	75	1
RU TR 48x8	48	TR 48X8	72	75	1
RU TR 50x8	50	TR 50X8	75	75	1

Maße vorbehaltlich produktionsbedingter Änderungen.

¹⁾ Gewinde





Maße in mm

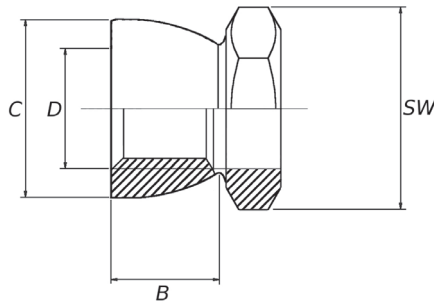

D	M6	M8	M10	M12	M16	M20
B	5	6	8	10	13	18
C	10	13	17	19	24	30
SW	10	13	17	19	24	30
Abreißmoment	10-15 Nm	13-25 Nm	30-38 Nm	37-45 Nm	45-60 Nm	65-80 Nm
VPE	100	100	100	100	100	100

Durch das aufbringen des angegebenen Anziehdrehmoments kommt es zum Abbrechen des Sechskanteils. Es bleibt eine konische Mutter zurück, die sich mit Standardwerkzeug nicht mehr demontieren lässt.

Maße vorbehaltlich produktionsbedingter Änderungen.

Lieferbar in Edelstahl A2

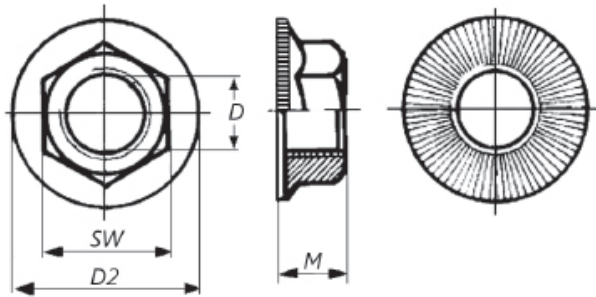

Maße in mm

D	M5	M6	M8	M10	M12	M16
P ¹⁾	0,8	1	1,25	1,5	1,75	2
D2	11,2	14,2	18,2	21	24	31
M	4,3	5,5	7,0	8,5	10	14
SW	8	10	13	15	17	22
VPE	500	500	500	500	200	100

Lieferbar in Stahl Güte: 10

Statt herkömmlicher Sperrzähne hat die Ripp-Sicherungsmutter gerundete Rippen. Vorteile sind:

- Verschraubung auf rauen Oberflächen
- Keine Spanbildung möglich
- weitgehende Erhaltung des Korrosionsschutzes an der Verbindungsstelle
- ausgezeichnete Sicherungswirkung auf harten Werkstoffen
- Keine Kerbwirkung bei der Verschraubung dünner Bleche
- keine Unterlegscheiben nötig

¹⁾ Gewindesteigung



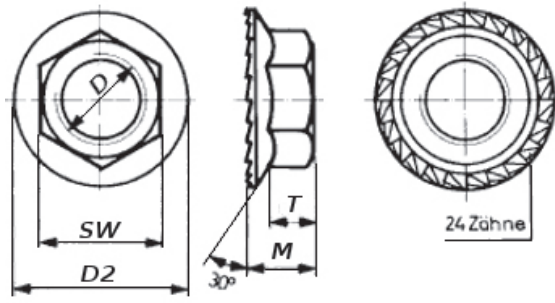

Maße in mm

D	M5	M6	M8	M10	M12	M16
P ¹⁾	0,8	1	1,25	1,5	1,75	2
D2	11,2	14,25	18,25	21	24	31
M	4,3	5,3	7	7,9	8,7	11,2
T	2,55	3,3	4,4	5,1	5,4	7,35
SW	8	10	13	15	17	22
VPE	500	500	500	200	200	100

Lieferbar in Stahl Güte: 10

Die Sicherungsmuttern mit Sägezahnprofil ermöglichen hohe Vorspannkkräfte - ein zusätzlicher Schutz gegen Lockern und Losdrehen. Die Sicherung erfolgt durch 24 Verriegelungszähne. Da sich die Zähne um die Zahntiefe in das Gegenmaterial eingraben, ist hier eine gewisse Oberflächenbeschädigung im Bereich der Zähne gegeben, insbesondere wenn die Mutter wieder gelöst wird, da dann das Material um die Eindringtiefe der Zähne abgefräst wird. Sofern Sie eine Oberflächenbeschädigung vermeiden müssen, empfehlen wir Ihnen in solchen Fällen die Sicherungsmuttern mit Wellenprofil.

¹⁾ Gewindesteigung



1



2



3



4



5



6



7



8



9





Maße in mm

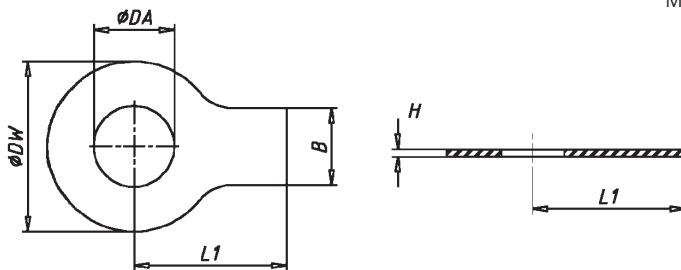

DA	3,2	4,3	5,3	6,4	8,4	10,5	13	15	17				
DW	12	14	17	19	22	26	30	33	36				
B	4	5	6	7	8	10	12	12	15				
H	0,38	0,38	0,5	0,5	0,75	0,75	1	1	1				
L1	13	14	16	18	20	22	28	28	32				
VPE	100	100	100	100	100	100	100	100	100				
DA	19	21	23	25	28	31	34	37	40	43	46	50	
DW	40	42	50	50	58	63	68	75	82	88	95	100	
B	18	18	20	20	23	26	28	30	32	35	38	40	
H	1	1	1	1	1,6	1,6	1,6	1,6	1,6	1,6	1,6	1,6	
L1	36	36	42	42	48	52	56	60	64	70	75	80	
VPE	100	100	100	100	100	50	50	50	25	25	25	25	

Lieferbar in Stahl sowie Edelstahl A2

Maße in mm

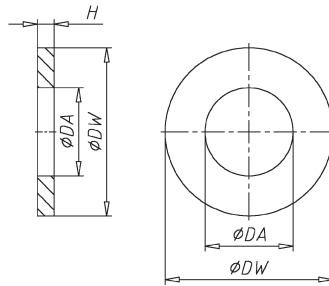

DA	2,2	2,5	2,7	3,2	3,7	4,3	5,3	6,4	7,4					
DW	5	6	6	7	8	9	10	12	14					
H	0,3	0,5	0,5	0,5	0,5	0,8	1	1,6	1,6					
VPE	1000	1000	1000	1000	1000	1000	1000	1000	1000					
DA	8,4	10,5	13	15	17	19	21	23	25	27				
DW	16	20	24	28	30	34	37	39	44	50				
H	1,6	2	2,5	2,5	3	3	3	3	4	4				
VPE	1000	500	500	250	200	200	200	200	200	50				
DA	28	31	34	36	37	40	41	43	46	50	52	54	58	60
DW	50	56	60	66	66	72	72	78	85	92	92	98	105	110
H	4	4	5	5	5	6	6	7	7	8	8	8	9	9
VPE	50	50	50	50	50	25	25	25	25	20	20	20	10	10

Form A: ohne Fase

Form B: mit Außenfase

Lieferbar in Stahl (140 HV), Polyamid, Messing, Hartpapier sowie in Edelstahl A2 und Edelstahl A4



Maße in mm

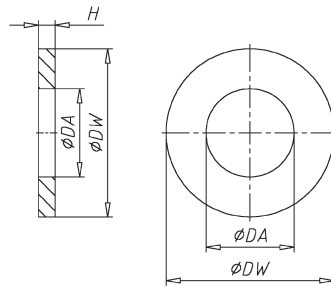

DA	5,5	6,6	9	11	13,5	15,5	17,5	20	22		
DW	10	12	16	20	24	28	30	34	37		
H	1	1,6	1,6	2	2,5	2,5	3	3	3		
VPE	200	200	200	200	200	200	200	100	100		
DA	24	26	30	33	36	39	42	45	48	52	56
DW	39	44	50	56	60	66	72	78	85	92	98
H	3	4	4	4	5	5	6	7	7	8	8
VPE	100	100	100	50	50	50	50	25	25	25	25

Lieferbar in Stahl (100 HV)

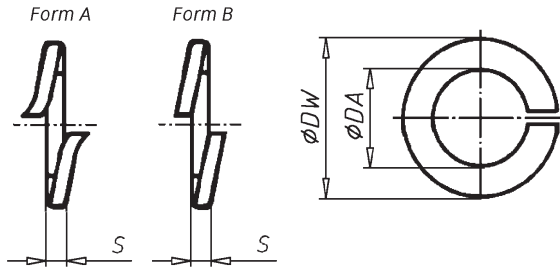

Maße in mm

Nennmaß	B2	B2,5	B3	B3,5	B4	B5	B6	B7	B8	B10
DA max	2,4	2,9	3,4	3,9	4,4	5,4	6,5	7,5	8,5	10,7
DW max	4,4	5,1	6,2	6,7	7,6	9,2	11,8	12,8	14,8	18,1
S	0,5	0,6	0,8	0,8	0,9	1,2	1,6	1,6	2	2,2
VPE	1000	1000	1000	1000	1000	1000	1000	1000	1000	500

Nennmaß	B12	B14	B16	B18	B20	B22	B24	B27	B30	B36	B39	B42
DA max	12,7	14,7	17	19	21,2	23,5	25,5	28,5	31,7	37,7	40,7	43,7
DW max	21,1	24,1	27,4	29,4	33,6	35,9	40	43	48,2	58,2	61,2	68,2
S	2,5	3	3,5	3,5	4	4	5	5	6	6	6	7
VPE	500	500	250	250	100	100	100	100	50	50	50	50

Form A: aufgebogen

Form B: glatt

Lieferbar in Stahl sowie NIRO





Maße in mm

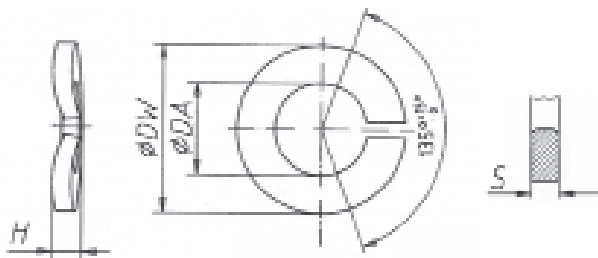

Nennmaß	A3	A4	A5	A6	A8	A10	A12	A14	A16	A20	A22	A24
DA	3,4	4,4	5,4	6,5	8,5	10,7	12,7	14,7	17	21,2	23,5	25,5
DW	6,2	7,6	9,2	11,8	14,8	18,1	21,1	24,1	27,4	33,6	35,9	40
H	1,3	1,5	1,8	2,5	3	3,5	4	4,9	5	6	6	7
S	0,7	0,8	1	1,3	1,6	1,8	2,1	2,4	2,8	3,2	3,2	4
VPE	1000	1000	1000	1000	1000	1000	500	500	250	100	100	100

Lieferbar in Stahl sowie NIRO

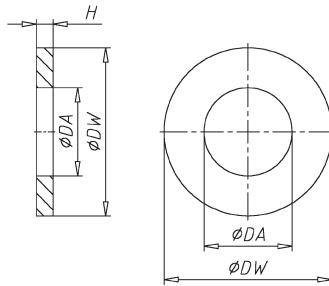

Maße in mm

DA	3,2	4,3	5,3	6,4	8,4	10,5	13	17	21
DW	8	10	12	14	18	22	28	34	40
H	0,5	0,8	0,8	1,5	2	2,5	3	3	4
VPE	1000	1000	1000	1000	1000	1000	500	250	250

Lieferbar in Stahl sowie Edelstahl A2





Maße in mm

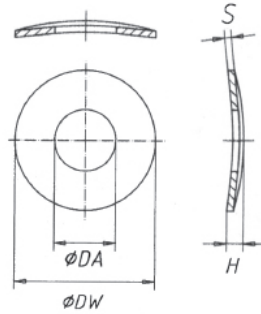

DA	2,2	2,8	3,2	3,7	4,3	5,3	6,4	7,4	8,4	10,5
DW	4,5	5,5	6	7	8	10	11	12	15	18
H	1	1,1	1,3	1,4	1,6	1,8	2,2	2,4	3,4	4
S	0,3	0,3	0,4	0,4	0,5	0,5	0,5	0,5	0,5	0,8
VPE	1000	1000	1000	1000	1000	1000	1000	1000	1000	1000

Lieferbar in Stahl sowie NIRO

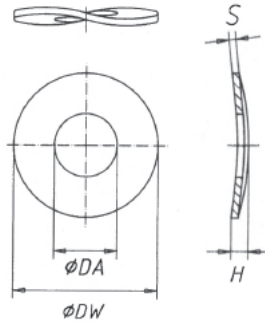

Maße in mm

DA	3,2	3,7	4,3	5,3	6,4	7,4			
DW	8	8	9	11	12	14			
H	0,8	0,9	1	1,1	1,3	1,5			
S	0,5	0,5	0,5	0,5	0,5	0,8			
VPE	1000	1000	1000	1000	1000	1000			
DA	8,4	10,5	13	15	17	19	21	23	25
DW	15	21	24	28	30	34	36	40	44
H	1,5	2,1	2,5	3	3,2	3,3	3,7	3,9	4,1
S	0,8	1	1,2	1,6	1,6	1,6	1,6	1,8	1,8
VPE	1000	1000	500	500	250	250	250	100	100

Lieferbar in Stahl sowie NIRO



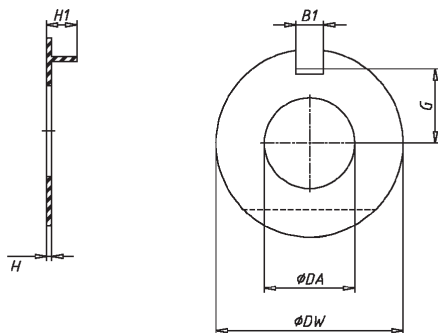

Maße in mm

DA	6,4	8,4	10,5	13	15	17	19	21		
DW	19	22	26	30	33	36	40	42		
B1	3,5	3,5	4,5	4,5	4,5	5,5	6,5	6,5		
G	7,5	8,5	10	12	13	15	18	18		
H	0,75	1	1	1,2	1,2	1,2	1,2	1,6		
H1	3	4	4	4,5	4,5	4,5	4,5	4,5		
VPE	500	500	200	200	200	200	200	200		
DA	23	25	28	31	34	37	40	43	46	50
DW	50	50	58	63	68	75	82	88	95	100
B1	7,5	7,5	8,5	8,5	9,5	11	11	11	13	13
G	20	21	23	25	28	31	33	36	38	40
H	1,6	1,6	1,6	1,6	1,6	2	2	2	2	2
H1	6,5	6,5	9,5	9,5	9,5	9,5	11	11	12	13
VPE	50	50	50	50	50	50	25	25	25	25

Lieferbar in Stahl sowie Edelstahl A2 und Edelstahl A4

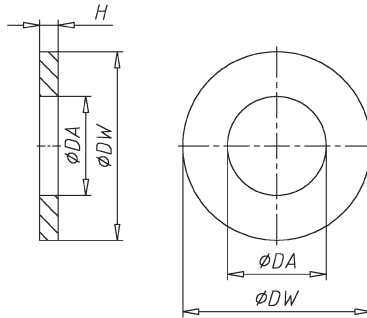

Maße in mm

DA	2,2	2,7	3,2	3,7	4,3	5,3	6,4	8,4
DW	4,5	5	6	7	8	9	11	15
H	0,3	0,5	0,5	0,5	0,5	1	1,6	1,6
VPE	1000	1000	1000	1000	1000	1000	1000	1000
DA	10,5	13	15	17	19	21	25	31
DW	18	20	24	28	30	34	39	50
H	1,6	2	2,5	2,5	2,5	3	4	4
VPE	500	500	250	250	250	250	100	100

Lieferbar in Stahl (140HV), Messing sowie Edelstahl A2 und Edelstahl A4

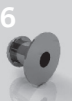
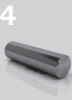

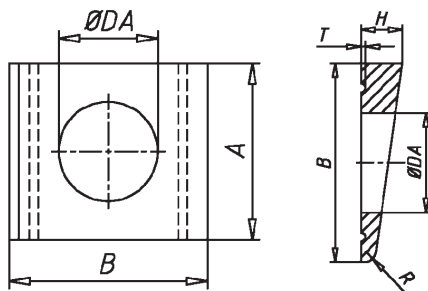

Maße in mm

DA	9	11	13,5	17,5	22	24	26	30
A	22	22	26	32	40	44	56	56
B	22	22	30	36	44	50	56	56
H	3,8	3,8	4,9	5,9	7	8	8,5	8,5
T	0,5	0,5	0,7	0,8	0,9	1	1	1
VPE	100	100	100	100	100	100	50	50

Geeignet für Schraubenverbindungen bis Festigkeitsklasse 5.6.

Neigung: 8% (zwei Rillen)

Lieferbar in Stahl sowie Edelstahl A2

Werkstoff Härte: Stahl 100 HV bis 250 HV

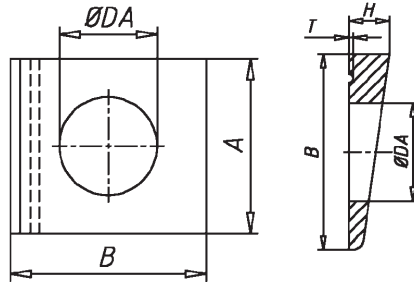

Maße in mm

DA	9	11	13,5	17,5	22	24	26	30
A	22	22	26	32	40	44	56	56
B	22	22	30	36	44	50	56	56
H	4,6	4,6	6,2	7,5	9,2	10	10,8	10,8
T	0,5	0,5	0,7	0,8	0,9	1	1	1
VPE	200	200	200	100	100	100	50	50

Geeignet für Schraubenverbindungen bis Festigkeitsklasse 5.6.

Neigung: 14 % (eine Rille)

Lieferbar in Stahl

Werkstoff Härte: Stahl 100 HV bis 250 HV





Maße in mm

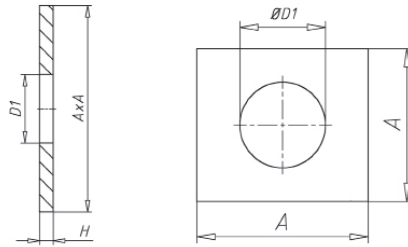

D1	11	13,5	17,5	22	26	30	33	36	39
A	30	40	50	60	80	90	95	100	110
H	3	4	5	5	6	6	6	6	8
VPE	100	100	100	100	100	50	50	50	50

Lieferbar in Stahl
Härteklasse: 100 HV

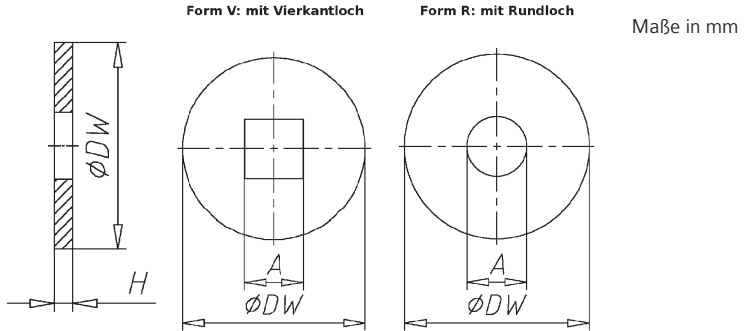

A (Nennmaß)	5,5	6,6	9	11	13,5	17,5	22
für Gewinde \emptyset	5	6	8	10	12	16	20
DW	18	22	28	34	44	56	72
H	2	2	3	3	4	5	6
VPE	1000	500	200	200	100	100	50
A (Nennmaß)	24	26	30	33	36	39	42
für Gewinde \emptyset	22	24	27	30	33	36	39
DW	80	85	98	105	112	125	140
H	6	6	6	6	6	8	8
VPE	50	25	25	25	25	25	5

Form V nur lieferbar von Nenndurchmesser 5 - 22.
 Lieferbar in Stahl sowie Edelstahl A2
 Härteklasse: 100 HV



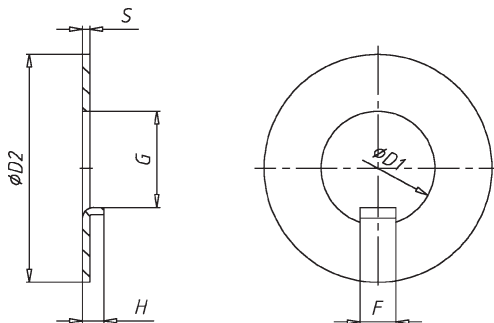

Maße in mm

D1	8	10	12	14	16	18	20	22	24		
D2	20	25	28	30	32	34	36	40	42		
S	0,8	0,8	0,8	0,8	1	1	1	1	1		
F	3	4	5	5	5	6	6	6	6		
G	5,9	7,4	9,3	11,4	13,5	15,4	17,5	19,5	21,6		
H	2,5	3	3	3	3	4	4	4	4		
VPE	200	200	200	200	200	200	200	200	200		
D1	26	28	30	32	35	38	40	42	45		
D2	45	50	50	52	55	58	62	62	68		
S	1	1	1,2	1,2	1,2	1,2	1,2	1,2	1,2		
F	7	7	7	7	7	8	8	8	8		
G	23,5	25,5	27,5	29,6	32,6	35,3	37,3	39,3	42,4		
H	5	5	5	5	5	5	5	5	5		
VPE	100	100	100	100	100	100	100	100	100		
D1	48	50	52	55	58	60	62	65	68	70	72
D2	75	75	80	80	90	90	95	95	100	100	110
S	1,2	1,2	1,2	1,2	1,5	1,5	1,5	1,5	1,5	1,5	1,5
F	8	8	10	10	10	10	10	10	10	10	10
G	45,4	47,4	49,3	52,3	55,3	57,3	59,3	62,4	65,4	67,4	68,9
H	5	5	6	6	6	6	6	6	6	6	7
VPE	50	50	50	50	50	50	50	50	50	20	20

Lieferbar in Stahl

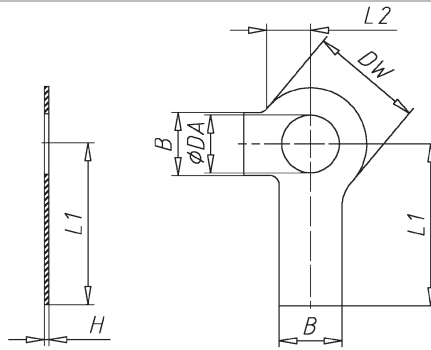

Maße in mm



DA	3,2	4,3	5,3	6,4	8,4	10,5	13	15	17		
B	4	5	6	7	8	10	12	12	15		
DW	7	9	10	12,5	17	21	24	28	30		
L1	13	14	16	18	20	22	28	28	32		
L2	5	6,5	8	9	11	13	15	16	18		
H	0,38	0,38	0,5	0,5	0,75	0,75	1	1	1		
VPE	1000	1000	1000	1000	1000	500	500	200	200		
DA	19	21	23	25	28	31	34	40	43	46	50
B	18	18	20	20	23	26	28	32	35	38	40
DW	34	37	39	44	50	56	60	72	78	85	92
L1	36	36	42	42	48	52	56	64	70	75	80
L2	20	21	23	25	29	32	34	41	44	48	50
H	1	1	1	1	1,6	1,6	1,6	1,6	1,6	1,6	1,6
VPE	200	200	100	100	100	50	50	50	50	50	25

Lieferbar in Stahl



Maße in mm

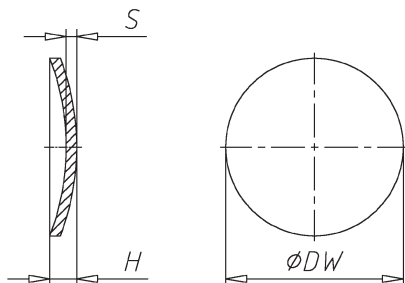

DW	H	S	VPE
5	1,35	0,8	100
6	1,67	1	100
8	1,94	1	100
10	2,67	1,6	100
12	2,77	1,6	100
14	2,94	1,6	100
16	3,11	1,6	100
18	3,28	1,6	100
20	3,45	1,6	100
22	4,09	2	100
25	4,38	2	100
28	4,53	2	100
30	4,77	2	100

DW	H	S	VPE
32	4,95	2	50
34	5,11	2	50
36	5,36	2	50
38	5,6	2	50
40	5,7	2	50
42	5,8	2	50
45	6,15	2	50
48	6,38	2	50
50	6,62	2	50
52	6,66	2	50
56	7,06	2	50
60	7,47	2	50
63	7,7	2	50

Lieferbar in Stahl

Maße in mm

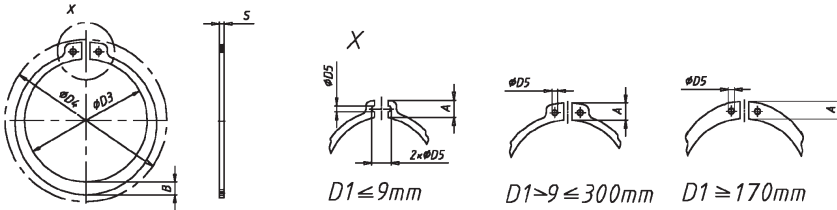

Nennmaß	D1 ¹⁾	D3	B	S	VPE
A3	3	2,7	0,8	0,4	1000
A4	4	3,7	0,9	0,4	1000
A5	5	4,7	1,1	0,6	1000
A6	6	5,6	1,3	0,7	1000
A7	7	6,5	1,4	0,8	1000
A8	8	7,4	1,5	0,8	1000
A9	9	8,4	1,7	1	1000
A10	10	9,3	1,8	1	1000
A11	11	10,2	1,8	1	1000
A12	12	11	1,8	1	1000
A13	13	11,9	2	1	1000
A14	14	12,9	2,1	1	500
A15	15	13,8	2,2	1	500
A16	16	14,7	2,2	1	500
A17	17	15,7	2,3	1	500
A18	18	16,5	2,4	1,2	500
A19	19	17,5	2,5	1,2	500
A20	20	18,5	2,6	1,2	500
A21	21	19,5	2,7	1,2	500
A22	22	20,5	2,8	1,2	500
A23	23	21,2	3	1,2	500

Nennmaß	D1 ¹⁾	D3	B	S	VPE
A24	24	22,2	3	1,2	500
A25	25	23,2	3	1,2	500
A26	26	24,2	3,1	1,2	250
A27	27	24,9	3,2	1,5	250
A28	28	25,9	3,2	1,5	250
A29	29	26,9	3,4	1,5	250
A30	30	27,9	3,5	1,5	250
A31	31	28,6	3,6	1,5	250
A32	32	29,6	3,6	1,5	250
A33	33	30,5	3,8	1,5	250
A34	34	31,5	3,8	1,5	250
A35	35	32,2	3,9	1,5	250
A36	36	33,2	4	1,75	250
A37	37	34,2	4,2	1,75	250
A38	38	35,2	4,2	1,75	250
A39	39	35,5	4,4	1,75	250
A40	40	36,5	4,4	1,75	100
A42	42	38,5	4,5	1,75	100
A44	44	40,5	4,7	1,75	100
A45	45	41,5	4,7	1,75	100
A46	46	42,5	5	1,75	100

¹⁾ ø Welle



Nennmaß	D1 ¹⁾	D3	B	S	VPE
A47	47	43,5	5	1,75	100
A48	48	44,5	5	1,75	100
A50	50	45,8	5,1	2	100
A52	52	47,8	5,2	2	100
A54	54	49,8	5,4	2	100
A55	55	50,8	5,4	2	100
A56	56	51,8	5,5	2	100
A57	57	52,8	5,6	2	100
A58	58	53,8	5,6	2	100
A60	60	55,8	5,8	2	100
A62	62	57,8	6	2	100
A63	63	58,8	6,2	2	100
A65	65	60,8	6,3	2,5	100
A67	67	62,5	6,5	2,5	100
A68	68	63,5	6,5	2,5	100
A70	70	65,5	6,6	2,5	50
A72	72	67,5	6,8	2,5	50
A75	75	70,5	7	2,5	50
A78	78	73,5	7,3	2,5	50
A80	80	74,5	7,4	2,5	50
A82	82	76,5	7,6	2,5	50
A85	85	79,5	7,8	3	50
A87	87	81,5	8	3	50
A88	88	82,5	8	3	50
A90	90	84,5	8,2	3	50

Nennmaß	D1 ¹⁾	D3	B	S	VPE
A92	92	86,5	8,2	3	50
A95	95	89,5	8,6	3	50
A97	97	91,5	8,6	3	50
A98	98	92,5	9	3	50
A100	100	94,5	9	3	25
A105	105	98	9,3	4	25
A110	110	103	9,6	4	25
A115	115	108	9,8	4	25
A120	120	113	10,2	4	25
A125	125	118	10,4	4	25
A128	128	121	10,7	4	25
A130	130	123	10,7	4	25
A135	135	128	11	4	25
A140	140	133	11,2	4	25
A145	145	138	11,5	4	25
A150	150	142	11,8	4	25
A160	160	151	12,2	4	25
A170	170	160,5	12,9	4	25
A180	180	170,5	13,5	4	25
A190	190	180,5	14	4	25
A200	200	190,5	14	4	25
A220	220	208	14	5	25
A240	240	228	14	5	25
A250	250	238	14	5	25

Die Sicherungsringe brauchen der bildlichen Darstellung nicht zu entsprechen, nur die angegebenen Maße sind einzuhalten. Ringform nach Wahl des Herstellers.

Lieferbar in Stahl sowie NIRO

¹⁾ ∅ Welle

Maße in mm

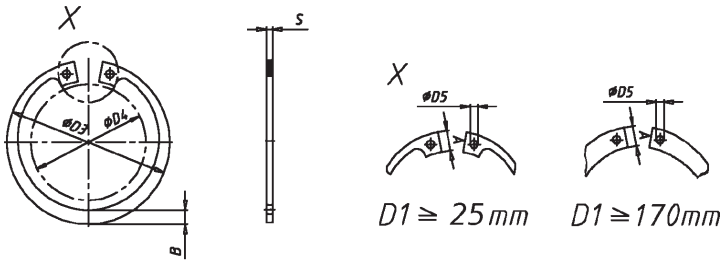

Nennmaß	D1 ¹⁾	D3	B	S	VPE
I8	8	8,7	1,1	0,8	1000
I9	9	9,8	1,3	0,8	1000
I10	10	10,8	1,4	1	1000
I11	11	11,8	1,5	1	1000
I12	12	13	1,7	1	1000
I13	13	14,1	1,8	1	500
I14	14	15,1	1,9	1	500
I15	15	16,2	2	1	500
I16	16	17,3	2	1	500
I17	17	18,3	2,1	1	500
I18	18	19,5	2,2	1	500
I19	19	20,5	2,2	1	500
I20	20	21,5	2,3	1	500
I21	21	22,5	2,4	1	500
I22	22	23,5	2,5	1	500
I23	23	24,9	2,6	1,2	500
I24	24	25,9	2,6	1,2	500
I25	25	26,9	2,7	1,2	500
I26	26	27,9	2,8	1,2	250
I27	27	29,1	2,9	1,2	250
I28	28	30,1	2,9	1,2	250

Nennmaß	D1 ¹⁾	D3	B	S	VPE
I29	29	31,1	3	1,2	250
I30	30	32,1	3	1,2	250
I31	31	33,4	3,2	1,2	250
I32	32	34,4	3,2	1,2	250
I33	33	35,5	3,3	1,5	250
I34	34	36,5	3,3	1,5	250
I35	35	37,8	3,4	1,5	250
I36	36	38,8	3,5	1,5	250
I37	37	39,8	3,6	1,5	250
I38	38	40,8	3,7	1,5	250
I39	39	42,5	3,9	1,75	250
I40	40	43,5	3,9	1,75	100
I41	41	44,5	4,1	1,75	100
I42	42	45,5	4,1	1,75	100
I43	43	46,5	4,3	1,75	100
I44	44	47,5	4,3	1,75	100
I45	45	48,5	4,3	1,75	100
I46	46	49,5	4,4	1,75	100
I47	47	50,5	4,4	1,75	100
I48	48	51,5	4,5	1,75	100
I50	50	54,2	4,6	2	100

¹⁾ Ø Bohrung





Nennmaß	D1 ¹⁾	D3	B	S	VPE
151	51	55,2	4,7	2	100
152	52	56,2	4,7	2	100
153	53	57,2	5	2	100
154	54	58,2	5	2	100
155	55	59,2	5	2	100
156	56	60,2	5,1	2	100
157	57	61,2	5,2	2	100
158	58	62,2	5,2	2	100
160	60	64,2	5,4	2	100
162	62	66,2	5,5	2	100
163	63	67,2	5,6	2	100
165	65	69,2	5,8	2,5	100
167	67	71,5	6,1	2,5	100
168	68	72,5	6,1	2,5	100
170	70	74,5	6,2	2,5	50
172	72	76,5	6,4	2,5	50
175	75	79,5	6,6	2,5	50
178	78	82,5	6,8	2,5	50
180	80	85,5	7	2,5	50
182	82	87,5	7	2,5	50
185	85	90,5	7,2	3	50
188	88	93,5	7,4	3	50
190	90	95,5	7,6	3	50
192	92	97,5	7,8	3	50
195	95	100,5	8,1	3	50
197	97	102,5	8,3	3	50
198	98	103,5	8,3	3	50
1100	100	105,5	8,4	3	50

Nennmaß	D1 ¹⁾	D3	B	S	VPE
I102	102	108	8,5	4	25
I105	105	112	8,7	4	25
I110	110	117	9	4	25
I112	112	119	9,1	4	25
I115	115	122	9,3	4	25
I120	120	127	9,7	4	25
I125	125	132	10	4	25
I130	130	137	10,2	4	25
I132x4	132	139	10,5	4	25
I140	140	147	10,7	4	25
I145	145	152	10,9	4	25
I150	150	158	11,2	4	25
I155	155	164	11,4	4	25
I160	160	169	11,6	4	25
I165	165	174,5	11,8	4	25
I170	170	179,5	12,2	4	25
I175	175	184,5	12,7	4	25
I180	180	189,5	13,2	4	25
I190	190	199,5	13,8	4	25
I200	200	209,5	14	4	25
I210	210	222	14	5	25
I215	215	227	14	5	25
I220	220	232	14	5	25
I225	225	237	14	5	25
I230	230	242	14	5	25
I240	240	252	14	5	25
I250	250	262	14	5	25

Die Sicherungsringe brauchen der bildlichen Darstellung nicht zu entsprechen, nur die angegebenen Maße sind einzuhalten.
Ringform nach Wahl des Herstellers.

Lieferbar in Stahl sowie NIRO

¹⁾ Ø Bohrung

Maße in mm

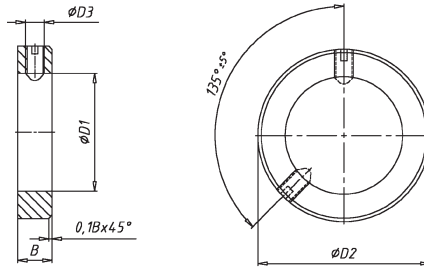

D1	D2	D3	B	GS ¹⁾	VPE
3	7	M2	5	M2x3	200
4	8	M2,5	5	M2,5x3	200
5	10	M3	6	M3x4	100
6	12	M4	8	M4x5	100
7	12	M4	8	M4x5	100
8	16	M4	8	M4x6	100
10	20	M5	10	M5x8	100
12	22	M6	12	M6x8	100
14	25	M6	12	M6x8	100
15	25	M6	12	M6x8	100
16	28	M6	12	M6x8	100
18	32	M6	14	M6x8	100
20	32	M6	14	M6x8	50
22	36	M6	14	M6x10	50
24	40	M8	16	M8x12	50
25	40	M8	16	M8x10	25
26	40	M8	16	M8x10	25
28	45	M8	16	M8x12	25

D1	D2	D3	B	GS ¹⁾	VPE
30	45	M8	16	M8x10	25
32	50	M8	16	M8x12	10
35	56	M8	16	M8x12	10
36	56	M8	16	M8x12	10
40	63	M10	18	M10x16	10
45	70	M10	18	M10x16	10
50	80	M10	18	M10x16	10
55	80	M10	18	M10x16	10
60	90	M10	20	M10x16	10
63	90	M10	20	M10x16	10
65	100	M10	20	M10x20	10
70	100	M10	20	M10x20	10
75	110	M12	22	M12x20	10
80	110	M12	22	M12x20	5
90	125	M12	22	M12x20	5
100	140	M12	25	M12x25	5
110	160	M12	25	M12x30	5
120	160	M12	25	M12x25	5

Bis \varnothing 70 mit 1 Gewindestift.

Über \varnothing 70 mit 2 Gewindestiften.

Lieferbar in Stahl sowie Edelstahl A2

¹⁾ Gewindestift nach DIN 553 (Weitere Gewindestiftausführungen auf Anfrage lieferbar.)

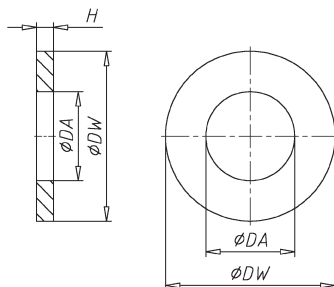

Maße in mm

Nennmaß ¹⁾	VPE	Nennmaß ¹⁾	VPE
SS3x6x1	1000	SS26x37x2	250
SS4x8x1	1000	SS28x40x2	250
SS5x10x1	1000	SS30x42x2,5	200
SS6x12x1,2	1000	SS32x45x2,5	200
SS7x13x1,2	1000	SS35x45x2,5	200
SS8x14x1,2	1000	SS36x45x2,5	200
SS9x15x1,2	1000	SS37x47x2,5	200
SS10x16x1,2	500	SS40x50x2,5	100
SS11x17x1,2	500	SS42x52x2,5	100
SS12x18x1,2	500	SS45x55x3	100
SS13x19x1,5	500	SS45x56x3	100
SS14x20x1,5	500	SS48x60x3	100
SS15x21x1,5	500	SS50x62x3	100
SS16x22x1,5	500	SS50x63x3	100
SS17x24x1,5	500	SS52x65x3	100
SS18x25x1,5	500	SS55x68x3	100
SS19x26x1,5	500	SS56x70x2	100
SS20x28x2	250	SS56x72x3	100
SS22x30x2	250	SS60x75x3	100
SS22x32x2	250	SS63x80x3	100
SS25x35x2	250	SS65x85x3,5	100
SS25x36x2	250	SS70x90x3,5	100

¹⁾ DA x DW x H

Nennmaß ¹⁾	VPE
SS75x95x3,5	100
SS80x100x3,5	100
SS85x105x0,3	100

Nennmaß ¹⁾	VPE
SS90x110x3,5	100
SS95x115x1	100
SS100x120x3,5	50

Lieferbar in Stahl

Werkstoff: Federstahl, Härte 400 - 500 HV

¹⁾ DA x DW x H

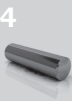

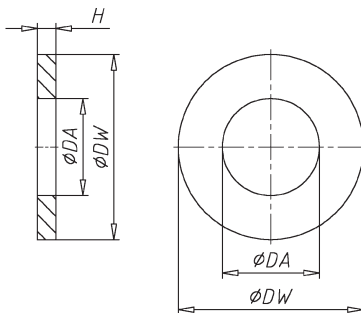

Maße in mm

VPE

DA X DW X	0,1	0,2	0,3	0,5	1	1,5	2
3x6	1000	1000	1000	1000	1000	–	–
4x8	1000	1000	1000	1000	1000	–	–
5x10	1000	1000	1000	1000	1000	–	–
6x12	1000	1000	1000	1000	1000	–	–
7x13	1000	1000	1000	1000	1000	–	–
8x14	1000	1000	1000	1000	1000	1000	–
9x15	1000	1000	1000	1000	1000	500	–
10x16	500	500	500	500	500	500	500
11x17	500	500	500	500	500	500	500
12x18	500	500	500	500	500	500	500
13x19	500	500	500	500	500	500	500
14x20	500	500	500	500	500	500	500
15x21	500	500	500	500	500	500	500
15x22	500	500	500	500	500	500	500
16x22	500	500	500	500	500	500	500
17x24	500	500	500	500	500	500	500
18x25	500	500	500	500	500	500	500
19x26	500	500	500	500	500	500	500
20x28	250	250	250	250	250	250	250
22x30	250	250	250	250	250	250	250
22x32	250	250	250	250	250	250	250
25x35	250	250	250	250	250	250	250
25x36	250	250	250	250	250	250	250
26x37	250	250	250	250	250	250	250
28x40	250	250	250	250	250	250	250
30x42	200	200	200	200	200	200	200
32x45	200	200	200	200	200	200	200

DA X DW X	0,1	0,2	0,3	0,5	1	1,5	2
35x45	200	200	200	200	200	200	200
36x45	200	200	200	200	200	200	200
37x47	200	200	200	200	200	200	200
40x50	100	100	100	100	100	100	100
42x52	100	100	100	100	100	100	100
45x55	100	100	100	100	100	100	100
48x60	100	100	100	100	100	100	100
50x62	100	100	100	100	100	100	100
50x63	100	100	100	100	100	100	100
52x65	100	100	100	100	100	100	100
55x68	100	100	100	100	100	100	100
56x70	100	100	100	100	100	100	100
56x72	100	100	100	100	100	100	100
60x75	100	100	100	100	100	100	100
63x80	100	100	100	100	100	100	100
65x85	100	100	100	100	100	100	100
70x90	100	100	100	100	100	100	100
75x95	100	100	100	100	100	100	100
80x100	100	100	100	100	100	100	100
85x105	100	100	100	100	100	100	100
90x110	100	100	100	100	100	100	100
100x120	50	50	50	50	50	50	50
100x125	50	50	50	50	50	–	–
110x140	50	50	50	50	50	–	–
120x150	50	50	50	50	50	–	–
130x160	50	50	50	50	50	–	–
140x170	50	50	50	50	50	–	–
150x180	50	50	50	50	25	–	–
160x190	50	50	50	50	25	–	–
170x200	50	50	50	50	25	–	–

Die handelsüblichen Größen sind durch Angabe der VPE gekennzeichnet.
Lieferbar in Stahl (Mindestgüte St K 50)



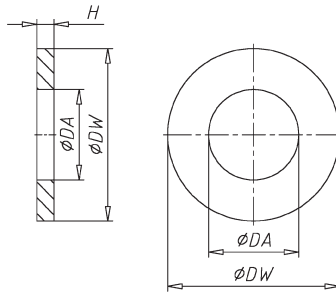

Maße in mm

DA	14	18	23	25	27
DW	58	68	80	92	105
H	6	6	8	8	8
VPE	50	50	25	25	25

Lieferbar in Stahl sowie Edelstahl A2

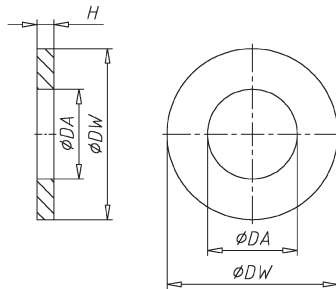

Maße in mm

DA	3	4	5	6	7	8	10	12					
DW	6	8	10	12	14	16	20	25					
H	0,8	0,8	0,8	1,6	1,6	2	2,5	3					
VPE	1000	1000	1000	1000	1000	1000	500	500					
DA	13	14	16	18	20	22	23	24	25	26			
DW	25	28	28	30	32	34	36	38	40	40			
H	3	3	3	4	4	4	4	4	4	5			
VPE	500	500	250	250	250	250	250	250	100	100			
DA	28	30	32	33	35	36	40	45	50	55	60	65	70
DW	42	45	50	50	52	52	58	62	68	75	80	90	95
H	5	5	5	5	6	6	6	7	8	9	9	9	10
VPE	50	50	50	50	50	50	50	50	50	25	25	25	25

Lieferbar in Stahl sowie Edelstahl A2 und Edelstahl A4

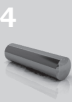

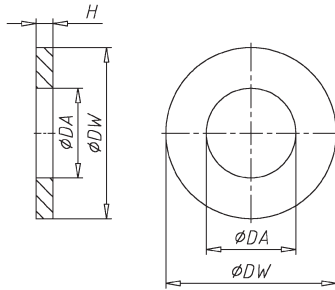

Maße in mm

DA	5,5	7	8	9	11	13	14	15	17	19	21			
DW	10	12	14	16	20	25	25	28	28	30	32			
H	0,8	1,6	1,6	2	2,5	3	3	3	3	4	4			
VPE	1000	1000	1000	1000	500	500	500	500	250	250	250			
DA	23	24	25	26	27	28	29	31	34	37	41	46	51	56
DW	34	36	38	40	40	40	42	45	50	52	58	62	68	75
H	4	4	4	4	5	5	5	5	5	6	6	7	8	9
VPE	200	100	100	100	50	50	50	50	50	50	50	50	50	25





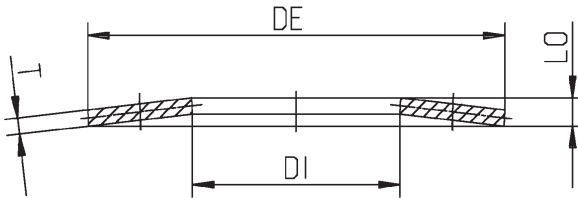



Lieferbar in Stahl sowie Edelstahl A2

Maße in mm



Nennmaß ¹⁾	LO	REIHE	VPE	Nennmaß ¹⁾	LO	REIHE	VPE
8X3,2X0,3	0,55		500	14X7,2X0,35	0,8	C	500
8X3,2X0,4	0,6		500	14X7,2X0,5	0,9	B	500
8X3,2X0,5	0,7		500	14X7,2X0,8	1,1	A	500
8X4,2X0,2	0,45	C	500	15X5,2X0,4	0,95		500
8X4,2X0,3	0,55	B	500	15X5,2X0,5	1		500
8X4,2X0,4	0,6	A	500	15X5,2X0,6	1,05		500
10X3,2X0,3	0,65		500	15X5,2X0,7	1,10		500
10X3,2X0,5	0,75		500	15X6,2X0,5	1		500
10X4,2X0,4	0,7		500	15X6,2X0,7	1,1		500
10X4,2X0,5	0,75		500	15X8,2X0,7	1,1		500
10X5,2X0,25	0,55	C	500	15X8,2X0,8	1,2		500
10X5,2X0,4	0,7	B	500	16X8,2X0,4	0,9	C	500
10X5,2X0,5	0,75	A	500	16X8,2X0,6	1,05	B	500
12X4,2X0,4	0,8		500	16X8,2X0,9	1,25	A	500
12X4,2X0,5	0,85		500	18X6,2X0,5	1,1		500
12X4,2X0,6	1		500	18X6,2X0,6	1,2		500
12X5,2X0,5	0,9		500	18X6,2X0,7	1,25		500
12X5,2X0,6	0,95		500	18X6,2X0,8	1,3		500
12X6,2X0,5	0,85		500	18X8,2X0,7	1,25		500
12X6,2X0,6	0,95		500	18X8,2X0,8	1,3		500
12,5X6,2X0,35	0,8	C	500	18X8,2X1	1,4		500
12,5X6,2X0,5	0,85	B	500	18X9,2X0,45	1,05	C	500
12,5X6,2X0,7	1	A	500	18X9,2X0,7	1,2	B	500

¹⁾ Nennmaß = DE X DI X T

	Nennmaß ¹⁾	LO	REIHE	VPE	Nennmaß ¹⁾	LO	REIHE	VPE
	18X9,2X1	1,4	A	500	28X14,2X1,25	2,1		250
	20X8,2X0,6	1,3		250	28X14,2X1,5	2,15	A	250
	20X8,2X0,7	1,35		250	31,5X16,3X0,8	1,85	C	200
	20X8,2X0,8	1,4		250	31,5X16,3X1,25	2,15	B	200
	20X8,2X0,9	1,45		250	31,5X16,3X1,5	2,4		200
	20X8,2X1	1,55		250	31,5X16,3X1,75	2,45	A	200
	20X10,2X0,5	1,15	C	250	31,5X16,3X2	2,75		200
	20X10,2X0,8	1,35	B	250	34X12,2X1	2,25		200
	20X10,2X0,9	1,45		250	34X12,2X1,25	2,35		200
	20X10,2X1	1,55		250	34X12,2X1,5	2,5		200
	20X10,2X1,1	1,55	A	250	34X16,3X1,5	2,55		200
	22,5X11,2X0,6	1,4	C	250	34X16,3X2	2,85		200
	22,5X11,2X0,8	1,45	B	250	35,5X18,3X0,9	2,05	C	200
	22,5X11,2X1,25	1,75	A	250	35,5X18,3X1,25	2,25	B	200
	23X8,2X0,7	1,5		250	35,5X18,3X2	2,8	A	200
	23X8,2X0,8	1,55		250	40X14,3X2	3,05		200
	23X8,2X0,9	1,6		250	40X16,3X1,5	2,8		200
	23X10,2X0,9	1,65		250	40X16,3X2	3,1		200
	23X10,2X1	1,7		250	40X18,3X2	3,15		200
	23X10,2X1,25	1,6		250	40X20,4X1	2,3	C	200
	23X12,2X1,25	1,85		250	40X20,4X1,5	2,65	B	200
	23X12,2X1,5	2		250	40X20,4X2	3,1		200
	25X12,2X0,7	1,6	C	250	40X20,4X2,25	3,15	A	200
	25X12,2X0,9	1,6	B	250	40X20,4X2,5	3,45		200
	25X12,2X1,5	2,05	A	250	45X22,4X1,25	2,85	C	200
	28X10,2X0,8	1,75		250	45X22,4X1,75	3,05	B	200
	28X10,2X1	1,9		250	45X22,4X2,5	3,5	A	200
	28X10,2X1,25	2,05		250	50X20,4X2	3,5		100
	28X12,2X1	1,95		250	50X20,4X2,5	3,85		100
	28X12,2X1,25	2,1		250	50X22,4X2	3,6		100
	28X12,2X1,5	2,25		250	50X22,4X2,5	3,9		100
	28X14,2X0,8	1,8	C	250	50X25,4X1,25	2,85	C	100
	28X14,2X1	1,8	B	250	50X25,4X1,5	3,1		100

¹⁾ Nennmaß = DE X DI X T

Nennmaß ¹⁾	LO	REIHE	VPE	Nennmaß ¹⁾	LO	REIHE	VPE
50X25,4X2	3,4	B	100	71X36X4	5,6	A	50
50X25,4X2,5	3,9		100	80X36X3	5,7		50
50X25,4X3	4,1	A	100	80X41X2,25	5,2	C	50
56X28,5X1,5	3,45	C	100	80X41X3	5,3	B	50
56X28,5X2	3,6	B	100	80X41X4	6,2		50
56X28,5X3	4,3	A	100	80X41X5	6,7	A	50
60X20,5X2	4,1		50	90X46X2,5	5,7	C	50
60X20,5X3	4,7		50	90X46X3,5	6	B	50
60X25,5X2,5	4,4		50	90X46X5	7	A	50
60X25,5X3	4,65		50	100X51X2,7	6,2	C	25
60X30,5X2,5	4,3		50	100X51X3,5	6,3	B	25
60X30,5X3	4,7		50	100X51X4	7		25
60X30,5X3,5	5		50	100X51X6	8,2	A	25
63X31X1,8	4,15	C	50	112X57X3	6,9	C	25
63X31X2,5	4,25	B	50	112X57X4	7,2	B	25
63X31X3	4,8		50	112X57X6	8,5	A	25
63X31X3,5	4,9	A	50	125X64X3,5	8	C	25
70X25,5X2	4,5		50	125X64X5	8,5	B	25
70X30,5X2,5	4,9		50	125X64X8	10,8	A	10
70X30,5X3	5,1		50	140X72X3,8	8,7	C	25
70X35,5X3	5,1		50	140X72X5	9	B	25
70X35,5X4	5,8		50	140X72X8	11,2	A	25
70X40,5X4	5,6		50	160X82X4,3	9,9	C	10
70X40,5X5	6,2		50	160X82X6	10,5	B	10
71X36X2	4,6	C	50	160X82X10	13,5	A	10
71X36X2,5	4,5	B	50				

¹⁾ Nennmaß = DE X DI X T

Tellerfedern sind kegelförmig ausgebildete Ringschalen, die in Achsrichtung belastet werden. Sie können sowohl ruhend, selten schwingend als auch durch dynamische Dauerbelastung beansprucht werden. Zur Erzielung bestimmter Kennlinien und Federwege werden die Einzelteller zu Federpaketen und Federsäulen kombiniert. Tellerfedern sind genormt nach DIN 2092 (Berechnung) und DIN 2093 (Maße und Qualitätsforderungen).





Maße in mm

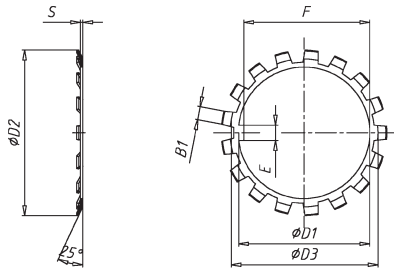

Nennmaß	D1	D2	D3	B1	E	F	S	VPE
MB 0	10	21	13,5	3	3	8,5	1	50
MB 1	12	25	17	3	3	10,5	1	50
MB 2	15	28	21	4	4	13,5	1	50
MB 3	17	32	24	4	4	15,5	1	50
MB 4	20	36	26	4	4	18,5	1	50
MB 5	25	42	32	5	5	23	1,25	50
MB 6	30	49	38	5	5	27,5	1,25	50
MB 7	35	57	44	5	6	32,5	1,25	50
MB 8	40	62	50	6	6	37,5	1,25	50
MB 9	45	69	56	6	6	42,5	1,25	50
MB 10	50	74	61	6	6	47,5	1,25	50
MB 11	55	81	67	7	8	52,5	1,5	50
MB 12	60	86	73	7	8	57,5	1,5	50
MB 13	65	92	79	7	8	62,5	1,5	25
MB 14	70	98	85	8	8	66,5	1,5	25
MB 15	75	104	90	8	8	71,5	1,5	25
MB 16	80	112	95	8	10	76,5	1,75	25
MB 17	85	119	102	8	10	81,5	1,75	25
MB 18	90	126	108	10	10	86,5	1,75	25
MB 19	95	133	113	10	10	91,5	1,75	25
MB 20	100	142	120	10	12	96,5	1,75	10
MB 21	105	145	126	12	12	100,5	1,75	10
MB 22	110	154	133	12	12	105,5	1,75	10

Nennmaß	D1	D2	D3	B1	E	F	S	VPE
MB 23	115	159	137	12	12	110,5	2	10
MB 24	120	164	138	12	14	115	2	10
MB 25	125	170	148	12	14	120	2	10
MB 26	130	175	149	12	14	125	2	10
MB 27	135	185	160	14	14	130	2	10
MB 28	140	192	160	14	16	135	2	10
MB 29	145	202	171	14	16	140	2	10
MB 30	150	205	171	14	16	145	2	1

Lieferbar in Stahl (min 300 N/mm² Zugfestigkeit)



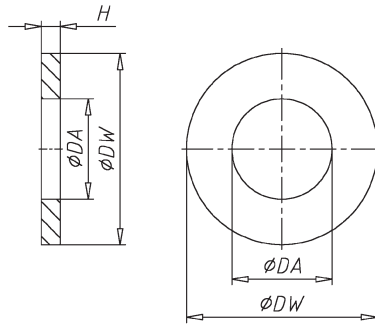

Maße in mm

DA	6,4	8,4	10,5	13	17	21	25	31
DW	17	23	28	35	45	50	60	68
H	3	4	4	5	6	6	8	10
VPE	500	200	200	100	100	100	100	100

Ausführung: Vergütet, Härte (350+80) HV 30
Lieferbar in Stahl

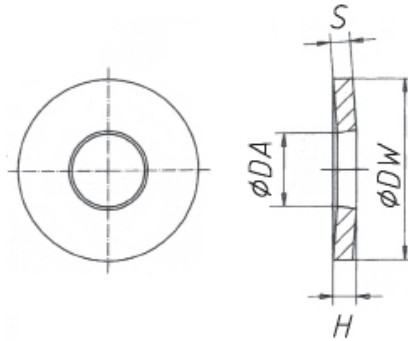

Maße in mm

Nennmaß	2	2,5	3	3,5	4	5	6
DA	2,2	2,7	3,2	3,7	4,3	5,3	6,4
DW	5	6	7	8	9	11	14
H	0,6	0,72	0,85	1,06	1,3	1,55	2
S	0,4	0,5	0,6	0,8	1	1,2	1,5
VPE	1000	1000	1000	1000	1000	1000	1000

Nennmaß	8	10	12	14	16	18	20	22	24
DA	8,4	10,5	13	15	17	19	21	23	25
DW	18	23	29	35	39	42	45	49	56
H	2,6	3,2	3,95	4,65	5,25	5,8	6,4	7,05	7,75
S	2	2,5	3	3,5	4	4,5	5	5,5	6
VPE	1000	500	500	500	100	100	100	100	100

Lieferbar in Stahl sowie NIRO





Maße in mm

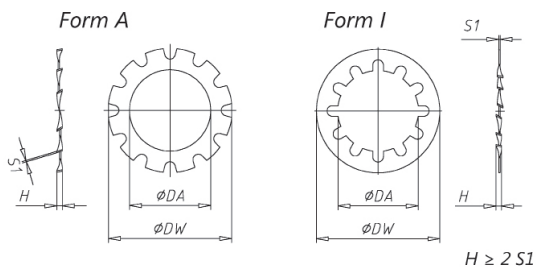

Nennmaß	DA	DW	S1	VPE
A2	2,2	4,5	0,3	1000
A2,5	2,7	5,5	0,4	1000
A3	3,2	6	0,4	1000
A3,5	3,7	7	0,5	1000
A4	4,3	8	0,5	1000
A5	5,3	10	0,6	1000
A6	6,4	11	0,7	1000
A8	8,4	15	0,8	1000
A10	10,5	18	0,9	500
A12	13	20,5	1	500
A14	15	24	1	500
A16	17	26	1,2	250
A18	19	30	1,4	250
A20	21	33	1,4	100
A24	25	38	1,5	100

Nennmaß	DA	DW	S1	VPE
J2	2,2	4,5	0,3	1000
J2,5	2,6	5,5	0,4	1000
J3	3,2	6	0,4	1000
J3,5	3,7	7	0,5	1000
J4	4,3	8	0,5	1000
J5	5,3	10	0,6	1000
J6	6,4	11	0,7	1000
J8	8,4	15	0,8	1000
J10	10,5	18	0,9	500
J12	13	20,5	1	500
J14	15	24	1	500
J16	17	26	1,2	200
J18	19	30	1,4	200
J20	21	33	1,4	200
J24	25	38	1,5	100

Lieferbar in Stahl sowie NIRO

Maße in mm

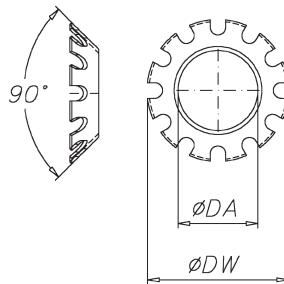

Nennmaß	DA	DW	VPE
V3	3,2	6	1000
V3,5	3,7	7	1000
V4	4,3	8	1000
V5	5,3	9,8	1000
V6	6,4	11,8	1000
V8	8,4	15,3	1000
V10	10,5	19	500
V12	13	23	250

Lieferbar in Stahl sowie NIRO





Maße in mm

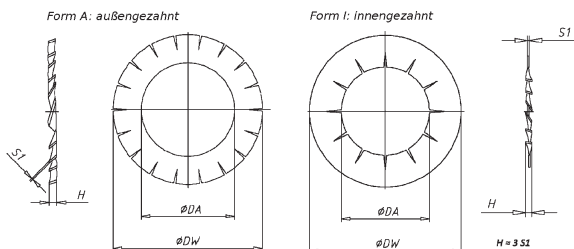

Nennmaß	DA	DW	S1	VPE
A2	2,2	4,5	0,3	1000
A2,5	2,7	5,5	0,4	1000
A3	3,2	6	0,4	1000
A3,5	3,7	7	0,5	1000
A4	4,3	8	0,5	1000
A5	5,3	10	0,6	1000
A6	6,4	11	0,7	1000
A8	8,4	15	0,8	1000
A10	10,5	16	0,9	500
A12	13	20,5	1	500
A14	15	24	1	500
A16	17	26	1,2	200
A20	21	33	1,4	200
A24	25	38	1,5	100

Nennmaß	DA	DW	S1	VPE
J2	2,2	4,5	0,3	1000
J2,5	2,6	5,5	0,4	1000
J3	3,2	6	0,4	1000
J3,5	3,7	7	0,5	1000
J4	4,3	8	0,5	1000
J5	5,3	10	0,6	1000
J6	6,4	11	0,7	1000
J8	8,4	15	0,8	1000
J10	10,5	18	0,9	500
J12	13	20,5	1	500
J14	15	24	1	500
J16	17	26	1,2	250
J20	21	33	1,4	200
J24	25	38	1,5	100

Lieferbar in Stahl sowie NIRO

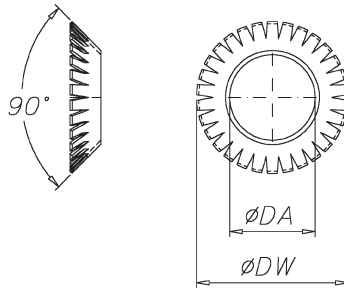

Maße in mm

Nennmaß	DA	DW	VPE
V3	3,2	6	1000
V4	4,3	8	1000
V5	5,3	9,8	1000
V6	6,4	11,8	1000
V8	8,4	15,3	1000
V10	10,5	19	500
V12	13	23	250
V16	17	30,2	200

Lieferbar in Stahl sowie NIRO





ungespannt

gespannt

Maße in mm

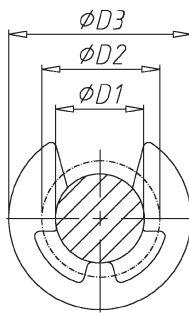
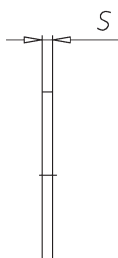
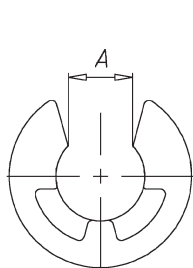

D1 ¹⁾	0,8	1,2	1,5	1,9	2,3	3,2	4	5	6
D2 ²⁾	1 - 1,4	1,4 - 2	2 - 2,5	2,5 - 3	3 - 4	4 - 5	5 - 7	6 - 8	7 - 9
D3 max	2,25	3,25	4,25	4,8	6,3	7,3	9,3	11,3	12,3
A	0,58	1,01	1,28	1,61	1,94	2,70	3,34	4,11	5,26
S	0,2	0,3	0,4	0,5	0,6	0,6	0,7	0,7	0,7
VPE	1000	1000	1000	1000	1000	1000	1000	500	500
D1 ¹⁾	7	8	9	10	12	15	19	24	30
D2 ²⁾	8 - 11	9 - 12	10 - 14	11 - 15	13 - 18	16 - 24	20 - 31	25 - 38	32 - 42
D3 max	14,3	16,3	18,8	20,4	23,4	29,4	37,6	44,6	52,6
A	5,84	6,52	7,63	8,32	10,45	12,61	15,92	21,88	25,80
S	0,9	1	1,1	1,2	1,3	1,5	1,75	2	2,5
VPE	500	500	200	200	200	200	100	100	100

¹⁾ Nut-Ø (h11)

²⁾ Wellendurchmesserbereich

Auch magaziniert lieferbar.

Lieferbar in Stahl sowie NIRO

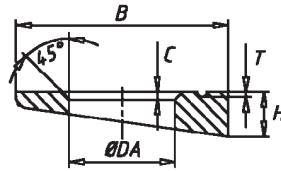
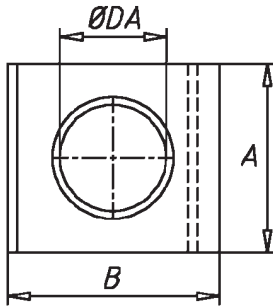

Maße in mm

DA	13	17	21	23	25	28
A	26	32	40	44	56	56
B	30	36	44	50	56	56
H	6,2	7,5	9,2	10	10,8	10,8
T	0,7	0,8	0,9	1	1	1
VPE	200	100	100	50	50	50

Scheiben sind auf der Unterseite mit dem Herstellerzeichen und mit dem Kennzeichen „HV“ versehen.
 Werkstoff Stahl (295 bis 350 HV) z.B. C45
 Neigung: 14% (eine Rille)
 Lieferbar in Güte: C45



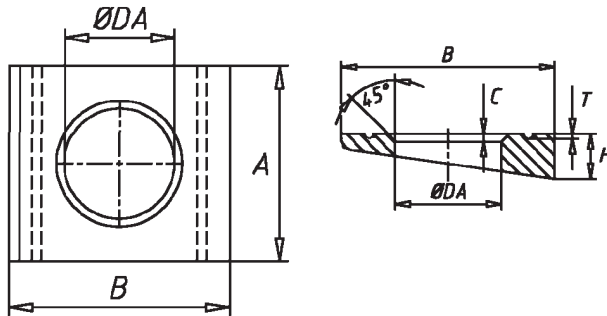

Maße in mm

DA	13	17	21	23	25	28	31	37
A	26	32	40	44	56	56	62	68
B	30	36	44	50	56	56	62	68
H	4,9	5,9	7	8	8,5	8,5	9	9,4
T	0,7	0,8	0,9	1	1	1	1	1
VPE	200	100	100	50	50	50	50	50

Scheiben sind auf der Unterseite mit dem Herstellerzeichen und mit dem Kennzeichen „HV“ versehen.
 Werkstoff Stahl (295 bis 350 HV) z.B. C45
 Neigung: 8% (zwei Rillen)
 Neigung: 5% (ohne Rille, Form Buchstabe A in der Bezeichnung)
 Lieferbar in Güte: C45

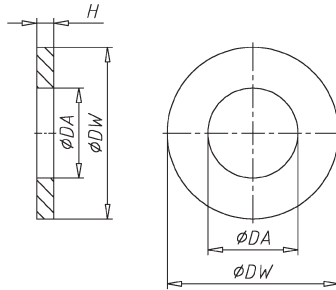

Maße in mm

DA	3,2	4,3	5,3	6,4	8,4	10,5	13
DW	9	12	15	17	21	25	30
H	1	1,6	2	3	4	4	6
SPH ¹⁾	6	8	10	12	16	18	21
VPE	1000	1000	1000	1000	500	200	100

DA	15	17	19	21	23	25	28	31
DW	36	40	44	44	50	50	60	68
H	6	6	8	8	8	10	10	10
SPH ¹⁾	25	28	32	35	38	40	45	50
VPE	100	100	50	50	50	50	50	25

Stand: Juli 1974

Werkstoff: mindestens 100 HV

Lieferbar in Stahl sowie Edelstahl A2

¹⁾ für Spannhülse nach ISO 8752





Maße in mm

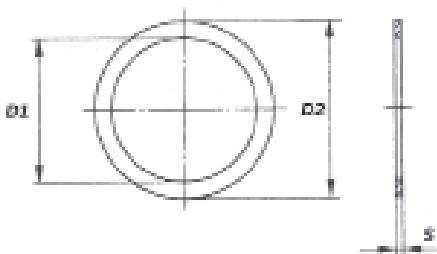

Nennmaß ¹⁾	für Verschluss- schrauben	VPE	Nennmaß ¹⁾	für Verschluss- schrauben	VPE
A4x8x1		50	A10x13,5x1,5		50
A5x9x1		50	A10x14x1	R1/8, M10X1	50
A5x9x1,5		100	A10x14x1,5		50
A5,5x8x1		50	A10x15x1		50
A6x10x1		50	A10x15x1,5		50
A6x10x1,5		100	A10x15x2		50
A6x12x1		100	A10x16x1		50
A6,3x9x1		100	A10x16x1,5		50
A6,5x9,5x1		50	A10x16x2		50
A6,5x9,5x1,5		50	A11x17x1,5		50
A8x11,5x1	M8X1	50	A11x17x2		50
A8x12x1	M8X1	50	A12x15,5x1,5	M12X1,5	50
A8x12x1,5		50	A12x16x1		50
A8x13x1		50	A12x16x1,5	M12X1,5	50
A8x14x1	M8X1	50	A12x18x1		50
A8x14x1,5		50	A12x18x1,5		50
A8x18x1		50	A12x18x2		50
A8x18x1,5		50	A12x20x1,5		50
A9x14x1,5		50	A13x18x1		50
A10x13,5x1	R1/8, M10X1	50	A13x18x1,5		50

¹⁾ D1 x D2 x S

Nennmaß ¹⁾	für Verschluss- schrauben	VPE	Nennmaß ¹⁾	für Verschluss- schrauben	VPE
A13x18x2		50	A20x24x1,5	M20X1,5	50
A13x19x1		50	A20x26x1,5	M20X1,5	50
A13x19x1,5		50	A21x26x1		50
A14x18x1		50	A21x26x1,5	R1/2	50
A14x18x1,5	R1/4, M14X1,5	50	A21x26x2		50
A14x18x1,8		50	A21x27x1,5		50
A14x18x2		50	A21x28x1,5	R1/2	50
A14x20x1		50	A22x26x1,5		50
A14x20x1,5	R1/4, M14X1,5	50	A22x27x1		50
A14x20x2		50	A22x27x1,5	M22x1,5	50
A14x22x1,5		50	A22x27x2		50
A14x22x2		50	A22x28x1,5		50
A16x20x1		50	A22x29x1,5		50
A16x20x1,5	M16X1,5	50	A23x28x1,5		50
A16x20x2		50	A23x28x2	R5/8	50
A16x22x1,5		50	A24x29x2	M24X1,5	50
A16x24x1,5		50	A24x30x2		50
A16x24x2		50	A24x32x2		50
A17x21x1,5	R3/8	50	A26x32x1,5		50
A17x21x2		50	A26x32x2		50
A17x22x1,5		50	A26x34x2		50
A17x22x2		50	A27x32x1,5		50
A17x23x1,5	R3/8	50	A27x32x2	R3/4, M27X2	50
A18x22x1		50	A28x34x2		50
A18x22x1,5	M18X1,5	50	A28x36x2		50
A18x22x2		50	A30x36x2	R7/8, M30X1,5	50
A18x24x1		50	A30x38x2		50
A18x24x1,5	M18X1,5	50	A32x38x2		50
A18x24x2		50	A33x39x2	R1, M33X2	50
A20x24x1		50	A34x40x2		50



¹⁾ D1 x D2 x S



1



2



3



4



5



6



7



8



9

Nennmaß ¹⁾	für Verschluss- schrauben	VPE	Nennmaß ¹⁾	für Verschluss- schrauben	VPE
A35x41x2		50	A45x52x2		50
A36x42x2		50	A48x55x2		50
A38x44x2	R1 1/8, M38X1,5	50	A52x60x2,5		50
A42x49x2	R1 1/4, M42X1,5	50	A60x68x2,5		50

Massiver Dichtring mit rechteckigem Querschnitt für normale Dichtprobleme. Weitere Formen auf Anfrage lieferbar. Lieferbar in Kupfer sowie Aluminium

¹⁾ D1 x D2 x S

Maße in mm

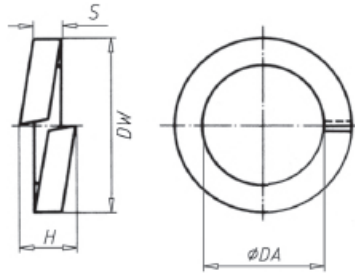

D ¹⁾	M3	M4	M5	M6	M8	M10	M12	M14
DA	3,1	4,1	5,1	6,1	8,1	10,2	12,2	14,2
DW	5,6	7	8,8	9,9	12,7	16	18	21,1
H	2	2,4	3,2	3,2	4	5	5	6
S	1	1,2	1,6	1,6	2	2,5	2,5	3
VPE	1000	1000	1000	1000	1000	1000	500	500

D ¹⁾	M16	M18	M20	M22	M24	M27	M30	M33	M36
DA	16,2	18,2	20,2	22,5	24,5	27,5	30,5	33,5	36,5
DW	24,4	26,4	30,6	32,9	35,9	38,9	44,1	47,1	52,2
H	7	7	9	9	10	10	12	12	14
S	3,5	3,5	4,5	4,5	5	5	6	6	7
VPE	250	250	100	100	100	100	50	50	50

Lieferbar in Stahl sowie NIRO

¹⁾ für Gewinde





Maße in mm

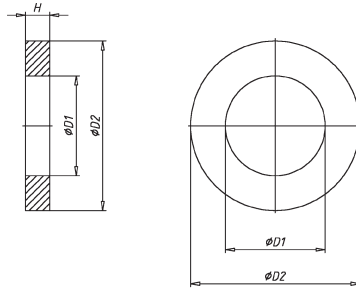

D1	11	13,5	17,5	22	26	30	33
D2	21	24	30	37	44	50	56
H	8	8	8	8	8	8	8
VPE	100	100	100	100	50	50	50

Lieferbar in Stahl sowie Edelstahl A2

Form A: für Wellen

Maße in mm

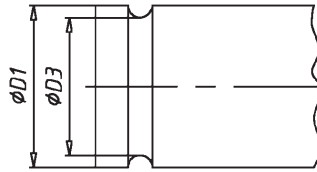
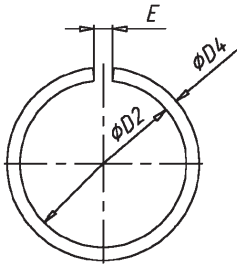

Nennmaß	D1	D2	D3	D4	E	VPE
A5	5	4,1	4,2	0,8	1	5000
A6	6	5,1	5,2	0,8	1	5000
A7	7	6,1	6,2	0,8	2	2500
A8	8	7,1	7,2	0,8	2	2500
A10	10	9,1	9,2	0,8	2	2000
A12	12	10,8	11	1	3	2000
A14	14	12,8	13	1	3	1000
A16	16	14,2	14,4	1,6	3	1000
A18	18	16,2	16,4	1,6	3	1000
A20	20	17,7	18	2	3	1000
A22	22	19,7	20	2	3	500
A25	25	22,7	23	2	3	500
A26	26	23,7	24	2	3	500
A28	28	25,7	26	2	3	500
A30	30	27,7	28	2	3	500
A32	32	29,1	29,5	2,5	4	250
A35	35	32,1	32,5	2,5	4	250
A40	40	37,1	37,5	2,5	4	250
A50	50	47	47,5	2,5	4	200
A55	55	51,1	51,8	3,2	4	200
A60	60	56,1	56,8	3,2	4	200
A65	65	61,1	61,8	3,2	4	200
A70	70	66	66,8	3,2	5	200



Nennmaß	D1	D2	D3	D4	E	VPE
A75	75	71	71,8	3,2	5	200
A80	80	76	76,8	3,2	5	200
A85	85	81	81,8	3,2	5	100
A90	90	86	86,8	3,2	5	100
A95	95	91	91,8	3,2	5	50
A100	100	95,8	96,8	3,2	5	50

Lieferbar in Stahl

Form B: für Bohrungen

Maße in mm

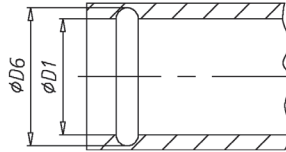
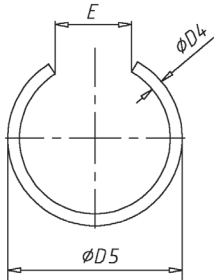

Nennmaß	D1	D4	D5	D6	E	VPE
B8	8	0,8	8,9	8,8	4	2500
B10	10	0,8	10,9	10,8	4	2000
B12	12	1	13,2	13	6	2000
B14	14	1	15,2	15	6	2000
B16	16	1,6	17,8	17,6	8	1000
B18	18	1,6	19,8	19,6	8	1000
B20	20	2	22,3	22	10	1000
B22	22	2	24,3	24	10	500
B24	24	2	26,3	26	10	500
B25	25	2	27,3	27	10	500
B26	28	2	30,3	30	10	500
B30	30	2	32,3	32	10	500
B32	32	2,5	34,9	34,5	12	250
B35	35	2,5	37,9	37,5	12	250
B38	38	2,5	40,9	40,5	12	250
B40	40	2,5	42,9	42,5	12	250
B42	42	2,5	45	44,5	16	250
B45	45	2,5	48	47,5	16	200
B48	48	2,5	51	50,5	16	200
B50	50	2,5	53	52,5	16	200
B55	55	3,2	58,9	58,2	20	200
B60	60	3,2	63,9	63,2	20	200
B65	65	3,2	68,9	68,2	20	200

Lieferbar in Stahl

Weitere Maße auf Anfrage

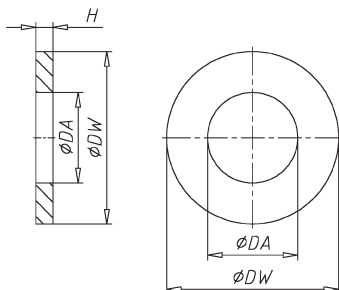

Maße in mm

DA	2,7	3,2	3,7	4,3	5,3	6,4	7,4			
DW	8	9	11	12	15	18	22			
H	0,8	0,8	0,8	1	1,2	1,6	2			
VPE	1000	1000	1000	1000	1000	1000	1000	1000	1000	
DA	8,4	10,5	13	15	17	20	22	26	33	39
DW	24	30	37	44	50	56	60	72	92	110
H	2	2,5	3	3	3	4	4	5	6	8
VPE	500	200	100	100	100	100	100	50	50	25

Lieferbar in Stahl (100 HV), Messing, Polyamid, Aluminium sowie Edelstahl A2 und Edelstahl A4

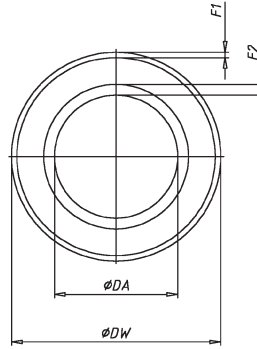
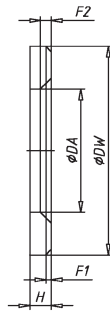

Maße in mm

DA	13	17	21	23	25	28	31	37
DW	24	30	37	39	44	50	56	66
H	3	4	4	4	4	5	5	6
VPE	400	200	200	200	200	100	100	50

Lieferbar in Stahl C45



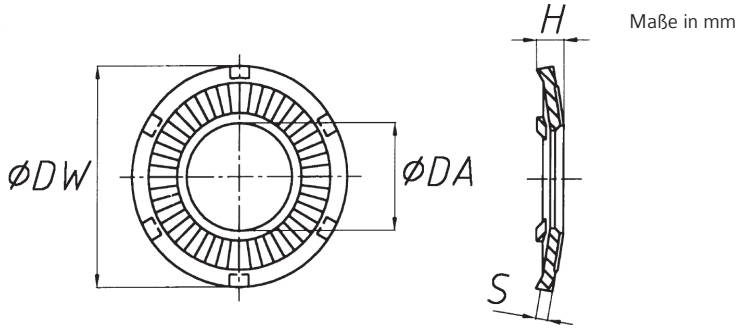

Maße in mm

Nennmaß	DA	DW	H	S	VPE
M3	3,35	6,2	0,95	0,63	1000
M4	4,4	8,2	1,15	0,83	1000
M5	5,4	10,2	1,5	1,03	1000
M6	6,4	12,2	1,8	1,24	1000
M8	8,5	16,2	2,4	1,44	1000
M10	10,56	20,25	2,6	1,64	500
M12	12,8	24,25	2,6	1,64	500
M16	16,8	32,3	3,95	2,56	200

Kontaktscheiben werden vorwiegend verwendet, um elektrisch leitende Erdverbindungen an lackierten Geräteteilen herzustellen. Die Lackschicht darf 100 µm nicht überschreiten. Es ist darauf zu achten, dass die Zähne der Kontaktscheibe in die zu verschraubenden Teile eindringen und einen metallischen Kontakt herstellen.

Werkstoffhärte 420 - 510 HV, Anzahl der Zähne: 6

Ähnlich SN 70093 / NFE 25511 Form K

Maße vorbehaltlich produktionsbedingter Änderungen.

Lieferbar in Stahl

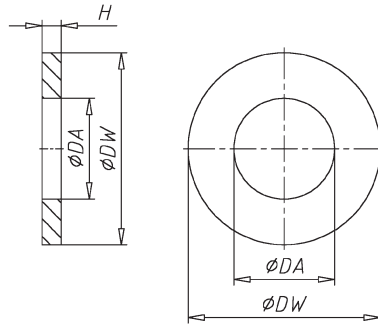

Maße in mm

Nennmaß	DA	DW	H ¹⁾	VPE
4,3x15	4,3	15	1,25	1000
4,3x20	4,3	20	1,25	1000
4,3x25	4,3	25	1,25	1000
5,3x15	5,3	15	1,25	200
5,3x20	5,3	20	1,25	200
5,3x25	5,3	25	1,25	200
5,3x30	5,3	30	1,25	200
6,4x20	6,4	20	1,25	200
6,4x25	6,4	25	1,25	200
6,4x30	6,4	30	1,25	200
6,4x35	6,4	35	1,25	200
6,4x40	6,4	40	1,25	200
8,4x20	8,4	20	1,25	200

Nennmaß	DA	DW	H ¹⁾	VPE
8,4x25	8,4	25	1,25	200
8,4x30	8,4	30	1,25	200
8,4x35	8,4	35	1,25	200
8,4x40	8,4	40	1,25	200
10,5x20	10,5	20	1,25	200
10,5x25	10,5	25	1,25	200
10,5x30	10,5	30	1,25	200
10,5x35	10,5	35	1,25	200
10,5x40	10,5	40	1,25	100
12,5x30	12,5	30	1,25	100
12,5x35	12,5	35	1,25	100
12,5x40	12,5	40	1,25	100

¹⁾ Herstellungsbedingte Abweichungen möglich.
Lieferbar in Stahl sowie Edelstahl A2





Maße in mm

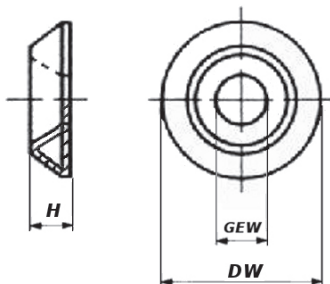

Nennmaß	FORM	Passend für	DW	H	VPE
NR94	Auflagefläche offen	M2,5 + M3	9	2	500
NR103	Auflagefläche offen	M3	10	2	500
NR115	Auflagefläche offen	M3,5	11	2	500
NR125	Auflagefläche offen	M4	12,5	2,3	500
NR136	Auflagefläche offen	M5	13	2	500
NR157	Auflagefläche offen	M5	15	2,8	500
NR168	Auflagefläche offen	M6	16	3,2	500
NR187	Auflagefläche offen	M6	18	3,2	500
NR4094	Auflagefläche geschlossen	M2,5 + M3	9	2,5	500
NR4115	Auflagefläche geschlossen	M3,5	11	2,5	500
NR4125	Auflagefläche geschlossen	M4	11	2,5	500
NR4136	Auflagefläche geschlossen	M5	13	2,5	500
NR4157	Auflagefläche geschlossen	M6	15	3,8	500

Maße vorbehaltlich produktionsbedingter Änderungen.
Lieferbar in Messing

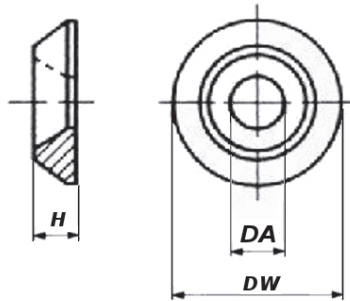

Maße in mm

Nennmaß	DA	DW	H	VPE
4	4,5	11	2,5	200
5	5,5	14	3	200
6	7	16	3,5	200
8	9	22	4,5	50
10	11	28	5,5	50

Rosetten 90° aus Vollmaterial 1.4305, geeignet für Spanlattenschrauben WN57.
Maße vorbehaltlich produktionsbedingter Änderungen.
Lieferbar in Edelstahl





Maße in mm

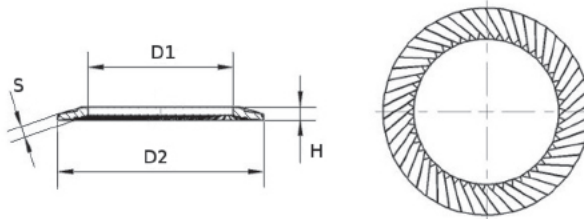

Nennmaß	D1	D2	S	VPE
S2	2,2	4	0,35	1000
S2,5	2,7	4,8	0,45	1000
S3	3,2	5,5	0,45	1000
S3,5	3,7	6	0,45	1000
S4	4,3	7	0,5	1000
S5	5,3	9	0,6	1000
S6	6,4	10	0,7	1000
S7	7,4	12	0,7	500
S8	8,4	13	0,8	500
S10	10,5	16	1	250
S12	13	18	1,1	100
S14	15	22	1,2	100
S16	17	24	1,3	100
S20	21	30	1,5	100
S22	23	33	1,5	100
S24	25,6	36	1,8	100
S27	28,6	39	2	100
S30	31,6	45	2	50
S36	38	54	2,5	50

Die Original Schnorr Sicherungsscheibe Typ S ist für normale Beanspruchung geeignet.
 Lieferbar in Stahl sowie Edelstahl

Maße in mm

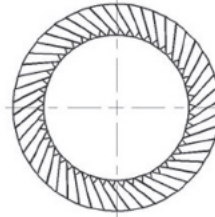
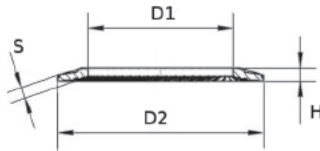

Nennmaß	D1	D2	S	VPE
VS5	5,3	9	1	1000
VS6	6,4	10	1	1000
VS8	8,4	13	1,2	500
VS10	10,5	16	1,5	250
VS12	13	18	1,5	250
VS14	15	22	1,5	200
VS16	17	24	2	100
VS20	21	30	2	100
VS24	25,6	36	2,5	100
VS27	28,6	39	2,5	50
VS30	31,6	45	2,5	50

Die Original Schnorr Sicherungsscheibe Typ VS mit verstärkter Blechdicke, kann ohne Einschränkungen bei hochfesten Schrauben der Festigkeitsklasse 8.8 eingesetzt werden. Die verstärkte Sicherungsscheibe Typ VS weist eine größere Dicke auf und erreicht dadurch höhere Vorspannkkräfte.

Lieferbar in Stahl sowie Edelstahl





Maße in mm

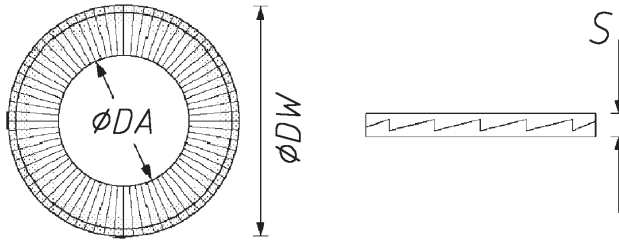

Nennmaß	DA	DW	S	VPE
3	3,4	7,0	1,8	200
4	4,4	7,6	1,8	200
4 SP	4,4	9,0	1,8	200
5	5,4	9,0	1,8	200
5 SP	5,4	10,8	1,8	200
6	6,5	10,8	1,8	200
6 SP	6,5	13,5	2,5	200
8	8,7	13,5	2,5	200
8 SP	8,7	16,6	2,5	200
10	10,7	16,6	2,5	200
10 SP	10,7	21,0	2,5	200
11	11,4	18,5	2,5	200
12	13,0	19,5	2,5	200
12 SP	13,0	25,4	3,4	200
14	15,2	23,0	3,4	100
16	17,0	25,4	3,4	100
16 SP	17,0	30,7	3,4	100
18	19,5	29,0	3,4	100
20	21,4	30,7	3,4	100
20 SP	21,4	39,0	3,4	100
22	23,4	34,5	3,4	100
24	25,3	39,0	3,4	100
24 SP	25,3	48,5	4,6	100

Nennmaß	DA	DW	S	VPE
27	28,4	42,0	5,8	50
30	31,4	47,0	5,8	50
33	34,4	48,5	5,8	25
36	37,4	55,0	6,6	25
42	43,2	63,0	6,6	25

Das Nord-Lock Keilsicherungsscheibenpaar ist nach DIN 25 201 ein in der Verschraubung mitverspanntes Keilscheibenpaar, dessen Keilwirkung jede Neigung zu Selbstlöseerscheinungen verhindert. Paarweise verklebt.

Lieferbar in Stahl sowie Edelstahl A4





Maße in mm

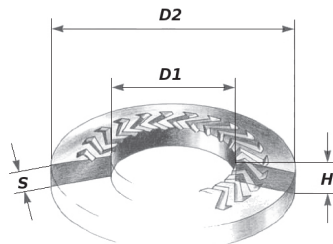

Nennmaß	D1	D2	H	S	Anziehdrehmoment ¹⁾	VPE
SKM4	4,1 +0,48	10,2 -0,40	1,5	1	3,3 / 4,9	8000
SKM5	5,1 +0,48	12,2 -0,40	1,8	1,2	6,7 / 9,8	8000
SKM6	6,1 +0,48	14,2 -0,43	2,2	1,4	11,5 / 16,5	7000
SKM8	8,2 +0,58	18,2 -0,52	2,4	1,4	27 / 40	3000
SKM10	10,2 +0,58	22,25 -0,52	2,75	1,6	54 / 79	1500
SKM12	12,4 +0,58	27,25 -0,52	3,05	1,8	92 / 135	1000
SKM14	14,4 +0,58	30,25 -0,62	3,5	2,4	145 / 215	800
SKM16	16,4 +0,58	32,5 -0,62	3,95	2,5	225 / 330	600
SKM20	21,0 +0,75	40,0 -0,62	4,7	3	460 / 650	400
SKM24	25,0 +0,75	50,0 -0,62	5,6	3,5	790 / 1120	200

Die Sperrkantscheibe verhindert das selbsttätige Lösen einer Schraubenverbindung. Beschädigungen der Anlageflächen und dadurch bedingte Streuungen bei den Anziehdrehmomenten, wie sie bei Schraubensicherungen mit Verzahnungen oder Einkerbungen auftreten, werden bei Sperrkantscheiben durch die besondere geometrische Form der Sperrkanten vermieden.

Weitere Formen auf Anfrage erhältlich.

Lieferbar in Stahl

¹⁾ Anziehdrehmomente (Nm) für Güte 8.8 / 10.9

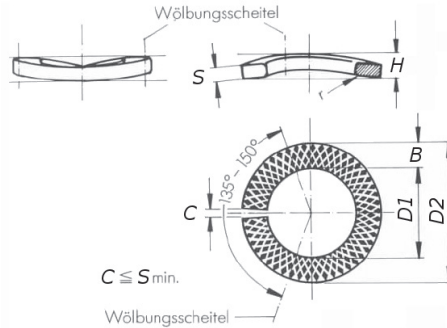

Maße in mm

Nennmaß	D1	D2	B	H max	S	VPE
VSK4	4,1	7,6	1,5	1,4	0,8	1000
VSK5	5,1	9,2	1,8	1,7	1	1000
VSK6	6,1	11,8	2,5	2,2	1,3	1000
VSK8	8,1	14,8	3	2,75	1,6	1000
VSK10	10,2	18,1	3,5	3,15	1,8	1000
VSK12	12,2	21,1	4	3,65	2,1	500
VSK14	14,2	24,1	4,5	4,3	2,4	500
VSK16	16,2	27,4	5	5,1	2,8	250
VSK20	20,2	33,6	6	5,9	3,2	100
VSK22	22,5	35,9	6	5,9	3,2	100
VSK24	24,5	40	7	7,5	4	100

Der Sperrkantring bewirkt ein hohes Maß an Sicherheit für stark beanspruchte Schraubenverbindungen. Die Sperrkanten sind gitterförmig und so zueinander geordnet, dass sie eine Vielzahl von Berührungspunkten zur Gegenlage haben. Die genau aufeinander abgestimmten Sperrkanten drücken sich nur soweit ins Gegenmaterial ein, bis eine Verriegelung gewährleistet ist.

Weitere Formen auf Anfrage erhältlich.

Lieferbar in Stahl



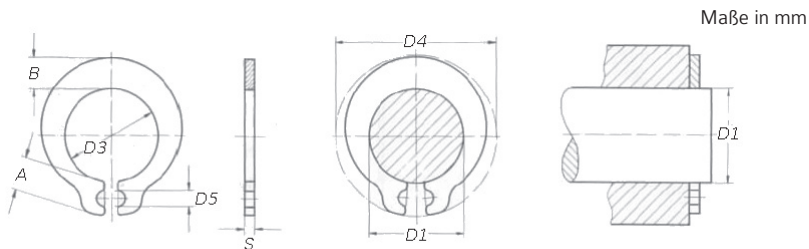

$$D4 = D1 + 2A$$

Nennmaß	D1	D3	D4	D5	A	B	S	VPE
G1,5	1,5	1,4	5,1	0,9	1,7	0,7	0,4	5000
G2	2	1,9	6	0,9	1,9	1	0,6	1000
G2,5	2,5	2,35	6,5	0,9	1,9	1,2	0,6	1000
G2,8	2,8	2,65	7	0,9	2	1,3	0,6	1000
G3	3	2,85	7,4	0,9	2,1	1,4	0,6	1000
G3,5	3,5	3,3	8,3	0,9	2,3	1,6	0,6	1000
G4	4	3,8	9,6	1,2	2,7	1,8	0,8	1000
G5	5	4,75	11	1,3	2,9	2,2	0,8	1000
G5,5	5,5	5,2	11,7	1,3	3	2,2	0,8	1000
G6	6	5,7	12,6	1,4	3,2	2,4	1	1000
G7	7	6,7	14	1,4	3,4	2,7	1	1000
G8	8	7,7	15,2	1,4	3,5	3	1	500
G9	9	8,65	18,6	2	4,7	3,3	1,2	500
G10	10	9,65	19,6	2	4,7	3,5	1,2	500
G11	11	10,6	20,8	2	4,8	4,2	1,2	500
G12	12	11,6	21,8	2	4,8	4,6	1,2	500
G13	13	12,55	23,8	2	5,3	5	1,2	200
G14	14	13,5	25	2,2	5,1	5,4	1,5	200
G15	15	14,5	26,4	2,2	5,1	5,6	1,5	200
G16	16	15,4	27,8	2,5	5,6	5,8	1,5	200
G17	17	16,35	29,5	2,5	6	6,2	1,75	200
G18	18	17,3	31,4	2,5	6,1	6,6	1,75	200
G20	20	19,3	34,4	2,5	6,1	7,1	1,75	100

Maße vorbehaltlich produktionsbedingter Änderungen.
Lieferbar in Stahl

Maße in mm

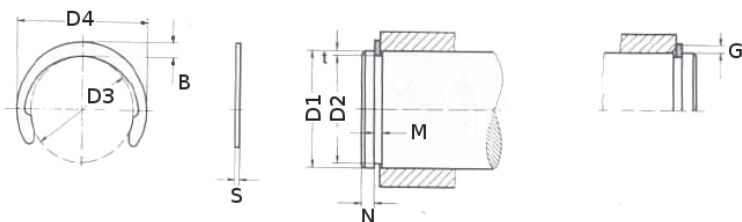

Nennmaß	D1	D2	D3	D4	M	N	B	G	S	VPE
H3	3	2,3	2,18	3,98	0,44	1	0,9	0,4	0,4	5000
H4	4	3,2	3	5	0,44	1,2	1	0,4	0,4	5000
H5	5	4	3,8	6,2	0,64	1,5	1,2	0,6	0,6	5000
H6	6	5	4,8	7,4	0,74	1,5	1,3	0,7	0,7	5000
H7	7	6	5,8	8,6	0,85	1,5	1,4	0,8	0,8	5000
H8	8	7	6,8	10	0,85	1,5	1,6	0,8	0,8	1000
H9	9	8	7,8	11,2	1,1	1,5	1,7	1	1	1000
H10	10	9	8,75	12,15	1,1	1,5	1,7	1	1	1000
H11	11	10	9,65	13,2	1,1	1,5	1,8	1	1	1000
H12	12	10,9	10,55	14,35	1,1	1,7	1,9	1	1	1000
H13	13	11,8	11,4	15,4	1,1	1,8	2	1	1	1000
H15	15	13,6	13,2	17,4	1,1	2,1	2,1	1	1	1000
H16	16	14,5	14,1	18,5	1,1	2,3	2,2	1	1	1000
H17	17	15,4	14,9	19,4	1,1	2,4	2,25	1	1	1000
H18	18	16,3	15,8	20,4	1,3	2,6	2,3	1,2	1,2	1000
H19	19	17,2	16,7	21,5	1,3	2,7	2,4	1,2	1,2	1000
H20	20	18,1	17,55	22,65	1,3	2,9	2,55	1,2	1,2	1000
H22	22	19,9	19,4	25	1,3	3,2	2,8	1,2	1,2	1000
H28	28	25,2	24,6	31,6	1,6	4,2	3,5	1,5	1,5	1000
H30	30	27	26,3	33,7	1,6	4,5	3,7	1,5	1,5	1000

Maße vorbehaltlich produktionsbedingter Änderungen.
Lieferbar in Stahl





Maße in mm

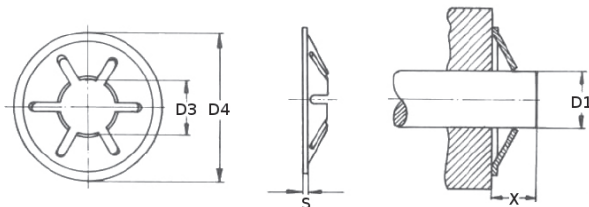

Nennmaß	D1	D3	D4	S	VPE
KS2	2	1,8	7	0,3	5000
KS2,5	2,5	2,3	8,25	0,3	5000
KS3	3	2,8	10	0,4	2500
KS4	4	3,75	13	0,5	1000
KS5	5	4,75	15	0,5	1000
KS6	6	5,75	16,5	0,6	1000
KS7	7	6,75	18	0,6	1000
KS8	8	7,75	19,5	0,7	1000
KS9	9	8,75	21	0,7	1000
KS10	10	9,75	22	0,8	1000

Maße vorbehaltlich produktionsbedingter Änderungen.
Lieferbar in Stahl

Maße in mm

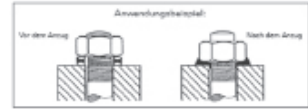
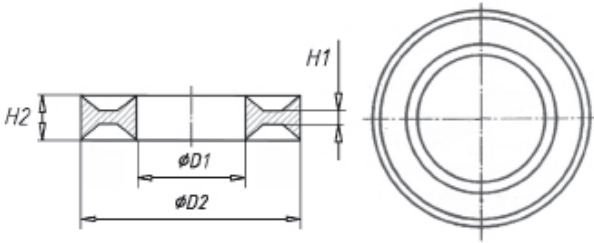

Nennmaß	D1	D2	H1	H2	VPE
M 3 6KT	3,1	8	2,2	0,7	100
M 4 6KT	4,1	9,5	2,6	0,9	100
M 5 6KT	5,1	10,8	3	1,1	100
M 6 6KT	6,2	13	3,6	1,3	100
M 8 6KT	8,1	16,4	4,1	1,5	100
M 10 6KT	10,2	19,8	4,6	1,7	100
M 12 6KT	12,2	23,8	5,1	1,9	100
M 14 6KT	14,2	25,6	5,5	2	100
M 16 6KT	16,2	29,5	6	2,1	100
M 20 6KT	20,3	35,8	7	2,3	100
M 24 6KT	24,4	41,6	7,9	2,5	100
M 27 6KT	27,2	47,2	8,6	2,6	100
M 30 6KT	30,3	53,3	8,7	2,7	100
M 33 6KT	33,1	57,6	8,9	2,9	100
M 36 6KT	36,1	63,4	10,1	3,1	100

Die DUBOSCHWEITZER® Schraubensicherungen sind eine ideale Sicherung, Abdichtung und Isolation Ihrer Schraubverbindungen. Vorteile: - Vielfache Sicherung und Abdichtung - Geräuschdämpfung und Dauerhaftigkeit - Isolierung und Material-, Oberflächenschutz

Bei Schraubensicherungen mit Festigkeitseigenschaften ab 8.8 sind zusätzlich noch Zahntellerringe (N0451) oder die DSL-Doppelsicherung vorzusehen!

Lieferbar in Polyamid 6





Maße in mm

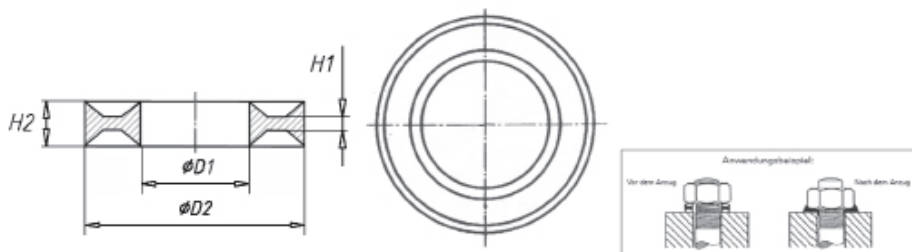

Nennmaß	D1	D2	H1	H2	VPE
M 4 I6KT	4	7,9	0,7	2	100
M 5 I6KT	5,1	9,8	1,1	3	100
M 6 I6KT	6,4	10,6	1,2	3,1	100
M 8 I6KT	8	14,2	1,4	3,4	100
M 10 I6KT	10,1	17	1,4	3,8	100
M 12 I6KT	12,1	19	1,9	4,4	100
M 16 I6KT	15,9	25,2	1,9	5,7	100
M 20 I6KT	20,1	31,5	2,4	6,5	100
M 24 I6KT	24,4	37,6	2,9	7	100

Die DUBOSCHWEITZER® Schraubensicherungen sind eine ideale Sicherung, Abdichtung und Isolation Ihrer Schraubverbindungen. Vorteile: - Vielfache Sicherung und Abdichtung - Geräuschdämpfung und Dauerhaftigkeit - Isolierung und Material, Oberflächenschutz

Bei Schraubensicherungen mit Festigkeitseigenschaften ab 8.8 sind zusätzlich noch Zahntellerringe (N0451) oder die DSL-Doppelsicherung vorzusehen!

Lieferbar in Polyamid 6

Maße in mm

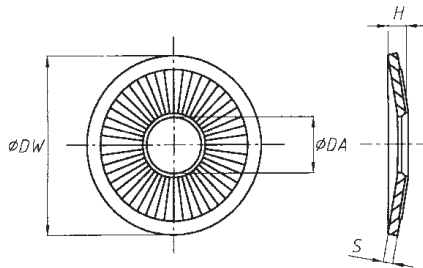

Nennmaß	DA	DW	H	VPE
S3	3,35	6,24	0,9	200
S4	4,4	8,25	1,2	200
S5	5,4	10,29	1,5	200
S6	6,4	12,35	1,85	200
S8	8,56	16,35	2,2	200
S10	10,56	20,42	2,6	200
S12	12,83	24,42	2,9	100
M3	3,35	8,29	1,0	200
M4	4,40	10,29	1,4	200
M5	5,4	12,35	1,8	200
M6	6,4	14,35	2,1	200
M8	8,56	18,35	2,35	200

Nennmaß	DA	DW	H	VPE
M10	10,56	22,42	2,75	200
M12	12,83	27,42	3,1	100
M16	16,83	32,5	4,1	50
M20	21,02	40,5	4,9	50
L3	3,35	10,35	1,2	200
L4	4,4	14,35	1,8	200
L5	5,4	16,35	2,1	200
L6	6,4	18,35	2,5	200
L8	8,56	22,42	2,7	200
L10	10,56	27,42	3,1	200
L12	12,83	32,5	3,6	100

Scheibe mit hoher elastischer Wirkung. Für alle Bereiche, wo verstärkter Schutz gegen Losdrehen und Lockern gefordert ist, so dass die Schraube bei großen Auflageflächen nicht ausdreht. In den Ausführungen: S = small, M = medium, L = large
 Werkstoffhärte: 420 - 510 HV
 Lieferbar in Stahl







1



2



3



4



5



6



7



8



9





Maße in mm

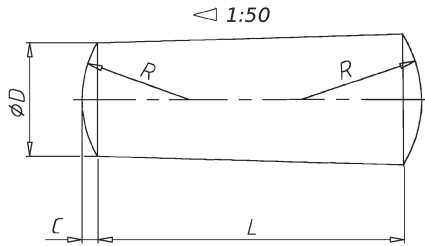

D	1,5	2	2,5	3	4	5	6	8	10	12	16
R	1,6	2,5	2,5	4	4	6	6	10	10	12	16
C max	0,23	0,3	0,4	0,45	0,6	0,75	0,9	1,2	1,5	1,8	2,5

Form A: geschliffen

Form B: gedreht (lagerhaltig)

VPE

L \ D	1,5	2	2,5	3	4	5	6	8	10	12	16
6	200	–	–	–	–	–	–	–	–	–	–
8	200	200	200	–	–	–	–	–	–	–	–
10	200	200	200	200	200	200	–	–	–	–	–
12	200	200	200	200	200	200	–	–	–	–	–
14	200	200	200	200	200	200	–	–	–	–	–
16	200	200	200	200	200	200	200	–	–	–	–
18	200	200	200	200	200	200	200	–	–	–	–
20	200	200	200	200	200	200	200	100	–	–	–
22	–	200	200	200	200	200	200	–	–	–	–
24	–	200	200	200	200	200	200	100	–	–	–
26	–	200	200	200	200	200	200	100	–	–	–
28	–	200	200	200	200	200	200	100	100	–	–
30	–	200	200	200	200	200	200	100	100	–	–
32	–	200	200	200	200	200	200	100	100	–	–
36	–	200	200	200	200	200	200	100	100	50	–
40	–	200	200	200	200	100	100	100	100	50	–
45	–	–	–	200	200	100	100	100	100	50	–
50	–	200	200	200	200	100	100	100	100	50	25
55	–	–	–	–	–	100	100	100	100	50	–
60	–	–	–	100	200	100	100	100	100	50	25
65	–	–	–	–	200	100	100	100	–	–	–
70	–	–	–	100	200	100	100	100	50	50	25
80	–	–	–	–	200	100	100	100	50	50	25
90	–	–	–	–	–	100	100	100	50	50	–
100	–	–	–	–	100	100	100	100	50	50	25
120	–	–	–	–	–	–	–	50	50	25	25

Die handelsüblichen Größen sind durch Angabe der VPE gekennzeichnet.
Lieferbar in Stahl sowie NIRO.





Maße in mm

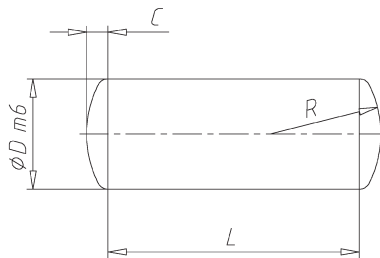

D	1	1,5	2	2,5	3	4	5	6	8	10	12	16	20
C max	0,15	0,23	0,3	0,4	0,45	0,6	0,75	0,9	1,2	1,5	1,8	2,5	3
R	1	1,6	2	2,5	3	4	5	6	8	10	12	16	20

Toleranzfeld: m6

Achtung: Kuppen werden bei der Längenangabe nicht berücksichtigt.

VPE

L \ D	2	2,5	3	4	5	6	8	10	12
3	500	–	–	–	–	–	–	–	–
4	500	–	–	–	–	–	–	–	–
5	500	–	500	200	–	–	–	–	–
6	500	500	500	200	200	200	–	–	–
8	500	500	500	200	200	200	100	–	–
10	500	500	500	200	200	200	100	50	–
12	500	500	500	200	200	200	100	50	–
14	500	500	500	200	200	200	100	50	–
16	500	500	500	200	200	200	100	50	50
18	500	500	500	200	200	200	100	50	50
20	500	500	500	200	200	200	100	50	50
22	–	500	500	200	200	200	100	50	50
24	500	500	500	200	200	200	100	50	50
26	–	–	500	200	200	200	100	50	50
28	–	–	500	200	200	200	100	50	50
30	–	–	200	200	200	200	100	50	50
32	–	–	200	200	200	200	100	50	25
36	–	–	200	200	200	200	100	50	25
40	–	–	200	200	200	200	100	50	25
45	–	–	200	200	200	100	100	50	25
50	–	–	200	200	100	100	100	50	25
55	–	–	–	200	100	100	100	50	25
60	–	–	200	200	100	100	100	50	25
70	–	–	–	200	100	100	100	50	25
80	–	–	–	200	100	100	100	50	25
90	–	–	–	–	–	100	100	50	25
100	–	–	–	–	–	100	100	50	25
120	–	–	–	–	–	–	100	50	25
140	–	–	–	–	–	–	100	50	25

Die handelsüblichen Größen sind durch Angabe der VPE gekennzeichnet.
Lieferbar in Stahl sowie NIRO.





Maße in mm

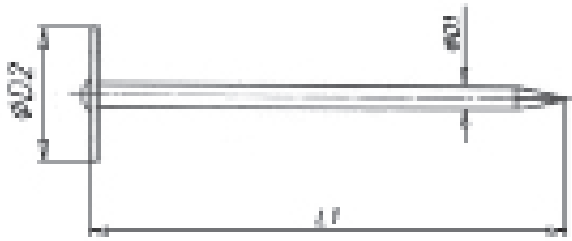

Nennmaß	D2	VPE
31/40	20	2,5 kg
31/60	20	2,5 kg
34/80	20	2,5 kg
38/100	20	2,5 kg

Form A: Runder Kopf
 Form B: Vierkant Kopf
 Lieferbar in Stahl

Maße in mm

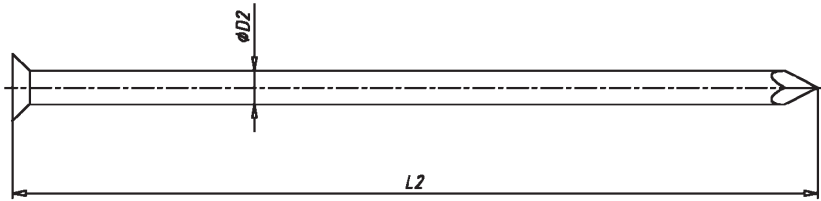

Nennmaß	VPE
1x15	1 kg
1,2x20	1 kg
1,4x25	1 kg
1,6x30	1 kg
1,8x35	2,5 kg
2x40	2,5 kg
2,2x45	2,5 kg
2,2x50	2,5 kg
2,5x55	2,5 kg
2,5x60	2,5 kg
2,8x65	2,5 kg
3,1x65	2,5 kg
3,1x70	2,5 kg
3,1x80	2,5 kg
3,4x80	5 kg

Nennmaß	VPE
3,4x90	5 kg
3,8x100	5 kg
4,2x110	5 kg
4,2x120	5 kg
4,6x130	5 kg
5,5x140	5 kg
5,5x160	5 kg
6x180	5 kg
7x210	5 kg
7,6x230	5 kg
7,6x260	5 kg
8,8x260	5 kg
8,8x290	5 kg
9,0x300	5 kg
9,4x310	5 kg

Lieferbar in Stahl



1



2



3



4



5



6



7



8



9

Maße in mm

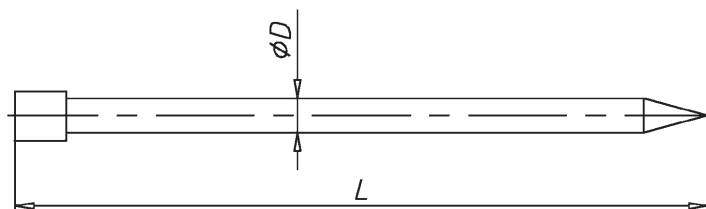

Nennmaß	VPE	Nennmaß	VPE
1x15	1 kg	2,2x50	2,5 kg
1,2x20	1 kg	2,2x55	2,5 kg
1,4x25	1 kg	2,5x60	2,5 kg
1,6x30	1 kg	2,8x65	2,5 kg
1,8x35	2,5 kg	3,1x80	2,5 kg
2x40	2,5 kg	3,4x90	5 kg
2,2x45	2,5 kg	3,8x100	5 kg

Lieferbar in Stahl

Maße in mm

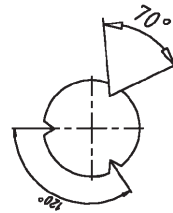
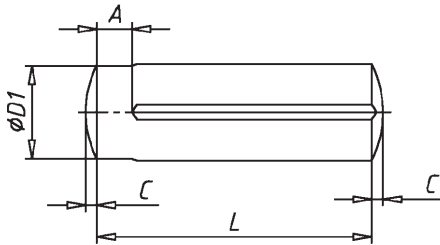

D1	2	2,5	3	4	5	6	8	10
A	0,7	1	1	1,5	1,5	2	2	2,5
C	0,25	0,3	0,4	0,5	0,6	0,8	1	1,2
MA ¹ (kN)	2,84	4,4	6,4	11,3	17,6	25,4	45,2	70,4

¹ Mindest-Abscherkraft zweischneitig für Kerbstifte aus Stahl

VPE

L / D1	2	2,5	3	4	5	6	8	10
10	1000	1000	1000	500	–	–	–	–
12	1000	1000	1000	500	–	–	–	–
16	1000	1000	1000	500	500	500	–	–
20	500	1000	1000	500	500	500	250	–
24	–	–	1000	500	500	500	250	–
26	–	–	500	500	500	500	250	–
30	–	–	500	500	250	500	500	–
40	–	–	–	–	250	250	250	100
50	–	–	–	–	–	–	250	100
60	–	–	–	–	–	–	250	100

Kerben: Form nach Wahl des Herstellers

Der Bohrdurchmesser entspricht dem Nenndurchmesser (\varnothing D1). Toleranzfeld H11

Werkstoff: Stahl (125 HV bis 245 HV) Nichtrostender Stahl A1 (210 HV bis 280 HV)

Die handelsüblichen Größen sind durch Angabe der VPE gekennzeichnet.

Lieferbar in Stahl sowie NIRO





Maße in mm

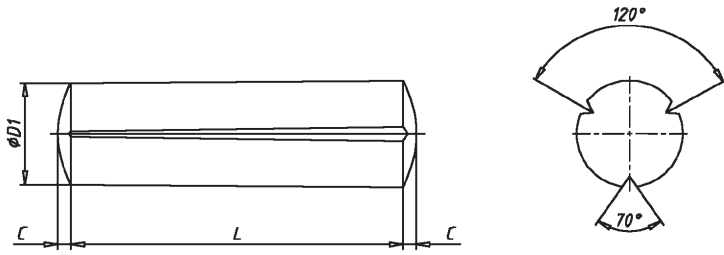

D1	1,5	2	2,5	3	4	5	6	8	10	12	16
C	0,2	0,25	0,3	0,4	0,5	0,63	0,8	1	1,2	1,6	2

VPE

L / D1	1,5	2	2,5	3	4	5	6	8	10	12	16
5	1000	1000	-	-	-	-	-	-	-	-	-
6	1000	1000	1000	1000	500	-	-	-	-	-	-
8	1000	1000	1000	1000	500	500	-	-	-	-	-
10	1000	1000	1000	1000	500	500	500	-	-	-	-
12	1000	1000	1000	1000	500	500	500	-	-	-	-
14	1000	1000	1000	1000	500	500	500	-	-	-	-
16	1000	1000	1000	1000	500	500	500	500	-	-	-
20	-	1000	1000	1000	500	500	500	500	100	-	-
22	-	-	-	1000	500	500	500	500	100	-	-
24	-	-	-	500	500	250	500	500	100	100	-
26	-	-	-	500	500	250	500	500	100	100	-
28	-	-	-	500	500	250	500	500	100	100	-
30	-	-	-	500	250	250	500	250	100	100	-
32	-	-	-	-	250	250	500	250	100	100	-
36	-	-	-	-	250	250	500	250	100	100	-
40	-	-	-	-	250	250	250	250	100	100	50
50	-	-	-	-	-	250	250	250	100	100	50
60	-	-	-	-	-	-	250	250	100	100	50
70	-	-	-	-	-	-	-	250	100	100	50
80	-	-	-	-	-	-	-	250	100	100	50
90	-	-	-	-	-	-	-	-	100	100	50
100	-	-	-	-	-	-	-	-	-	100	50
120	-	-	-	-	-	-	-	-	-	-	50

Kerben: Form nach Wahl des Herstellers
 Der Bohrdurchmesser entspricht dem Nenndurchmesser ($\varnothing D1$). Toleranzfeld H11
 Werkstoff: Stahl (125 HV bis 245 HV) Nichtrostender Stahl A1 (210 HV bis 280 HV)
 Die handelsüblichen Größen sind durch Angabe der VPE gekennzeichnet.
 Lieferbar in Stahl sowie NIRO

Maße in mm

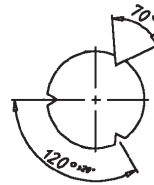
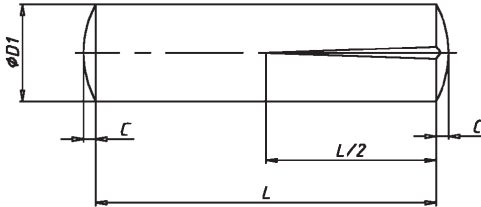

D1	1,5	2	2,5	3	4	5	6	8	10	12	16
C	0,2	0,25	0,3	0,4	0,5	0,6	0,8	1	1,2	1,6	2

VPE

L / D1	1,5	2	2,5	3	4	5	6	8	10	12	16
4	1000	1000	-	-	-	-	-	-	-	-	-
6	1000	1000	1000	1000	1000	-	-	-	-	-	-
8	1000	1000	1000	1000	1000	-	-	-	-	-	-
10	1000	1000	1000	1000	500	500	-	-	-	-	-
12	1000	1000	1000	1000	500	500	500	500	-	-	-
14	-	1000	1000	1000	500	500	500	-	-	-	-
16	-	1000	1000	1000	500	500	500	500	250	-	-
18	-	-	1000	1000	500	500	500	500	250	-	-
20	-	1000	1000	1000	500	500	500	500	250	-	-
22	-	-	-	1000	500	500	500	500	250	-	-
24	-	-	-	1000	500	250	500	500	250	-	-
26	-	-	-	1000	500	250	500	250	250	-	-
28	-	-	-	500	500	250	500	250	250	-	-
30	-	-	-	500	500	250	500	250	250	100	-
32	-	-	-	-	500	250	500	250	250	100	100
36	-	-	-	-	-	250	250	250	250	100	-
40	-	-	-	-	500	250	250	250	250	100	100
45	-	-	-	-	-	-	250	250	250	100	100
50	-	-	-	-	500	250	250	250	250	100	50
60	-	-	-	-	-	250	250	250	250	100	50
70	-	-	-	-	-	-	250	250	250	100	50
80	-	-	-	-	-	-	250	250	250	100	50

Kerben: Form nach Wahl des Herstellers

Der Bohrdurchmesser entspricht dem Nenndurchmesser (\varnothing D1). Toleranzfeld H11

Werkstoff: Stahl (125 HV bis 245 HV) Nichtrostender Stahl A1 (210 HV bis 280 HV)

Die handelsüblichen Größen sind durch Angabe der VPE gekennzeichnet.

Lieferbar in Stahl sowie NIRO

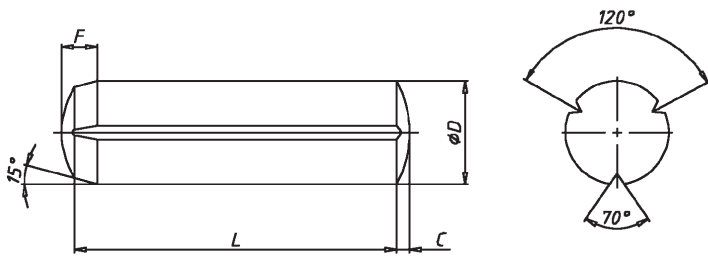

Maße in mm

D	1,5	2	2,5	3	4	5	6	8	10	12	16
C	0,2	0,25	0,3	0,4	0,5	0,6	0,8	1	1,2	1,6	2
F	0,8	0,9	1,2	1,3	1,8	2	2,5	2,8	3,5	3,7	4,3
MA (kN) ¹⁾	1,6	2,84	4,4	6,4	11,3	17,6	25,4	45,2	70,4	101,8	181

¹⁾ Mindest-Abscherkraft zweischnittig für Kerbstifte aus Stahl

VPE

L \ D	1,5	2	2,5	3	4	5	6	8	10	12	16
4	1000	1000	–	–	–	–	–	–	–	–	–
6	1000	1000	1000	1000	500	–	–	–	–	–	–
8	1000	1000	1000	1000	500	500	500	–	–	–	–
10	1000	1000	1000	1000	500	500	500	–	–	–	–
12	1000	1000	1000	1000	500	500	500	500	–	–	–
14	1000	1000	1000	1000	500	500	500	500	–	–	–
16	1000	1000	1000	1000	500	500	500	500	–	–	–
18	1000	1000	1000	1000	500	500	500	500	–	–	–
20	1000	1000	1000	1000	500	500	500	500	250	100	–
24	–	1000	1000	500	500	500	500	500	250	100	–
26	–	–	–	500	500	500	500	500	250	100	–
28	–	–	–	500	250	250	500	500	250	100	–
30	–	–	–	500	250	250	500	500	250	100	–
32	–	–	–	500	250	250	500	500	250	100	–
36	–	–	–	–	250	250	500	500	100	100	100
40	–	–	–	500	250	250	250	500	100	100	100
50	–	–	–	–	250	250	250	250	100	100	100
60	–	–	–	–	250	250	250	250	100	100	100
70	–	–	–	–	–	–	–	250	100	100	50
80	–	–	–	–	–	–	–	250	100	100	50
100	–	–	–	–	–	–	–	–	100	100	50

Kerben: Form nach Wahl des Herstellers

Der Bohrdurchmesser entspricht dem Nenndurchmesser (\varnothing D1). Toleranzfeld H11

Werkstoff: Stahl (125 HV bis 245 HV) Nichtrostender Stahl A1 (210 HV bis 280 HV)

Die handelsüblichen Größen sind durch Angabe der VPE gekennzeichnet.

Lieferbar in Stahl sowie NIRO





Maße in mm

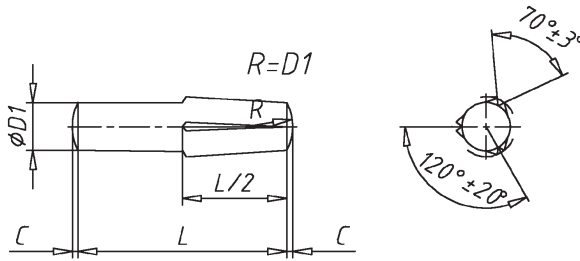

D1	2	2,5	3	4	5	6	8	10
C~	0,25	0,3	0,4	0,5	0,63	0,8	1	1,2

VPE

L / D1	2	2,5	3	4	5	6	8	10
6	1000	–	–	–	–	–	–	–
8	1000	1000	1000	–	–	–	–	–
10	1000	1000	1000	500	500	–	–	–
12	1000	1000	1000	500	500	500	–	–
16	1000	1000	1000	500	500	500	500	–
20	–	–	1000	500	500	500	500	100
24	–	–	1000	500	500	500	500	100
26	–	–	1000	500	500	500	250	100
30	–	–	500	500	500	500	250	100
32	–	–	–	–	500	500	250	100
36	–	–	–	–	500	250	250	100
40	–	–	–	–	250	250	250	100
50	–	–	–	–	250	250	250	100
60	–	–	–	–	–	250	250	100
70	–	–	–	–	–	–	–	100

Kerben: Form nach Wahl des Herstellers

Der Bohrdurchmesser entspricht dem Nenndurchmesser ($\varnothing D1$). Toleranzfeld H11

Werkstoff: Stahl (125 HV bis 245 HV) Nichtrostender Stahl A1 (210 HV bis 280 HV)

Die handelsüblichen Größen sind durch Angabe der VPE gekennzeichnet.

Lieferbar in Stahl sowie NIRO

Maße in mm

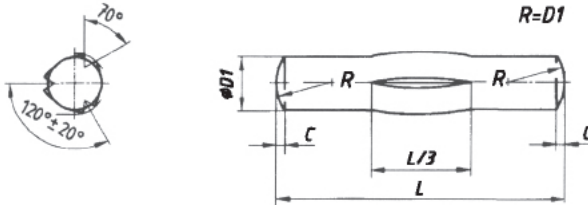

D1	1,5	2	2,5	3	4	5	6	8
C~	0,2	0,25	0,3	0,4	0,5	0,6	0,8	1

VPE

L / D1	1,5	2	2,5	3	4	5	6	8
6	1000	-	-	-	-	-	-	-
8	1000	1000	1000	1000	-	-	-	-
10	1000	1000	1000	1000	-	-	-	-
12	1000	1000	1000	1000	500	500	-	-
16	1000	1000	1000	1000	500	500	-	-
18	-	1000	1000	1000	500	500	-	-
20	-	-	1000	1000	500	500	500	-
22	-	-	1000	1000	500	500	500	-
24	-	-	-	1000	500	500	500	-
26	-	-	-	1000	500	500	500	-
28	-	-	-	-	500	500	500	-
30	-	-	-	-	500	500	500	250
36	-	-	-	-	500	500	500	250
40	-	-	-	-	500	250	250	250
50	-	-	-	-	500	250	250	250
60	-	-	-	-	500	250	250	250
70	-	-	-	-	-	-	250	100
80	-	-	-	-	-	-	250	100
90	-	-	-	-	-	-	-	100
100	-	-	-	-	-	-	-	100

Kerben: Form nach Wahl des Herstellers

Der Bohrdurchmesser entspricht dem Nenndurchmesser (\varnothing D1). Toleranzfeld H11

Werkstoff: Stahl (125 HV bis 245 HV) Nichtrostender Stahl A1 (210 HV bis 280 HV)

Die handelsüblichen Größen sind durch Angabe der VPE gekennzeichnet.

Lieferbar in Stahl sowie NIRO



Maße in mm

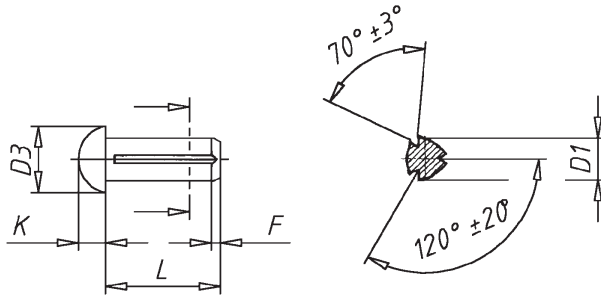

D1	1,4	1,6	2	2,5	3	4	5	6	8
D3	2,4	2,8	3,5	4,4	5,2	7	8,8	10,5	14
K	0,8	1	1,2	1,5	1,8	2,4	3	3,6	4,8
F	0,5	0,5	0,5	0,7	1	1,5	1,5	2	2

VPE

L / D1	1,4	1,6	2	2,5	3	4	5	6	8
3	1000	1000	1000	-	-	-	-	-	-
4	1000	1000	1000	1000	1000	-	-	-	-
5	1000	1000	1000	1000	1000	-	-	-	-
6	1000	1000	1000	1000	1000	1000	-	-	-
8	-	-	1000	1000	1000	1000	500	500	-
10	-	-	1000	1000	1000	500	500	500	250
12	-	-	-	-	1000	500	500	500	250
15	-	-	-	-	1000	500	500	500	250
20	-	-	-	-	-	500	500	500	250
25	-	-	-	-	-	-	500	500	250
30	-	-	-	-	-	-	-	500	250

Kerben: Form nach Wahl des Herstellers

Der Bohrdurchmesser entspricht dem Nenndurchmesser (Ø D1). Toleranzfeld H11

Werkstoff: Stahl (125 HV bis 245 HV) Andere Werkstoffe nach Vereinbarung

Die handelsüblichen Größen sind durch Angabe der VPE gekennzeichnet.

Lieferbar in Stahl, Aluminium sowie NIRO

Maße in mm

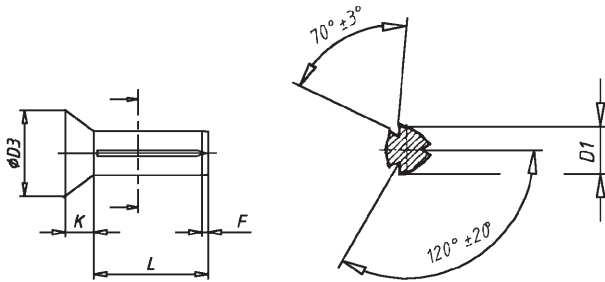

D1	1,7	2	2,6	3	4	5
D3	2,8	3,5	4,4	5,2	7	8,8
F	0,5	0,5	0,7	1	1,5	1,5
K	0,8	1	1,2	1,4	2	2,5

VPE

L / D1	2	3	4
4	1000	–	–
6	1000	1000	1000
8	1000	1000	500
10	1000	1000	500
12	–	1000	–

Kerben: Form nach Wahl des Herstellers

Der Bohrdurchmesser entspricht dem Nenndurchmesser ($\varnothing D1$). Toleranzfeld H11

Werkstoff: Stahl (125 HV bis 245 HV) Andere Werkstoffe nach Vereinbarung

Die handelsüblichen Größen sind durch Angabe der VPE gekennzeichnet.

Lieferbar in Stahl, Aluminium sowie NIRO





Maße in mm

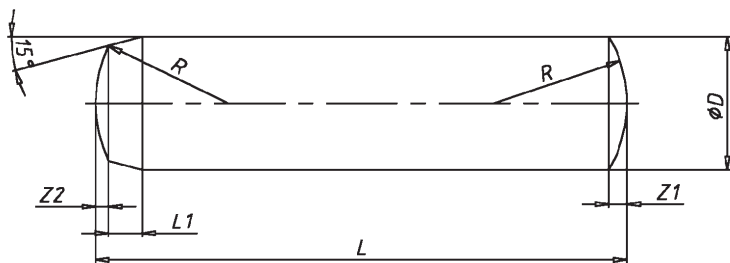

D	1	1,5	2	2,5	3	4	5	6	8	10	12	14	16	20
L1	0,4	0,5	0,6	0,7	0,8	1	1,2	1,5	1,8	2	2,5	2,5	3	4
Z1	0,15	0,23	0,3	0,4	0,45	0,6	0,75	0,9	1,2	1,5	1,8	2	2,5	3
Z2	0,08	0,12	0,18	0,25	0,3	0,4	0,5	0,6	0,8	1	1,3	1,3	1,7	2
R	1	1,6	2	2,5	3	4	5	6	8	10	12	16	16	20

Toleranzfeld: m6
Härte 60 +/- 2HRC

VPE

L \ D	1	1,5	2	2,5	3	4	5	6	8	10	12	14	16	20
4	1000	1000	500	500	–	–	–	–	–	–	–	–	–	–
5	1000	1000	500	500	500	–	–	–	–	–	–	–	–	–
6	1000	1000	500	500	500	200	200	–	–	–	–	–	–	–
8	1000	1000	500	500	500	200	200	100	–	–	–	–	–	–
10	1000	1000	500	500	500	200	200	100	100	–	–	–	–	–
12	1000	1000	500	500	500	200	200	100	100	–	–	–	–	–
14	1000	1000	500	500	500	200	200	100	100	100	–	–	–	–
16	1000	1000	500	500	500	200	200	100	100	100	50	–	–	–
18	1000	1000	500	500	500	200	200	100	100	100	50	–	–	–
20	1000	1000	500	500	500	200	200	100	100	100	50	–	–	–
22	–	1000	500	500	500	200	200	100	100	100	–	–	–	–
24	–	1000	500	500	500	200	200	100	100	100	50	25	25	–
26	–	1000	500	500	500	200	200	100	100	100	50	25	25	–
28	–	500	500	500	500	200	200	100	100	100	50	25	25	–
30	–	500	500	500	500	200	200	100	100	100	50	25	25	–
32	–	–	500	500	200	200	200	100	100	100	50	25	25	25
36	–	–	500	500	200	200	200	100	100	100	50	25	25	25
40	–	–	500	500	200	200	100	100	100	50	50	25	25	25
45	–	–	500	–	200	100	100	100	100	50	50	25	25	25
50	–	–	500	500	200	100	100	100	100	50	50	25	25	25
55	–	–	–	–	200	100	100	100	100	50	50	25	25	25
60	–	–	–	–	200	100	100	100	100	50	50	25	25	25
65	–	–	–	–	–	–	100	100	100	50	50	25	25	25
70	–	–	–	–	–	100	100	100	100	50	50	25	25	25
80	–	–	–	–	–	100	100	100	100	50	50	25	25	25
90	–	–	–	–	–	–	100	100	100	50	50	25	25	25
100	–	–	–	–	–	–	–	50	100	50	50	25	25	25
110	–	–	–	–	–	–	–	–	50	25	50	–	–	–
120	–	–	–	–	–	–	–	–	50	25	50	25	25	25
130	–	–	–	–	–	–	–	–	–	25	50	25	25	25
140	–	–	–	–	–	–	–	–	–	25	25	25	25	25
150	–	–	–	–	–	–	–	–	–	25	25	–	–	–
160	–	–	–	–	–	–	–	–	–	25	25	–	–	–

Die handelsüblichen Größen sind durch Angabe der VPE gekennzeichnet.
Lieferbar in Stahl





1

2

3

4

5

6

7

8

9

Maße in mm

Form A: rundstirnig

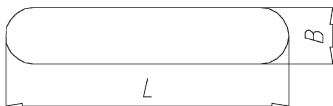

Nennmaß	VPE	Nennmaß	VPE
A2x2x6	100	A3x3x32	100
A2x2x8	100	A3x3x36	100
A2x2x10	100	A3x3x40	100
A2x2x12	100	A4x4x8	100
A2x2x14	100	A4x4x10	100
A2x2x16	100	A4x4x12	100
A2x2x18	100	A4x4x14	100
A2x2x20	100	A4x4x16	100
A2x2x22	100	A4x4x18	100
A2x2x25	100	A4x4x20	100
A3x3x6	100	A4x4x22	100
A3x3x8	100	A4x4x25	100
A3x3x10	100	A4x4x28	100
A3x3x12	100	A4x4x30	100
A3x3x14	100	A4x4x32	100
A3x3x16	100	A4x4x36	100
A3x3x18	100	A4x4x40	100
A3x3x20	100	A4x4x45	100
A3x3x22	100	A4x4x50	100
A3x3x25	100	A5x5x8	100
A3x3x28	100	A5x5x10	100
A3x3x30	100	A5x5x12	100

Nennmaß	VPE	Nennmaß	VPE
A5x5x14	100	A6x6x56	100
A5x5x16	100	A6x6x60	100
A5x5x18	100	A6x6x63	100
A5x5x20	100	A6x6x70	100
A5x5x22	100	A6x6x80	100
A5x5x25	100	A6x6x90	100
A5x5x28	100	A6x6x100	100
A5x5x30	100	A8x7x10	100
A5x5x32	100	A8x7x12	100
A5x5x36	100	A8x7x14	100
A5x5x40	100	A8x7x16	100
A5x5x45	100	A8x7x18	100
A5x5x50	100	A8x7x20	100
A5x5x56	100	A8x7x22	100
A5x5x60	100	A8x7x25	100
A5x5x63	100	A8x7x28	100
A5x5x70	100	A8x7x30	100
A6x6x10	100	A8x7x32	100
A6x6x12	100	A8x7x36	100
A6x6x14	100	A8x7x40	100
A6x6x16	100	A8x7x45	100
A6x6x18	100	A8x7x50	100
A6x6x20	100	A8x7x56	100
A6x6x22	100	A8x7x60	100
A6x6x25	100	A8x7x63	100
A6x6x28	100	A8x7x70	100
A6x6x30	100	A8x7x80	100
A6x6x32	100	A8x7x90	100
A6x6x36	100	A8x7x100	50
A6x6x40	100	A8x7x110	50
A6x6x45	100	A8x7x125	50
A6x6x50	100	A8x7x140	50





Nennmaß	VPE	Nennmaß	VPE
A10x8x16	100	A12x8x40	50
A10x8x18	100	A12x8x45	50
A10x8x20	100	A12x8x50	50
A10x8x22	100	A12x8x56	50
A10x8x25	100	A12x8x60	50
A10x8x28	100	A12x8x63	50
A10x8x30	100	A12x8x70	50
A10x8x32	100	A12x8x80	50
A10x8x36	100	A12x8x90	50
A10x8x40	100	A12x8x100	25
A10x8x45	100	A12x8x110	25
A10x8x50	100	A12x8x120	25
A10x8x56	50	A12x8x125	25
A10x8x60	50	A12x8x130	25
A10x8x63	50	A12x8x140	25
A10x8x70	50	A12x8x150	25
A10x8x80	50	A12x8x160	25
A10x8x90	50	A14x9x25	50
A10x8x100	25	A14x9x28	50
A10x8x110	25	A14x9x30	50
A10x8x120	25	A14x9x32	50
A10x8x125	25	A14x9x36	50
A10x8x140	25	A14x9x40	50
A10x8x150	25	A14x9x45	50
A10x8x160	25	A14x9x50	50
A12x8x18	50	A14x9x56	50
A12x8x20	50	A14x9x60	50
A12x8x25	50	A14x9x63	50
A12x8x28	50	A14x9x70	25
A12x8x30	50	A14x9x80	25
A12x8x32	50	A14x9x90	25
A12x8x36	50	A14x9x100	25

Nennmaß	VPE	Nennmaß	VPE
A14x9x110	25	A18x11x45	25
A14x9x120	25	A18x11x50	25
A14x9x125	25	A18x11x56	25
A14x9x140	25	A18x11x60	25
A14x9x150	25	A18x11x63	25
A14x9x160	25	A18x11x70	25
A14x9x180	25	A18x11x80	25
A14x9x200	10	A18x11x90	25
A16x10x30	25	A18x11x100	10
A16x10x32	25	A18x11x110	10
A16x10x36	25	A18x11x120	10
A16x10x40	25	A18x11x125	10
A16x10x45	25	A18x11x140	10
A16x10x50	25	A18x11x160	10
A16x10x56	25	A18x11x180	10
A16x10x60	25	A18x11x200	10
A16x10x63	25	A18x11x220	10
A16x10x70	25	A20x12x36	25
A16x10x80	25	A20x12x40	25
A16x10x90	10	A20x12x45	25
A16x10x100	10	A20x12x50	25
A16x10x110	10	A20x12x56	25
A16x10x120	10	A20x12x60	25
A16x10x125	10	A20x12x63	25
A16x10x130	10	A20x12x70	25
A16x10x140	10	A20x12x80	25
A16x10x160	10	A20x12x90	25
A16x10x180	10	A20x12x100	10
A16x10x200	25	A20x12x110	10
A18x11x32	25	A20x12x120	10
A18x11x36	25	A20x12x125	10
A18x11x40	25	A20x12x130	10





Nennmaß	VPE	Nennmaß	VPE
A20x12x140	10	A25x14x90	10
A20x12x150	10	A25x14x100	10
A20x12x160	10	A25x14x110	10
A20x12x180	10	A25x14x125	10
A20x12x200	10	A25x14x140	10
A20x12x220	10	A25x14x150	10
A22x14x60	25	A25x14x160	10
A22x14x63	25	A25x14x180	10
A22x14x70	25	A25x14x200	10
A22x14x80	25	A25x14x220	10
A22x14x90	25	A25x14x250	10
A22x14x100	10	A28x16x70	10
A22x14x110	10	A28x16x80	10
A22x14x120	10	A28x16x90	10
A22x14x125	10	A28x16x100	10
A22x14x140	10	A28x16x110	10
A22x14x160	10	A28x16x125	10
A22x14x180	10	A28x16x140	10
A22x14x200	10	A28x16x160	10
A22x14x220	10	A28x16x180	10
A22x14x250	10	A28x16x200	10
A25x14x63	10	A28x16x220	10
A25x14x70	10	A28x16x250	10
A25x14x80	10		

Nennmaß = (Form) Breite x Höhe x Länge

Werkstoff: bei Passfeder-Höhen (H) bis 25 mm: ST50-1K
 bei Passfeder-Höhen (H) über 25 mm: ST60-2 K
 Lieferbar in Stahl sowie Edelstahl A4

Maße in mm

Form A: rundstirnig

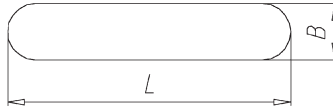
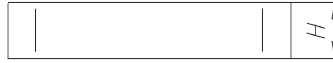

Nennmaß	VPE	Nennmaß	VPE
A5x3x8	100	A6x4x25	100
A5x3x10	100	A6x4x30	100
A5x3x12	100	A6x4x32	100
A5x3x14	100	A6x4x36	100
A5x3x16	100	A6x4x40	100
A5x3x18	100	A6x4x45	100
A5x3x20	100	A6x4x50	100
A5x3x22	100	A6x4x56	100
A5x3x25	100	A6x4x63	100
A5x3x28	100	A6x4x70	100
A5x3x32	100	A8x5x10	100
A5x3x36	100	A8x5x12	100
A5x3x40	100	A8x5x14	100
A5x3x45	100	A8x5x16	100
A5x3x50	100	A8x5x18	100
A6x4x8	100	A8x5x20	100
A6x4x10	100	A8x5x22	100
A6x4x12	100	A8x5x25	100
A6x4x16	100	A8x5x28	100
A6x4x18	100	A8x5x30	100
A6x4x20	100	A8x5x32	100
A6x4x22	100	A8x5x36	100



Nennmaß	VPE	Nennmaß	VPE
A8x5x40	100	A12x6x70	50
A8x5x45	100	A12x6x80	50
A8x5x50	100	A12x6x90	50
A8x5x56	100	A12x6x100	25
A8x5x63	100	A12x6x110	25
A8x5x70	100	A12x6x125	25
A10x6x18	100	A12x6x140	25
A10x6x20	100	A14x6x32	50
A10x6x22	100	A14x6x36	50
A10x6x25	100	A14x6x40	50
A10x6x28	100	A14x6x45	50
A10x6x30	100	A14x6x50	50
A10x6x36	100	A14x6x56	50
A10x6x40	100	A14x6x63	50
A10x6x45	100	A14x6x70	5
A10x6x50	100	A14x6x80	5
A10x6x56	100	A14x6x90	5
A10x6x60	100	A14x6x100	5
A10x6x63	100	A14x6x110	5
A10x6x70	100	A14x6x125	5
A10x6x80	100	A14x6x140	5
A10x6x90	50	A16x7x45	25
A10x6x100	50	A16x7x50	25
A10x6x110	50	A16x7x56	25
A12x6x28	50	A16x7x63	25
A12x6x32	50	A16x7x80	25
A12x6x36	50	A16x7x90	25
A12x6x40	50	A16x7x100	10
A12x6x45	50	A16x7x110	10
A12x6x50	50	A16x7x125	10
A12x6x56	50	A16x7x140	25
A12x6x63	50	A18x7x50	25

Nennmaß	VPE
A18x7x56	25
A18x7x63	25
A18x7x70	25
A18x7x80	25
A18x7x90	25
A18x7x100	25
A18x7x110	25
A18x7x125	10
A18x7x140	10
A20x8x56	25
A20x8x63	25

Nennmaß	VPE
A20x8x70	25
A20x8x80	25
A20x8x90	25
A20x8x100	25
A20x8x110	25
A20x8x125	25
A20x8x140	25
A20x8x160	25
A20x8x180	25
A20x8x200	10

Nennmaß = (Form) Breite x Höhe x Länge

Werkstoff: bei Passfeder-Höhen (H) bis 25 mm: ST50-1K
 bei Passfeder-Höhen (H) über 25 mm: ST60-2 K
 Lieferbar in Stahl sowie Edelstahl A4

Übliche Formen nach DIN 6885:

Form A rundstirnig

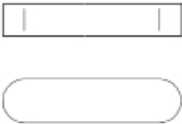

Form B geradstirnig



Form C rundstirnig
mit Bohrung

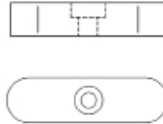

Form D geradstirnig
mit Bohrung

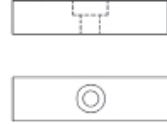

Form E rundstirnig
mit Bohrung für 2 Halteschrauben

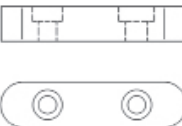

Form F geradstirnig
mit Bohrung für 2 Halteschrauben

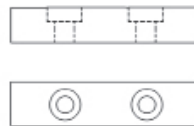



Maße in mm

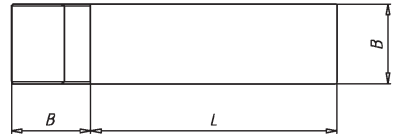
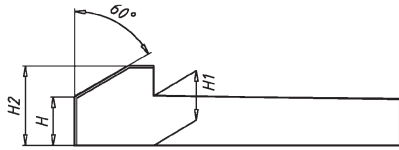

B	8	10	12	14	16	18	20	22	25
H	7	8	8	9	10	11	12	14	14
H1	7,2	8,2	8,2	9,2	10,2	11,2	12,2	14,2	14,2
H2	11	12	12	14	16	18	20	22	22

Nennmaß: BXHXL
 Neigung 1 : 100
 Keilbreite (B) = Toleranzfeld h9
 Werkstoff: ST60-1
 Lieferbar in Stahl
 Lieferbare Längen auf Anfrage

Maße in mm

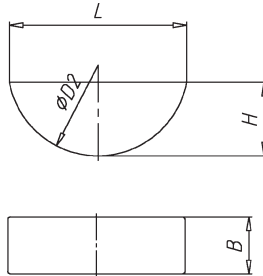

Nennmaß	B	H	L	D2	VPE
1,5x2,6	1,5	2,6	6,76	7	200
2x2,6	2	2,6	6,76	7	200
2x3,7	2	3,7	9,66	10	200
2,5x3,7	2,5	3,7	9,66	10	200
3x3,7	3	3,7	9,66	10	200
3x5	3	5	12,65	13	200
3x6,5	3	6,5	15,72	16	200
3x7,5	3	7,5	18,57	19	200
4x5	4	5	12,65	13	200
4x6,5	4	6,5	15,72	16	200
4x7,5	4	7,5	15,72	19	200
5x6,5	5	6,5	15,72	16	100
5x7,5	5	7,5	18,57	19	100
5x9	5	9	21,63	22	100
6x7,5	6	7,5	18,57	19	100
6x9	6	9	21,63	22	100
6x10	6	10	24,49	25	100
8x9	8	9	21,63	22	100
8x11	8	11	27,35	28	100
8x13	8	13	31,43	32	100
10x11	10	11	27,35	28	50
10x13	10	13	31,43	32	50
10x16	10	16	43,08	45	50

Werkstoff: ST60 Lieferbar in Stahl



Maße in mm

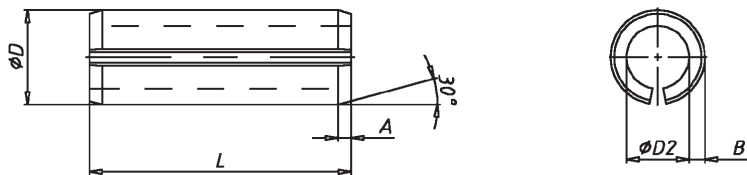

D	2	2,5	3	3,5	4	4,5	5	
D1 max ¹⁾	2,4	2,9	3,5	4	4,6	5	5,6	
D2 ²⁾	1,9	2,3	2,7	3,1	3,4	3,8	4,4	
A	0,2	0,25	0,25	0,3	0,5	0,5	0,5	
B	0,2	0,25	0,3	0,35	0,5	0,5	0,5	
D	6	8	10	12	14	16	18	20
D1 max ¹⁾	6,7	8,8	10,8	12,8	14,8	16,8	18,9	20,9
D2 ²⁾	4,9	7	8,5	10,5	11,5	13,5	15	16,5
A	0,7	1,5	2	2	2	2	2	2
B	0,75	0,75	1	1	1,5	1,5	1,75	2

Nennmesser (D) = Bohrlochdurchmesser (Passung H12)

¹⁾ D vor dem Einbau

²⁾ D2 vor dem Einbau

VPE

L \ D	2	2,5	3	4	5	6	8	10	12
4	1000	1000	1000	–	–	–	–	–	–
5	1000	1000	1000	–	–	–	–	–	–
6	1000	1000	1000	500	500	–	–	–	–
8	1000	1000	1000	500	500	–	–	–	–
10	1000	1000	1000	500	500	500	500	250	–
12	1000	1000	1000	500	500	500	500	500	–
14	1000	1000	1000	500	500	500	500	500	–
16	1000	1000	1000	500	500	500	500	500	–
18	1000	1000	1000	500	500	500	500	500	100
20	1000	1000	1000	500	500	500	500	500	100
22	1000	1000	1000	500	500	500	500	500	100
24	1000	1000	500	500	250	500	500	500	100
26	1000	1000	500	500	250	500	250	500	100
28	–	1000	500	250	250	500	250	500	100
30	1000	1000	500	250	250	500	250	500	100
32	–	–	500	250	250	500	250	500	100
36	–	–	500	250	250	500	250	500	100
40	–	–	500	250	250	250	500	250	100
45	–	–	–	250	250	250	500	250	100
50	–	–	–	250	250	250	250	250	100
55	–	–	–	–	250	250	250	–	–
60	–	–	–	–	250	250	250	100	100
70	–	–	–	–	250	250	250	100	100
80	–	–	–	–	250	250	250	100	100
90	–	–	–	–	–	–	250	100	100
100	–	–	–	–	–	–	250	100	100

Die handelsüblichen Größen sind durch Angabe der VPE gekennzeichnet.
Lieferbar in Stahl





Maße in mm

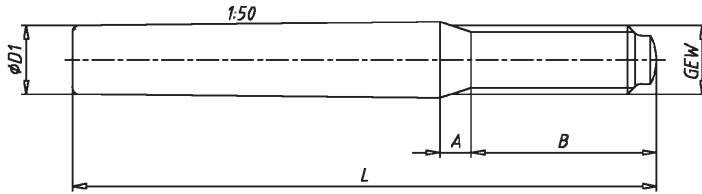

D1	5	6	8	10	12	16	20	25
A	2,4	3	4	4,5	5,3	6	6	7,5
B	14	18	22	24	27	35	35	40
GEW	M5	M6	M8	M10	M12	M16	M16	M20

VPE

L / D1	5	6	8	10	12	16	20
40	50	50	–	–	–	–	–
45	50	50	25	–	–	–	–
50	50	50	25	–	–	–	–
55	50	50	25	–	–	–	–
60	50	50	25	25	–	–	–
65	–	–	25	25	–	–	–
70	–	–	–	25	–	–	–
75	–	50	25	25	25	10	–
85	–	50	25	25	25	10	–
100	–	–	25	25	25	10	10
120	–	–	–	25	25	10	10
140	–	–	–	–	25	10	10
160	–	–	–	–	25	10	10

Die handelsüblichen Größen sind durch Angabe der VPE gekennzeichnet.
Lieferbar in Stahl



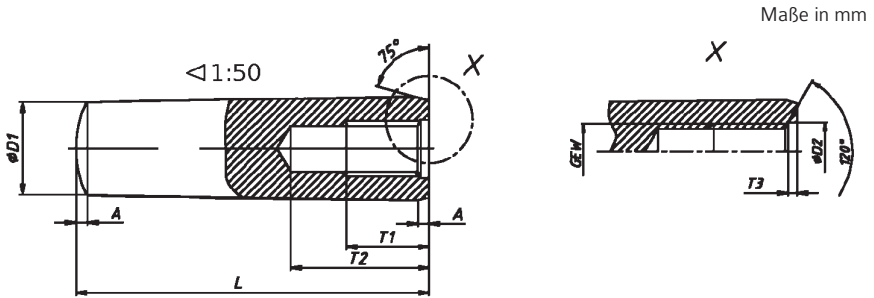

D1	6	8	10	12	16	20	25
A	0,8	1	1,2	1,6	2	2,5	3
D2	4,3	5,3	6,4	8,4	10,5	13	17
T1	6	8	10	12	16	18	24
T2	10	12	16	20	25	27	35
T3	1	1,2	1,2	1,2	1,5	1,5	1,5
GEW	M4	M5	M6	M8	M10	M12	M12

Toleranzfeld: h10

Form A: geschliffen

Werkstoff: Stahl 125 - 245 HV

VPE

L / D1	6	8	10	12	16	20
16	50	–	–	–	–	–
20	50	50	–	–	–	–
24	50	50	25	–	–	–
28	50	50	25	25	–	–
30	50	50	25	25	–	–
32	50	50	25	25	–	–
36	50	50	25	25	–	–
40	50	50	25	25	25	10
45	50	50	25	25	25	–
50	50	50	25	25	25	10
55	50	25	25	25	25	–
60	50	25	25	25	25	10
70	50	25	25	25	25	10
80	25	25	25	25	25	10
90	–	25	25	25	10	10
100	–	25	25	25	10	10
110	–	25	25	25	10	10
120	–	25	25	25	10	10
130	–	–	–	25	10	10
140	–	–	–	25	10	10
150	–	–	–	25	10	10
180	–	–	–	–	10	10

Die handelsüblichen Größen sind durch Angabe der VPE gekennzeichnet.
Lieferbar in Stahl





Maße in mm

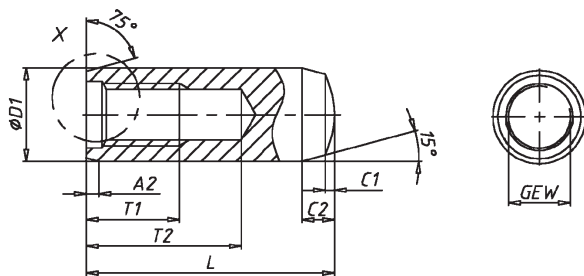

D1	6	8	10	12	14	16	20
A2	0,8	1	1,2	1,6	1,8	2	2,5
C1	0,6	0,8	1	1,2	1,4	1,6	2
C2	2,1	2,6	3	3,8	4	4,7	6
DA	4,3	5,3	6,4	6,4	8,4	8,4	10,5
GEW	M4	M5	M6	M6	M8	M8	M10
T1	6	8	10	10	12	12	16
T2	10	12	16	16	20	20	25

Toleranzfeld: m6
 Form C: ungehärtet
 Form D: gehärtet (lagerhaltig) auf 60 ± 2 HRC
 Auch nach EN ISO 8735 lieferbar.

VPE

L / D1	6	8	10	12	14	16	20
10	100	–	–	–	–	–	–
12	100	100	–	–	–	–	–
14	100	100	–	–	–	–	–
16	100	100	50	–	–	–	–
18	100	100	50	–	–	–	–
20	100	100	50	50	–	–	–
24	100	100	50	50	–	–	–
28	100	100	50	50	–	–	–
30	100	100	50	50	–	–	–
32	100	100	50	50	50	25	25
36	100	100	50	50	50	25	25
40	100	100	50	50	50	25	25
45	100	100	50	50	50	25	25
50	100	100	50	50	50	25	25
55	100	50	50	50	50	25	25
60	100	50	50	50	50	25	25
70	100	50	50	50	50	25	25
80	100	50	50	50	50	25	25
90	–	50	50	50	50	25	25
100	50	50	25	25	25	25	25
120	–	50	25	25	25	25	25
140	–	–	25	25	25	25	25
160	–	–	–	–	–	25	25

Die handelsüblichen Größen sind durch Angabe der VPE gekennzeichnet.
Lieferbar in Stahl

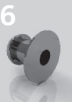



Maße in mm

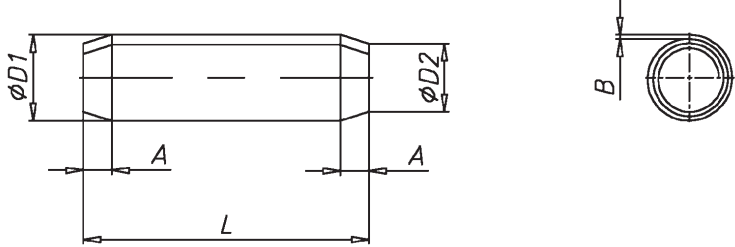

D1	1,5	2	2,5	3	4	5	6	8
A	0,5	0,7	0,7	0,9	1,1	1,3	1,5	2
B	0,17	0,22	0,28	0,33	0,45	0,56	0,67	0,9
D1 max ¹⁾	1,71	2,21	2,73	3,25	4,3	5,35	6,4	8,55
D2 ²⁾	1,4	1,9	2,4	2,9	3,9	4,85	5,85	7,8

¹⁾ D1 vor dem Einbau
²⁾ D2 vor dem Einbau

Werkstoff: Stahl, gehärtet und angelassen (420 HV - 545 HV)

VPE

L / D1	1,5	2	2,5	3	4	5	6	8
6	1000	1000	1000	1000	–	–	–	–
8	1000	1000	1000	1000	500	–	–	–
10	1000	1000	1000	1000	500	–	–	–
12	1000	1000	1000	1000	500	500	–	–
14	1000	1000	1000	1000	500	500	500	–
16	–	1000	1000	1000	500	500	500	–
18	–	1000	1000	1000	500	500	500	–
20	–	1000	1000	1000	500	500	500	–
22	–	–	–	1000	500	500	500	–
24	–	–	–	500	500	250	500	–
26	–	–	–	500	500	250	500	–
28	–	–	–	500	500	250	500	–
30	–	–	–	500	500	250	500	250
32	–	–	–	500	500	250	500	250
35	–	–	–	–	500	250	500	250
40	–	–	–	–	500	250	250	250
45	–	–	–	–	–	250	250	250
50	–	–	–	–	–	250	250	250
60	–	–	–	–	–	–	–	250

Die handelsüblichen Größen sind durch Angabe der VPE gekennzeichnet.
Lieferbar in Stahl sowie NIRO





Maße in mm

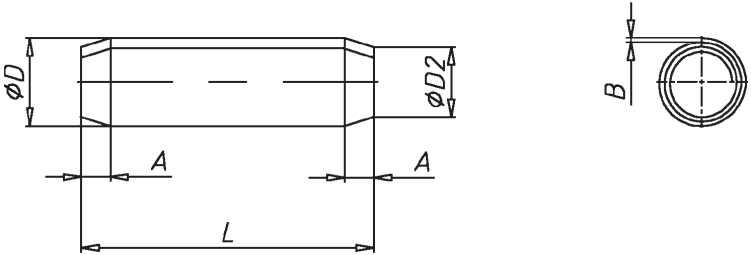

D	1	1,5	2	2,5	3	4	5	6	8	10	12	14	16
D max ¹⁾	1,15	1,73	2,25	2,78	3,3	4,4	5,5	6,5	8,63	10,8	12,85	14,95	17
D2 ²⁾	0,95	1,4	1,9	2,4	2,9	3,9	4,85	5,85	7,8	9,75	11,7	13,6	15,6
A	0,3	0,5	0,7	0,7	0,9	1,1	1,3	1,5	2	2,5	3	3,5	4
B	0,08	0,13	0,17	0,21	0,25	0,33	0,42	0,5	0,67	0,84	1	1,2	1,3
MA1 ³⁾	0,6	1,45	2,5	3,9	5,5	9,6	15	22	39	62	89	120	155
MA2 ⁴⁾	0,45	1,05	1,9	2,9	4,2	7,6	11,5	16,8	30	48	67	-	-

¹⁾ D vor dem Einbau

²⁾ D2 vor dem Einbau

³⁾ Mindestabscherkraft in kN für Spiralspannstifte aus Stahl oder martensitischem nichtrostendem Stahl

⁴⁾ Mindestabscherkraft in kN für Spiralspannstifte aus austenitischem nichtrostendem Stahl

Werkstoff: Stahl, gehärtet und angelassen (420 HV - 545 HV)

VPE

L \ D	1	1,5	2	2,5	3	4	5	6	8	10	12
4	1000	1000	1000	–	–	–	–	–	–	–	–
5	1000	1000	1000	1000	–	–	–	–	–	–	–
6	1000	1000	1000	1000	1000	–	–	–	–	–	–
8	1000	1000	1000	1000	1000	500	–	–	–	–	–
10	1000	1000	1000	1000	1000	500	500	–	–	–	–
12	–	1000	1000	1000	1000	500	500	500	–	–	–
14	–	1000	1000	1000	1000	500	500	500	–	–	–
16	–	1000	1000	1000	1000	500	500	500	500	–	–
18	–	–	1000	1000	1000	500	500	500	500	–	–
20	–	–	1000	1000	1000	500	500	500	500	500	–
22	–	–	–	1000	1000	500	500	500	500	500	–
24	–	–	–	1000	500	500	250	500	250	500	–
26	–	–	–	–	500	500	250	500	250	500	–
28	–	–	–	–	500	250	250	500	250	500	–
30	–	–	–	–	500	250	250	500	250	500	200
32	–	–	–	–	500	250	250	500	250	500	200
35	–	–	–	–	–	250	250	500	250	250	200
40	–	–	–	–	–	250	250	250	250	250	200
45	–	–	–	–	–	250	250	250	250	250	100
50	–	–	–	–	–	250	250	250	250	250	100
55	–	–	–	–	–	–	250	250	250	100	100
60	–	–	–	–	–	–	250	250	250	100	50
70	–	–	–	–	–	–	–	250	250	100	50
75	–	–	–	–	–	–	–	–	250	100	50
80	–	–	–	–	–	–	–	–	250	100	50
90	–	–	–	–	–	–	–	–	250	100	50
100	–	–	–	–	–	–	–	–	250	100	50

Die handelsüblichen Größen sind durch Angabe der VPE gekennzeichnet.
Lieferbar in Stahl sowie NIRO





Maße in mm

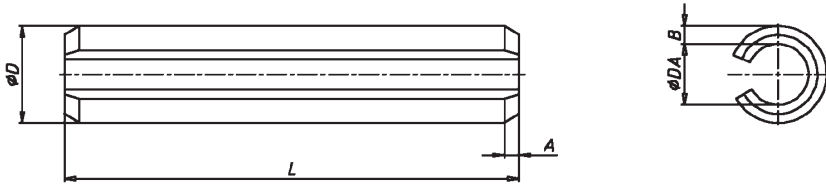

D	1	1,5	2	2,5	3	3,5	4	4,5	5	6	8	10
D max ¹⁾	1,3	1,8	2,4	2,9	3,5	4	4,6	5,1	5,6	6,7	8,8	10,8
DA ²⁾	0,8	1,1	1,5	1,8	2,1	2,3	2,8	2,9	3,4	4	5,5	6,5
A	0,35	0,45	0,55	0,6	0,7	0,8	0,85	1	1,1	1,4	2	2,4
B	0,2	0,3	0,4	0,5	0,6	0,75	0,8	1	1	1,2	1,5	2

D	12	13	14	16	18	20	21	28	30	35	40	45
D max ¹⁾	12,8	13,8	14,8	16,8	18,9	20,9	21,9	28,9	30,9	35,9	40,9	45,9
DA ²⁾	7,5	8,5	8,5	10,5	11,5	12,5	13,5	17,5	18,5	21,5	25,5	28,5
A	2,4	2,4	2,4	2,4	2,4	3,4	3,4	3,4	3,4	3,6	4,6	4
B	2,5	2,5	3	3	3,5	4	4	5,5	8	7	7,5	8,5

¹⁾ D vor dem Einbau

²⁾ DA vor dem Einbau

Werkstoff: Stahl, gehärtet und angelassen (420 HV - 545 HV)

Anwendung:

Der Durchmesser der Aufnahmebohrung muss gleich dem Nenndurchmesser D des zugehörigen Spannstiftes sein, wobei die Toleranzklasse H12 gilt.

Nach Einbau des Spannstiftes in die kleinste Aufnahmebohrung darf der Schlitz nicht vollständig geschlossen sein.

VPE

L \ D	1	1,5	2	2,5	3	3,5	4	4,5	5	6	8	10	12	13	14	16	18	20
4	1000	1000	1000	1000	1000	–	500	–	–	–	–	–	–	–	–	–	–	–
5	1000	1000	1000	1000	1000	–	500	–	500	–	–	–	–	–	–	–	–	–
6	1000	1000	1000	1000	1000	500	500	–	500	–	–	–	–	–	–	–	–	–
8	1000	1000	1000	1000	1000	500	500	500	500	–	–	–	–	–	–	–	–	–
10	1000	1000	1000	1000	1000	500	500	500	500	500	250	250	–	–	–	–	–	–
12	1000	1000	1000	1000	1000	500	500	500	500	500	250	250	–	–	–	–	–	–
14	1000	1000	1000	1000	1000	500	500	500	500	500	250	250	–	–	–	–	–	–
16	1000	1000	1000	1000	1000	500	500	500	500	500	250	250	100	–	–	–	–	–
18	1000	1000	1000	1000	1000	500	500	500	500	500	250	250	100	–	–	–	–	–
20	1000	1000	1000	1000	1000	500	500	500	500	500	250	250	100	–	–	–	–	–
22	–	–	1000	500	1000	–	500	500	500	500	250	250	100	–	–	–	–	–
24	–	–	1000	500	500	500	500	500	500	500	250	250	100	–	–	–	–	–
26	–	–	1000	500	500	500	500	500	250	500	250	250	100	50	–	–	–	–
28	–	–	1000	500	500	500	250	500	250	500	250	250	100	50	50	50	–	–
30	–	–	1000	500	500	250	250	250	250	250	250	250	100	50	50	50	–	–
32	–	–	–	–	500	250	250	250	250	250	250	250	100	50	50	50	50	–
36	–	–	–	–	500	250	250	250	250	250	250	250	100	50	50	50	50	25
40	–	–	–	–	500	250	250	250	250	250	250	250	100	50	50	50	50	25
45	–	–	–	–	500	250	250	250	250	250	250	100	100	50	50	50	50	25
50	–	–	–	–	500	250	250	250	250	250	250	100	100	50	50	50	50	25
55	–	–	–	–	–	–	250	–	250	250	250	100	100	50	50	50	50	25
60	–	–	–	–	–	–	250	–	250	250	250	100	100	50	50	50	50	25
65	–	–	–	–	–	–	–	–	250	250	250	100	100	50	50	50	50	25
70	–	–	–	–	–	–	–	–	250	250	250	100	100	50	50	50	50	25
75	–	–	–	–	–	–	–	–	250	250	250	100	100	–	–	50	50	25
80	–	–	–	–	–	–	–	–	250	250	250	100	100	50	50	50	50	25
85	–	–	–	–	–	–	–	–	–	250	100	100	100	–	–	50	50	25
90	–	–	–	–	–	–	–	–	–	250	100	100	100	50	50	50	50	25
100	–	–	–	–	–	–	–	–	–	250	100	50	50	50	50	25	25	25
120	–	–	–	–	–	–	–	–	–	–	100	50	50	50	50	25	25	25
140	–	–	–	–	–	–	–	–	–	–	–	50	50	50	50	25	25	25
160	–	–	–	–	–	–	–	–	–	–	–	–	50	50	25	25	25	25
180	–	–	–	–	–	–	–	–	–	–	–	–	50	50	25	25	25	25

Die handelsüblichen Größen sind durch Angabe der VPE gekennzeichnet.
Lieferbar in Stahl sowie NIRO





Maße in mm

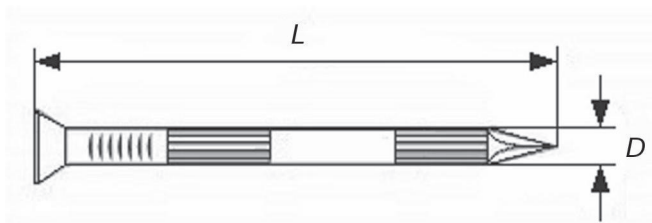

Stahlnagel, versenkter Kopf, Längsriffelung, metallisiert. Die Stahlnägel werden aus hochwertigem Stahl gefertigt. Der Nagel hat einen Senkkopf und eine unterbrochene Längsriffelung am Nagelschaft, die einen sicheren Halt im Mauerwerk gewährleisten.

VPE

L \ D	2,7	3,5	4,5	6
20	250	–	–	–
25	250	–	–	–
30	250	–	–	–
35	250	250	–	–
40	250	–	250	–
45	–	250	–	–
50	250	–	250	–
55	–	250	–	250
60	250	–	250	–
65	–	250	–	250
70	250	–	250	–
75	–	250	–	250
80	–	–	250	–
85	–	–	–	250
90	–	–	250	–
100	–	–	250	–

Die handelsüblichen Größen sind durch Angabe der VPE gekennzeichnet.
Lieferbar in Stahl

Maße in mm



Stahl, Senkkopf, glanzverzinkt, mit kombiniertem Widerhaken/Schraubgewinde für besonders hohe Auszugswerte. Geeignet für die Befestigung von Fußbodenbrettern und Spanplatten mit oft wechselnden Belastungen. Das Schraubgewinde garantiert einen sicheren Halt.

VPE

L \ D	3	3,5	4,2	4,6
20	2,5 kg	–	–	–
25	2,5 kg	–	–	–
30	2,5 kg	–	–	–
35	–	2,5 kg	–	–
40	–	2,5 kg	–	–
50	–	2,5 kg	–	–
60	–	2,5 kg	2,5 kg	–
70	–	–	2,5 kg	–
85	–	–	–	2,5 kg
100	–	–	–	2,5 kg

Die handelsüblichen Größen sind durch Angabe der VPE gekennzeichnet.
Lieferbar in Stahl



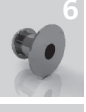



1



2



3



4



5



6



7



8



9





Maße in mm

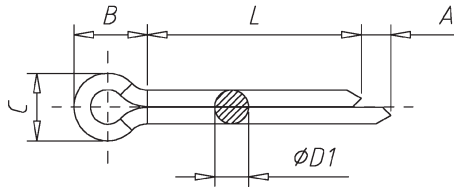

D	1	1,6	2	2,5	3,2	4	5	6,3	8	10	13	16
D1 max	0,9	1,4	1,8	2,3	2,9	3,7	4,6	5,9	7,5	9,5	12,4	15,4
A	1,6	2,5	2,5	2,5	3,2	4	4	4	4	6,3	6,3	6,3
B	3	3,2	4	5	6,4	8	10	12,6	16	20	26	32
C max	1,8	2,8	3,6	4,6	5,8	7,4	9,2	11,8	15	19	24,8	30,8

VPE

L \ D	1	1,6	2	2,5	3,2	4	5	6,3	8	10	13	16
8	1000	–	–	–	–	–	–	–	–	–	–	–
10	1000	1000	1000	–	–	–	–	–	–	–	–	–
12	1000	1000	1000	1000	500	–	–	–	–	–	–	–
16	1000	1000	1000	1000	500	–	–	–	–	–	–	–
18	1000	1000	1000	1000	500	–	–	–	–	–	–	–
20	1000	1000	1000	1000	500	500	–	–	–	–	–	–
22	1000	1000	1000	1000	500	500	250	–	–	–	–	–
25	1000	1000	1000	1000	500	500	250	–	–	–	–	–
28	1000	1000	1000	1000	500	500	250	–	–	–	–	–
32	1000	1000	1000	1000	500	500	250	250	–	–	–	–
36	–	1000	1000	1000	500	500	250	250	–	–	–	–
40	–	–	1000	1000	500	500	250	250	100	–	–	–
45	–	–	–	1000	500	500	250	250	100	–	–	–
50	–	–	–	1000	500	500	250	250	100	–	–	–
56	–	–	–	–	500	500	250	250	100	–	–	–
63	–	–	–	–	500	500	250	250	100	100	50	–
71	–	–	–	–	–	500	250	250	100	100	50	–
80	–	–	–	–	–	500	250	250	100	100	50	–
90	–	–	–	–	–	500	250	250	100	100	50	–
100	–	–	–	–	–	–	250	250	100	100	50	–
112	–	–	–	–	–	–	–	100	100	50	50	50
125	–	–	–	–	–	–	–	100	100	50	50	50
140	–	–	–	–	–	–	–	–	100	50	50	50
160	–	–	–	–	–	–	–	–	100	50	50	50
180	–	–	–	–	–	–	–	–	–	50	50	50

Die handelsüblichen Größen sind durch Angabe der VPE gekennzeichnet.
Lieferbar in Stahl sowie Edelstahl A2





Maße in mm

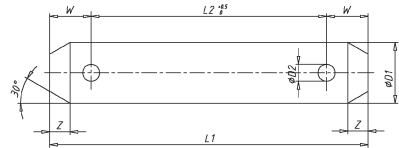
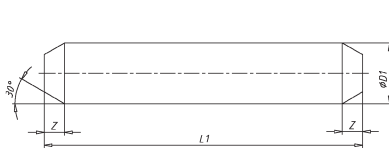

D1	3	4	5	6	8	10	12	14	16	18	20	25
D2	0,8	1	1,6	1,6	2	3,2	4	4	4	5	5	6,3
W (MIN)	1,5	1,8	2	2,5	3	4	5	5	5	6,5	6,5	8
Z	1	1	1	1,5	2	2	2,5	2,5	2,5	3	3	4

Toleranzfeld: h11

Wahlweise mit oder ohne Splintlöcher lieferbar.

Werkstoff: Automatenstahl, 125 bis 245 HV

Lieferbar in Stahl sowie NIRO

Maße in mm

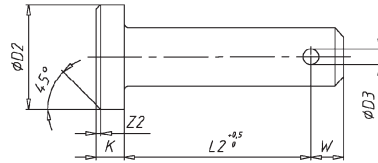
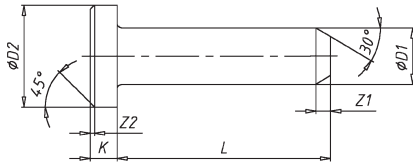

D1	3	4	5	6	8	10	12	14	16	18	20	25
D2	5	6	8	9	12	14	17	19	21	23	26	32
D3	0,8	1	1,6	1,6	2	3,2	4	4	4	5	5	6,3
K	1	1	1,5	1,5	2	2	3	3	3	3	4	5
W (MIN)	1,5	1,8	2	2,5	3	4	5	5	5	6,5	6,5	8
Z1	1,5	1,5	1,5	1,5	2	2	2,5	2,5	2,5	3	3	4
Z2	0,5	0,5	0,5	0,5	1	1	1,5	1,5	1,5	1,5	2	2

Toleranzfeld: h11

Wahlweise mit oder ohne Splintloch lieferbar.

Werkstoff: Automatenstahl, 125 bis 245 HV

Lieferbar in Stahl sowie NIRO





Maße in mm

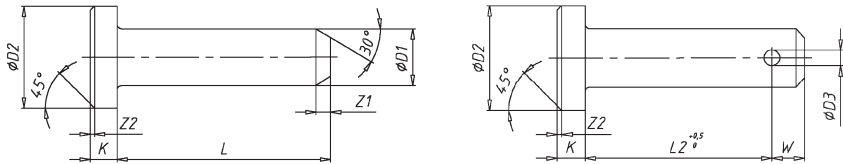

D1	5	6	8	10	12	14	16	18	20	25
D2	10	11	14	16	20	22	24	26	30	35
D3	1,6	1,6	2	3,2	4	4	4	5	5	6,3
K	3	3	4	4	5	5	5	5	6	7
W (MIN)	2	2,5	3	4	5	5	5	6,5	6,5	8
Z1	1	1,5	2	2	2,5	2,5	2,5	3	3	4
Z2	0,5	0,5	1	1	1,5	1,5	1,5	2	2	2

Toleranzfeld: h11

Wahlweise mit oder ohne Splintloch lieferbar.

Werkstoff: Automatenstahl, 125 bis 245 HV

Lieferbar in Stahl sowie NIRO

Maße in mm

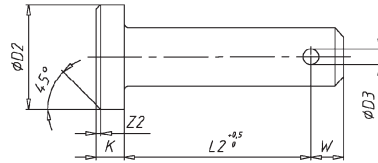
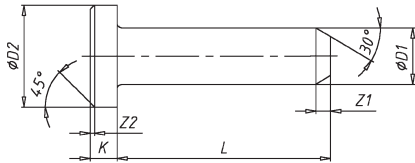

D1	6	8	10	12	14	16	18	20	25
D2	12	16	20	25	28	28	30	32	40
D3	1,6	2	3,2	4	4	4	5	5	6,3
K	3	4	4	5	5	5	5	6	7
W (MIN)	2,5	3	4	5	5	5	6,5	6,5	8
Z1	1,5	2	2	2,5	2,5	2,5	3	3	4
Z2	0,5	1	1	1,5	1,5	1,5	1,5	2	2

Toleranzfeld: h11

Wahlweise mit oder ohne Splintloch lieferbar.

Werkstoff: Automatenstahl, 125 bis 245 HV

Lieferbar in Stahl sowie NIRO





Maße in mm

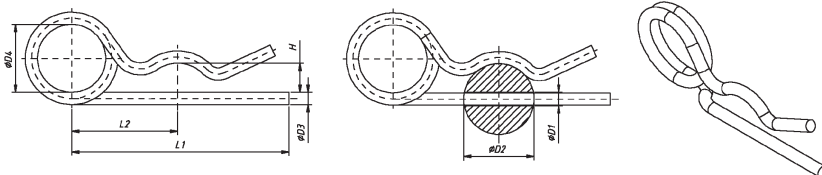

D1 ¹⁾	2,5	3,2	4	5	6,3	7	8
D2 ²⁾	9-11,2	11,2-14	14-20	20-26	26-34	34-45	45-56
D3	2,25	2,8	3,6	4,5	5,6	6,3	7
D4	20	20	20	25	25	30	30
H	2,5	3	4,5	7	9	12,5	17,5
L1	42	48	64	80	97	125	150
L2	24	26	32	39	45	56	63
VPE	50	50	50	50	25	25	25

Ausführung: Enden gratfrei geschnitten.
Lieferbar in Stahl sowie Edelstahl A2

¹⁾ Achsen- Wellen Lochdurchmesser

²⁾ Achsen- Wellen Außendurchmesser

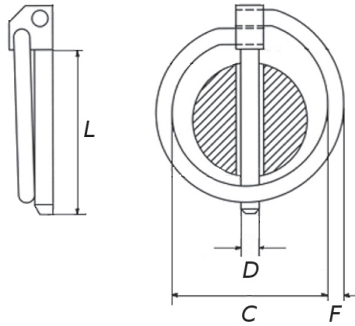

Maße in mm

Nennmaß	D	C	F	L	VPE
4,5x34	4,5	34	3	34	25
6x41	6	41	3,4	41	25
7x41	7	41	3,4	41	25
8x41	8	41	3,4	41	25
9x41	9	41	3,4	41	25
10x41	10	41	3,4	41	25
11x41	11	41	3,4	41	25
12x42	12	42	3,4	42	25

Bolzen aus ST50/ST60.

Lieferbar in Stahl sowie Edelstahl A2



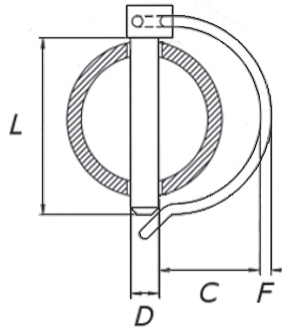

Maße in mm

Nennmaß	für Rohr-Ø	D	C	F	L	VPE
6x32	28	6	12	3 (+/- 1)	32	100
6x45	40	6	22	3 (+/- 1)	45	100
8x40	36	8	18	3 (+/- 1)	40	100
8x45	40	8	22	3 (+/- 1)	45	100
8x50	45	8	25	3 (+/- 1)	50	100
10x60	55	10	30	3 (+/- 1)	60	100

Lieferbar in Stahl sowie Edelstahl A2

Maße in mm

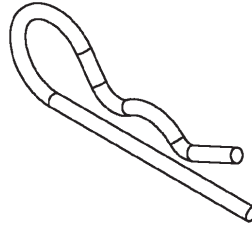
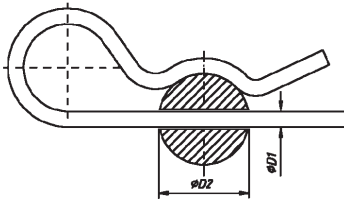

D1 ¹⁾	1,2	1,5	2	3	4	5	6	7	8
D2 ²⁾	6-9	6-10	9-14	10-16	16-20	20-28	28-40	28-45	30-45
VPE	100	100	50	50	50	25	25	25	25

Lieferbar in Stahl sowie Edelstahl A2

¹⁾ Achsen- Wellen Lochdurchmesser

²⁾ Achsen- Wellen Außendurchmesser





Maße in mm

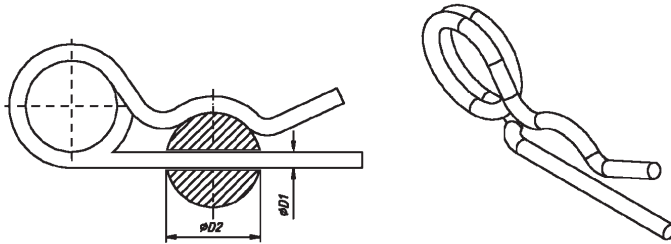

D1 ¹⁾	2	3	4	5	6	7	8
D2 ²⁾	8-14	14-20	17-24	18-30	24-36	26-40	24-40
VPE	50	50	50	25	25	10	10

Lieferbar in Stahl sowie Edelstahl A2

¹⁾ Achsen- Wellen Lochdurchmesser

²⁾ Achsen- Wellen Außendurchmesser



1



2



3



4



5



6



7



8



9





Maße in mm

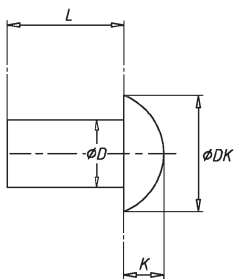

D	2	2,5	3	4	5	6	8
DK	3,5	4,4	5,2	7	8,8	10,5	14
K	1,2	1,5	1,8	2,4	3	3,6	4,8

VPE

L \ D	2	2,5	3	4	5	6	8
5	1000	1000	1000	1000	–	–	–
6	1000	1000	1000	1000	–	–	–
8	1000	1000	1000	1000	1000	–	–
10	1000	1000	1000	1000	1000	500	–
12	1000	1000	1000	1000	1000	500	250
16	1000	1000	1000	1000	1000	500	250
18	–	–	1000	1000	1000	500	250
20	–	–	1000	1000	500	500	250
22	–	–	–	1000	500	250	250
25	–	–	1000	500	500	250	250
30	–	–	–	500	500	250	250
35	–	–	–	–	250	250	100
40	–	–	–	–	250	250	100
50	–	–	–	–	250	250	100

Die handelsüblichen Größen sind durch Angabe der VPE gekennzeichnet.
 Lieferbar in Stahl, Kupfer, Aluminium, Messing sowie Edelstahl A2

Maße in mm

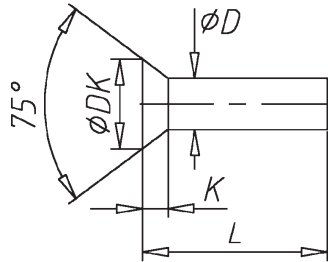

D	2	2,5	3	4	5	6	8
DK	3,5	4,4	5,2	7	8,8	10,5	14
K	1	1,2	1,4	2	2,5	3	4

VPE

L \ D	2	2,5	3	4	5	6	8
4	–	–	1000	–	–	–	–
6	1000	1000	1000	1000	–	–	–
8	1000	1000	1000	1000	1000	–	–
10	1000	1000	1000	1000	1000	500	–
12	1000	1000	1000	1000	1000	500	–
16	1000	1000	1000	1000	1000	500	250
20	–	1000	1000	1000	500	500	250
25	–	–	1000	500	500	250	250
30	–	–	–	500	500	250	250
35	–	–	–	500	250	250	100
40	–	–	–	500	250	250	100

Die handelsüblichen Größen sind durch Angabe der VPE gekennzeichnet.
Lieferbar in Stahl, Kupfer, Aluminium, Messing sowie Edelstahl A2





Maße in mm

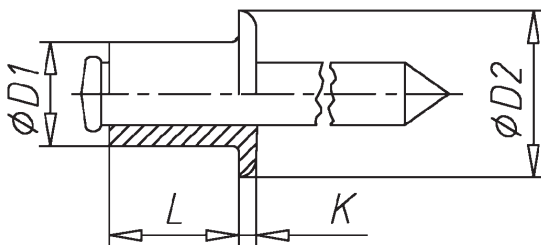

D1	2,4	3	3,2	4	4,8	5	6	6,4
D2	5	6,3	6,5	8	9,5	9,5	12	13
K	0,55	0,8	0,8	1	1,1	1,1	1,5	1,8

Teilweise auch mit großem Setzkopf lieferbar.

VPE

L \ D1	2,4	3	3,2	4	4,8	5	6	6,4
4	500	500	500	–	–	–	–	–
5	–	500	500	500	–	–	–	–
6	500	500	500	500	500	500	–	–
7	–	500	–	500	500	–	–	–
8	500	500	500	500	500	500	500	–
10	500	500	500	500	500	500	500	–
12	–	500	500	500	500	500	500	250
14	–	–	500	500	500	500	500	–
16	–	500	–	500	500	500	500	250
18	–	500	500	500	500	500	500	250
20	–	500	500	500	500	500	500	250
22	–	–	–	–	–	500	500	–
25	–	–	500	500	500	500	250	250
30	–	–	–	500	500	500	250	250
35	–	–	–	500	500	250	–	–
40	–	–	–	–	–	250	–	–

Die handelsüblichen Größen sind durch Angabe der VPE gekennzeichnet.
Lieferbar in Stahl, Aluminium sowie Edelstahl A2

Maße in mm

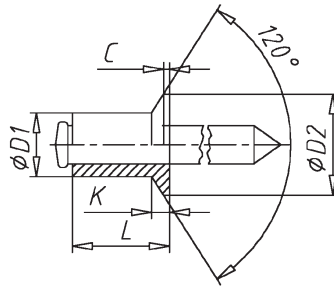

D1	3	3,2	4	4,8	5
D2	6	6,2	7,5	9	9,3
C	0,3	0,3	0,3	0,4	0,4
K	0,9	0,9	1	1,2	1,2

VPE

L \ D1	3	3,2	4	4,8	5
5	500	–	–	–	–
6	500	500	500	–	–
8	500	500	500	–	500
10	500	500	500	500	500
12	500	500	500	500	500
16	–	–	500	500	500
20	–	–	–	500	500
25	–	–	–	–	500
30	–	–	–	–	500

Die handelsüblichen Größen sind durch Angabe der VPE gekennzeichnet.
Lieferbar in Stahl, Aluminium sowie Edelstahl A2







Maße in mm

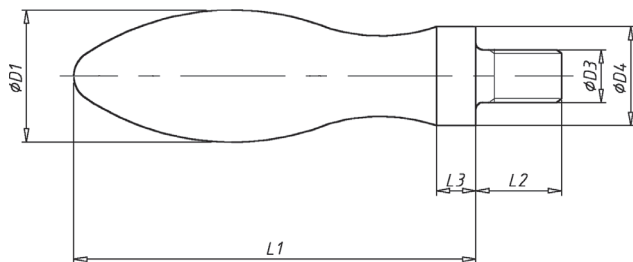

D1	10	13	16	20	25
P ¹⁾	0,7	0,8	1	1,25	1,5
D3	M4	M5	M6	M8	M10
D4	7	8	10	13	16
L1	32	40	50	64	80
L2	7	9	11	13	14
L3	4	5	7	8	10
VPE	10	10	10	10	10

Ausführung: Stahl gedreht und poliert
Auch in Form D (mit zylindrischem Zapfen) lieferbar.

Lieferbar in Stahl

¹⁾ Gewindesteigung

Maße in mm

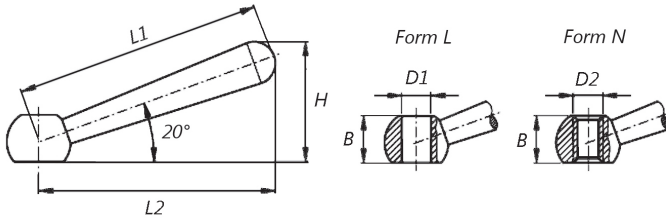

L1	50	63	80	100	125	160
L2	48	60	76	95	119	152
H	24	30,5	38	47	59,5	75,7
B	9,5	12,5	15	19	25	31
D1	6	8	10	12	16	20
D2	M6	M8	M10	M12	M16	M20
VPE	10	1	1	1	1	1

Form L: Griff schräg mit Bohrung H7

Form N: Griff schräg mit Gewinde

Lieferbar in Stahl



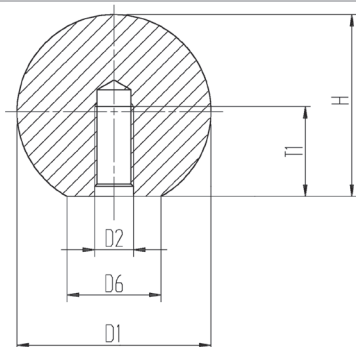

Maße in mm

Nennmaß	D1	D2	D6	H	T1	VPE
CM4D16	16	4	8	15	7,2	50
CM5D20	20	5	12	18	9,1	50
CM6D20	20	6	12	18	9,1	50
CM6D25	25	6	15	22,5	11	50
CM8D25	25	8	15	22,5	11	50
CM8D32	32	8	18	29	14,5	50
CM8D40	40	8	22	37	18	50
CM10D40	40	10	22	37	18	50
CM12D40	40	12	22	37	18	50
CM16D40	40	16	22	37	18	50

Griff: Duroplast, schwarz

Auch in Form E (Gewindebuchse) und Form M (konische Bohrung) lieferbar.

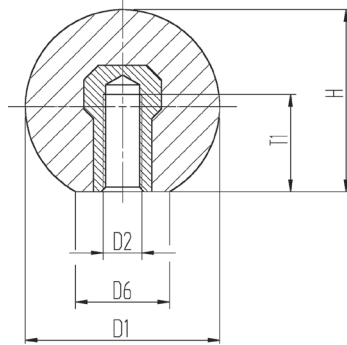

Maße in mm

Nennmaß	D1	D2	D6	H	T1	VPE
EM4D16	16	M4	8	15	6	50
EM5D20	20	M5	12	18	7,5	50
EM6D20	20	M6	12	18	7,5	50
EM6D25	25	M6	15	22,5	9	50
EM6D32	32	M6	18	29	12	50
EM8D25	25	M8	15	22,5	9	50
EM8D32	32	M8	18	29	12	50
EM8D40	40	M8	22	37	15	50
EM8D50	50	M8	27	46	18	50
EM10D40	40	M10	22	37	15	50
EM10D50	50	M10	27	46	18	50
EM12D40	40	M12	22	37	15	50
EM12D50	50	M12	27	46	18	50

Griff: Duroplast, schwarz Buchse: Stahl

Auch in Form C (Pressstoffgewinde) und Form M (konische Bohrung) lieferbar.



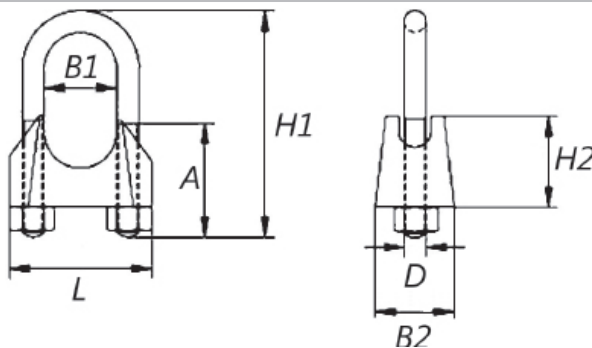

Maße in mm

Nennmaß ¹⁾	A	B1	B2	D	H1	H2	L	VPE
3	12	4	10	M4	20	10	21	100
5	13	6	11	M5	24	10	23	100
6,5	15	8	12	M5	28	11	26	100
8	19	9	14	M6	34	15	30	50
10	22	11	18	M8	42	17	34	50
11	22	12	19	M8	44	18	36	50
13	30	14	23	M10	55	21	42	50
14	30	15	23	M10	57	22	44	25
16	33	17	26	M12	63	26	50	10
19	38	20	29	M12	75	30	54	10
22	44	23	33	M14	85	34	61	10
26	45	27	35	M14	95	37	65	10
30	50	32	37	M16	110	43	74	10

Seilklemmen für untergeordnete Zwecke. Die angegebenen Maße können herstellungsbedingt abweichen.
Lieferbar in Stahl

¹⁾ größter Seildurchmesser

Maße in mm

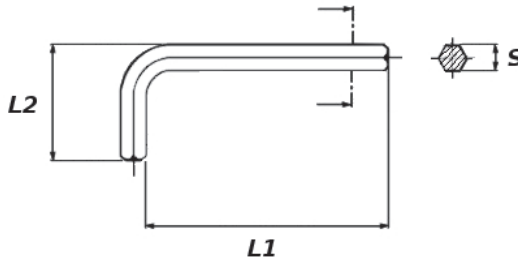

S	1,5	2	2,5	3	4	5	6	8	10
L1	45	50	56	63	72	80	90	100	112
L2	14	16	18	20	25	28	32	36	40
Passend für DIN 912	M2	M2,5	M3	M4	M5	M6	M8	M10	M12
VPE	1	1	1	1	1	1	1	1	1
S	12	14	17	19	22	24	27	32	36
L1	125	140	160	180	200	224	250	315	355
L2	45	56	63	70	80	90	100	125	140
Passend für DIN 912	M14	M16	M20	M24	M30	M33	M36	M42	M48
VPE	1	1	1	1	1	1	1	1	1

Lieferbar in Stahl



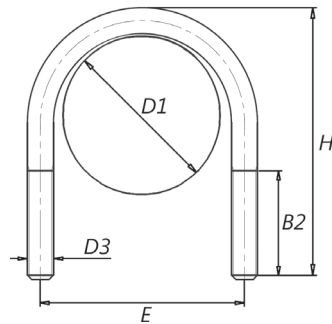

Maße in mm

Nennmaß	B2	D1 ¹⁾	D3	E	H	VPE
NW15 M10	30	18	M10	33	67	50
NW20 M10	40	25-26,9	M10	40	70	50
NW25 M10	40	30-33,7	M10	48	76	50
NW32 M10	50	38-42,4	M10	56	86	50
NW40 M10	50	44,5-48,3	M10	62	92	50
NW50 M12	50	57-60,3	M12	76	109	50
NW65 M12	50	76,1	M12	94	125	50
NW80 M12	50	88,9	M12	106	138	50
NW100 M16	60	108,0-114,3	M16	136	171	25
NW125 M16	60	133,0-139,7	M16	164	191	25
NW150 M16	60	159,0-168,3	M16	192	217	25
NW200 M20	70	216,0-219,1	M20	248	283	25
NW250 M20	70	267,0-273,0	M20	302	334	1
NW300 M20	70	318,0-332,9	M20	352	385	1
NW350 M24	70	355,6-368,0	M24	402	435	1

Dünnschaft, Gewinde gerollt

Lieferbar in Stahl sowie Edelstahl A2

¹⁾ Rohrdurchmesser

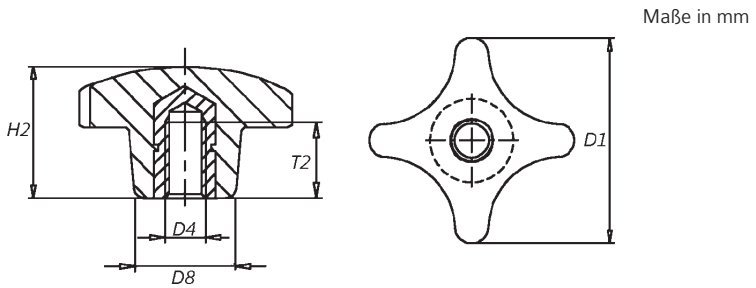

NENN	D1	D4	D8	H2	T2	D8	VPE
M5D25	25	M5	12	16	9,5	12	10
M6D32	32	M6	14	20	12	14	10
M8D40	40	M8	18	25	14	18	10
M10D50	50	M10	22	32	18	22	10
M12D63	63	M12	26	40	22	26	100
M16D80	80	M16	35	50	30	35	10

Griff: Duroplast, schwarz Buchse: Stahl, verzinkt
 Temperatureinsatzbereich bis max. 110 °C.

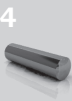



Maße in mm

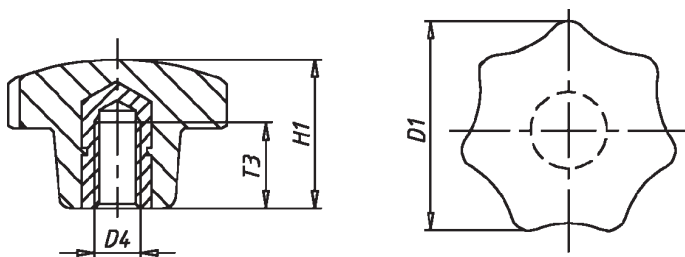

Nennmaß	D1	D4	H1	T3	VPE
M4D20	20	M4	13	6,5	1
M5D25	25	M5	16	9,5	1
M6D32	32	M6	20	12	1
M8D40	40	M8	25	14	1
M10D50	50	M10	32	18	1
M12D63	63	M12	40	22	1
M16D80	80	M16	50	30	1

Griff: Duroplast, schwarz Buchse: Stahl, verzinkt

Maße in mm

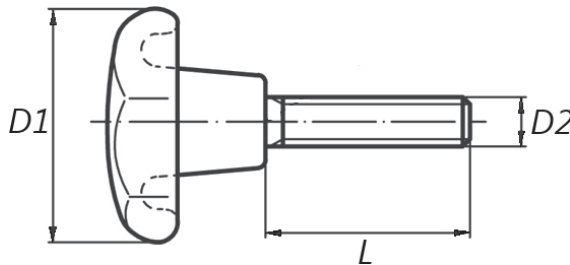

NENN	D1	D2	L	VPE
5x30D32	32	M5	30	1
6x10D40	40	M6	40	1
6x12D32	32	M6	32	1
6x16D32	32	M6	16	1
6x20D32	32	M6	20	1
6x20D40	40	M6	20	1
6x25D32	32	M6	25	1
6x25D40	40	M6	25	1
6x30D32	32	M6	30	1
6x30D40	40	M6	30	1
6x40D32	32	M6	40	1
8x15D40	40	M8	15	1
8x20D32	32	M8	20	1
8x20D40	40	M8	20	1
8x25D40	40	M8	25	1
8x30D32	32	M8	30	1
8x30D40	40	M8	30	1
8x30D50	50	M8	30	1
8x40D40	40	M8	40	1

NENN	D1	D2	L	VPE
8x50D40	40	M8	50	1
8x50D50	50	M8	50	1
10x15D63	63	M10	15	1
10x20D40	40	M10	20	1
10x20D63	63	M10	20	1
10x30D40	40	M10	30	1
10x30D50	50	M10	30	1
10x30D63	63	M10	30	1
10x40D50	50	M10	40	1
10x40D63	63	M10	40	1
10x50D50	50	M10	50	1
10x50D63	63	M10	50	1
10x60D40	40	M10	60	1
10x60D50	60	M10	60	1
10x65D63	63	M10	65	1
10x70D63	63	M10	70	1
12x30D63	63	M12	30	1
12x40D63	63	M12	40	1
12x60D63	63	M12	60	1

Griff: Duroplast, schwarz Bolzen: Stahl, verzinkt

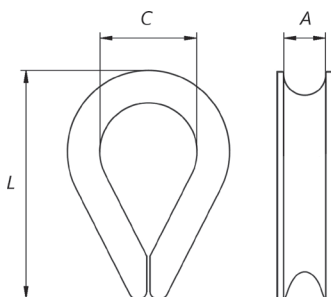

Maße in mm

Nennmaß ¹⁾	A	C	L	VPE
A2,5	3	10	21,5	100
A3	3,5	11	23,5	100
A3,5	4	12	26,5	100
A4	5	13	28,5	100
A5	6	14	30	100
A6	7	15	33	100
A7	8	16	35	100
A8	9	18	39	100
A10	11	22	47,5	100
A12	13	26	56,5	50
A16	18	35	78	50

Die angegebenen Maße können herstellungsbedingt abweichen.

Lieferbar in Stahl sowie Edelstahl A2

¹⁾ Seildurchmesser

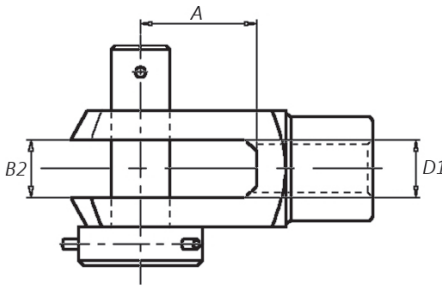

Maße in mm

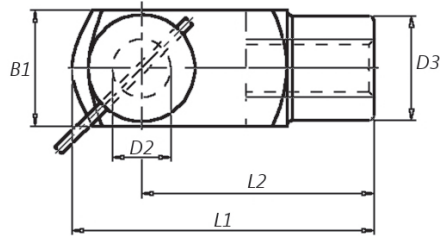

Nennmaß	A	B1	B2	D1	D2	D3	L1	L2	VPE
A4x8	8	8	4	M4	4	8	21	16	50
A4x16	16	8	4	M4	4	8	29	24	50
A5x10	10	10	5	M5	5	9	26	20	50
A5x20	20	10	5	M5	5	9	36	30	50
A6x12	12	12	6	M6	6	10	31	24	50
A6x24	24	12	6	M6	6	10	43	36	50
A8x16	16	16	8	M8	8	14	42	32	1
A8x32	32	16	8	M8	8	14	58	48	1
A10x20	20	20	10	M10	10	18	52	40	1
A10x40	40	20	10	M10	10	18	72	60	1
A12x24	24	24	12	M12	12	20	62	48	1
A12x48	48	24	12	M12	12	20	86	72	1
A16x32	32	32	16	M16	16	26	83	64	1
A16x64	64	32	16	M16	16	26	115	96	1
A20x40	40	40	20	M20	20	34	105	80	1
A25x50	50	50	25	M25x3	25	42	132	100	1
A30x60	60	60	30	M30x3,5	30	52	160	120	1

Auch lieferbar in Form B (mit ES-Bolzen) oder Form S (mit Schnappfederbolzen).
Lieferbar in Stahl



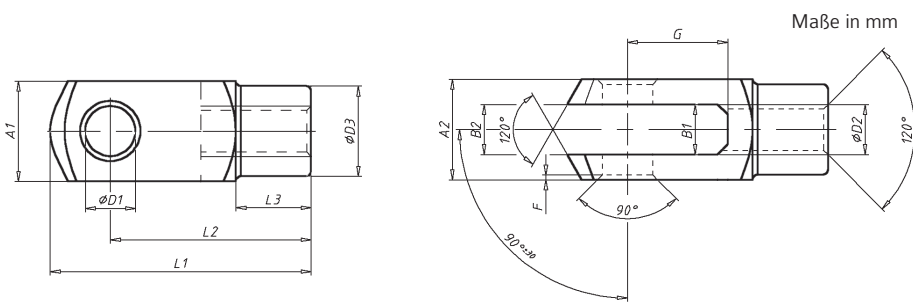

Maße in mm

Nennmaß	A1	A2	B1	B2	D1	D2	D3	F	G	L1	L2	L3	VPE
G4x8	8	8	4	4	4	M4	8	0,5	8	21	16	6	1
G5x10	10	10	5	5	5	M5	9	0,5	10	26	20	7,5	1
G5x20	10	10	5	5	5	M5	9	0,5	20	36	30	7,5	1
G6x12	12	12	6	6	6	M6	10	0,5	12	31	24	9	1
G6x24	12	12	6	6	6	M6	10	0,5	24	43	36	9	1
G8x16	16	16	8	8	8	M8	14	0,5	16	42	32	12	1
G8x32	16	16	8	8	8	M8	14	0,5	32	58	48	12	1
G10x20	20	20	10	10	10	M10	18	0,5	20	52	40	15	1
G10x40	20	20	10	10	10	M10	18	0,5	40	72	60	15	1
G12x24	24	24	12	12	12	M12	20	0,5	24	62	48	18	1
G12x48	24	24	12	12	12	M12	20	0,5	48	86	72	18	1
G14x28	27	27	14	14	14	M14	24	1	28	72	56	22,5	1
G16x32	32	32	16	16	16	M16	26	1	32	83	64	24	1
G16x64	32	32	16	16	16	M16	26	1	64	115	96	24	1
G20x40	40	40	20	20	20	M20	34	1	40	105	80	30	1

Passender Federklappbolzen siehe N0365.
Lieferbar in Stahl und Edelstahl

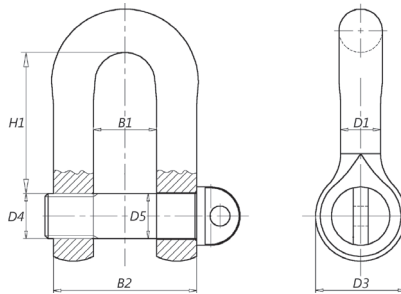

Maße in mm



Nennmaß ¹⁾	B1	B2	H1	D1	D4	D5	VPE
0,1	7	15	15,5	4	M5	5	50
0,16	8	18	18	5	M6	6	50
0,25	11	25	24	7	M8	8	50
0,4	14	30	30	8	M10	10	25
0,6	17	37	36	10	M12	12	25
1	21	47	49	13	M16	16	10
1,6	27	61	61	17	M20	20	5
2	30	68	67	19	M22	22	5
2,5	33	75	73	21	M24	24	1
3	38	86	83,5	24	M27	27	1
4	42	96	91	27	M30	30	1
5	47	107	111	30	M36	36	1
6	53	121	119,5	34	M39	39	1
8	60	136	139,5	38	M45	45	1
10	66	150	147	42	M48	48	1
12	73	167	158	47	M52	52	1
16	81	185	185	52	M60	60	1
20	90	206	211	58	M68	68	1
25	100	226	221	63	M72	72	1

Lieferbar in Stahl

¹⁾ Nutzlast in t



Maße in mm

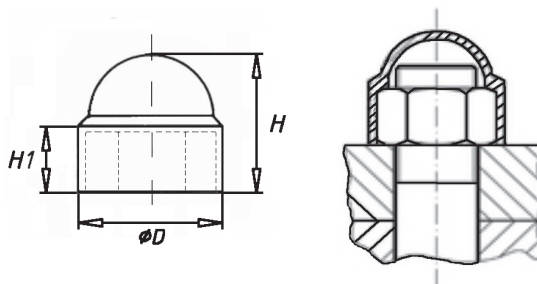

M ¹⁾	M4	M5	M6	M8	M10	M12
SW ²⁾	7	8	10	13	17	19
D	9	10,9	12,9	16,8	21,3	23,6
H	8,3	9,5	13	15	19,5	21,5
H1	3,5	5	6	7,5	9	11
VPE	100	100	100	100	100	100

M ¹⁾	M14	M16	M20	M24	M27	M30	M36
SW ²⁾	21	24	30	36	41	46	55
D	27	29,8	37,4	43,6	50	56,4	65,8
H	23,5	27	33,2	39,3	48	50,5	57,6
H1	12,2	14	17	22,7	25	27,6	32,3
VPE	100	50	50	50	50	50	50

Bei nicht genormten Teilen können die angegebenen Maße herstellungsbedingt abweichen.
 Lieferbar in Polyethylen in den Farben weiß, grau und schwarz.

¹⁾ geeignet für Schraube DIN 933

²⁾ Schlüsselweite

Maße in mm

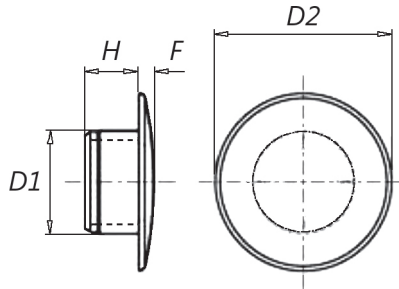

SW ¹⁾	3	4	5	6	8	10	12	14	17
M ²⁾	M4	M5	M6	M8	M10	M12	M14	M16	M20
D1	3,2	4,2	5,2	6,2	8,2	10,3	13,2	14,3	17,4
D2	9	9	10	13	16	18	17,5	24	30
H	2,2	2,5	3,1	4,0	5,0	6,4	8,3	7,0	9,0
F	1,4	1,3	1,4	1,5	1,6	1,8	1,6	2,2	2,5
VPE	100	100	100	100	100	100	100	100	100

Zur schnellen und sauberen Abdeckung des Innensechskants, zum Schutz vor Staub und Schmutz.

Temperatureinsatzbereich: -40°C bis +65°C

Lieferbar in Polyethylen (LD-PR) in den Farben schwarz (RAL9005), weiß (RAL9003), grau (RAL7000)

¹⁾ Schlüsselweite

²⁾ passend für DIN 912





Maße in mm

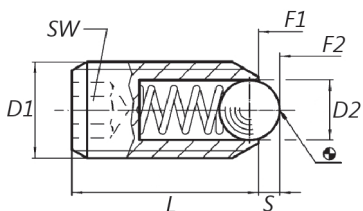

Nennmaß	D1	D2	F1 ¹⁾	F2 ²⁾	L	S	SW	VPE
KM 3	M3	1,5	3	4,5	8	0,4	1,5	25
KM 4	M4	2,5	8,5	14	12	0,8	2	25
KM 5	M5	3	8	14	14	0,9	2,5	25
KM 6	M6	3,5	11	18	15	1	3	25
KM 8	M8	4,5	18	31	18	1,5	4	25
KM 10	M10	6	24	45	23	2	5	25
KM 12	M12	8	26	49	26	2,5	6	10
KM 16	M16	10	41	86	33	3,5	8	10
KM 20	M20	12	56	111	43	4,5	10	5

Zur Arretierung sowie als An- und Abdruckstift.
Temperatureinsatzbereich bis max. 250°C. .

Werkstoff:

Hülse:

- Automatenstahl, brüniert
- Rostfreier Stahl 1.4305

Kugel:

- Kugellagerstahl, gehärtet
- Rostfreier Stahl, gehärtet

Feder:

- Rostfreier Stahl

Bei nicht genormten Teilen können die angegebenen Maße herstellungsbedingt abweichen.

¹⁾ Federkraft (Anfang) N~

²⁾ Federkraft (Ende) N~

Maße in mm

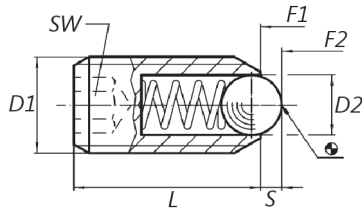

Nennmaß	D1	D2	F1 ¹⁾	F2 ²⁾	L	S	SW	VPE
KSM 5	M5	3	15	22	14	0,9	2,5	25
KSM 6	M6	3,5	19	28	15	1	3	25
KSM 8	M8	4,5	36	62	18	1,5	4	25
KSM 10	M10	6	57	104	23	2	5	25
KSM 12	M12	8	61	110	26	2,5	6	10
KSM 16	M16	10	68	142	33	3,5	8	10
KSM 20	M20	12	84	166	43	4,5	10	5

Zur Arretierung sowie als An- und Abdrückstift.

Temperatureinsatzbereich bis max. 250°C.

Werkstoff:

Hülse:

- Automatenstahl, brüniert
- Rostfreier Stahl 1.4305

Kugel:

- Kugellagerstahl, gehärtet
- Rostfreier Stahl, gehärtet

Feder:

- Rostfreier Stahl

Bei nicht genormten Teilen können die angegebenen Maße herstellungsbedingt abweichen.

¹⁾ Federkraft (Anfang) N~

²⁾ Federkraft (Ende) N~



Maße in mm

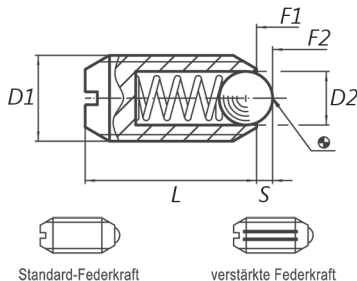

Nennmaß	D1	D2	F1 ¹⁾	F2 ²⁾	L	S	VPE
KM 3	M3	1,5	3	4,5	7	0,4	50
KM 4	M4	2,5	8,5	14	9	0,8	50
KM 5	M5	3	8	14	12	0,9	50
KM 6	M6	3,5	11	18	14	1	50
KM 8	M8	4,5	18	31	16	1,5	50
KM 10	M10	6	24	45	19	2	50
KM 12	M12	8	26	49	22	2,5	25
KM 16	M16	10	41	86	24	3,5	25
KM 20	M20	12	56	111	30	4,5	10
KM 24	M24	15	81	151	34	5,5	5

Hinweis: Zur Arretierung sowie als An- und Abdrückstift.
Temperatureinsatzbereich bis max. 250 °C.

Werkstoff:

Hülse:

- Automatenstahl, brüniert
- Rostfreier Stahl 1.4305

Kugel:

- Kugellagerstahl, gehärtet
- Rostfreier Stahl, gehärtet

Feder:

- Rostfreier Stahl

Kennzeichnung:

Ausführung Standard-Federkraft = keine Markierung.

Ausführung verstärkte Federkraft = 2 Längsmarkierungen.

¹⁾ Federkraft (Anfang) N~

²⁾ Federkraft (Ende) N~

Maße in mm

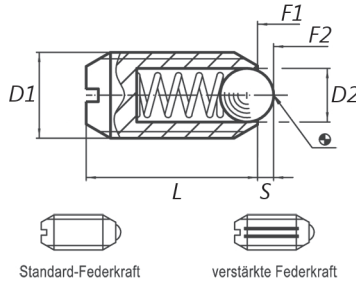

Nennmaß	D1	D2	F1 ¹⁾	F2 ²⁾	L	S	VPE
KSM 5	M5	3	15	22	12	0,9	50
KSM 6	M6	3,5	19	28	14	1	50
KSM 8	M8	4,5	36	62	16	1,5	50
KSM 10	M10	6	57	104	19	2	25
KSM 12	M12	8	61	110	22	2,5	25
KSM 16	M16	10	68	142	24	3,5	10
KSM 20	M20	12	84	166	30	4,5	10
KSM 24	M24	15	127	237	34	5,5	5

Hinweis: Zur Arretierung sowie als An- und Abdruckstift.
 Temperatureinsatzbereich bis max. 250 °C.

Werkstoff:

Hülse:

- Automatenstahl, brüniert
- Rostfreier Stahl 1.4305

Kugel:

- Kugellagerstahl, gehärtet
- Rostfreier Stahl, gehärtet

Feder:

- Rostfreier Stahl

Kennzeichnung:

- Ausführung Standard-Federkraft = keine Markierung.
- Ausführung verstärkte Federkraft = 2 Längsmarkierungen.

¹⁾ Federkraft (Anfang) N~

²⁾ Federkraft (Ende) N~



Maße in mm

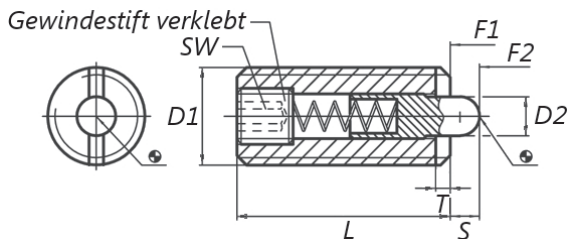

Nennmaß	D1	D2	F1 ¹⁾	F2 ²⁾	L	S	SW	VPE
AM 3	M3	1	2	4	12	1	0,7	25
AM 4	M4	1,5	4,5	16	15	1,5	1,3	25
AM 5	M5	2,4	6	19	18	2,3	1,5	25
AM 6	M6	2,7	6	19	20	2,5	2	25
AM 8	M8	3,5	10	39	22	3	2,5	10
AM 10	M10	4	10	39	22	3	3	10
AM 12	M12	6	12	53	28	4	4	10
AM 16	M16	7,5	45	100	32	5	5	10
AM 20	M20	10	52	125	40	7	6	5

Hinweis:

Zur Arretierung sowie als An- und Abdrückstift.
Montage / Demontage mit Innensechskant und Schlitz möglich.

Werkstoff:

Hülse:

- Automatenstahl, brüniert
- Rostfreier Stahl 1.4305

Bolzen:

- Automatenstahl, gehärtet, brüniert
- Rostfreier Stahl 1.4305
- Thermoplast POM, weiß

Feder:

- Rostfreier Stahl

Kennzeichnung:

Ausführung Standard-Federkraft = keine Markierung.

Ausführung verstärkte Federkraft = 2 Längsmarkierungen.

¹⁾ Federkraft (Anfang) N~

²⁾ Federkraft (Ende) N~

Maße in mm

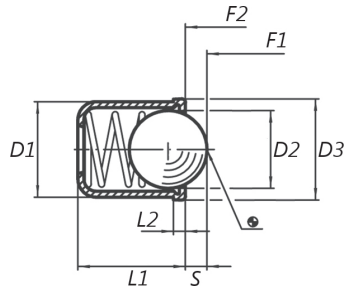

Nennmaß	D1	D2	D3	F1 ¹⁾	F2 ²⁾	L1	L2	S	VPE
N3	3	2,38	3,5	1,8	3,5	4	0,75	0,7	50
N4	4	3	4,6	2,5	6	5	0,9	1	50
N5	5	4	5,6	3	6,5	6	0,9	1,4	50
N6	6	5	6,5	5,5	11,5	7	1	1,8	50
N8	8	6,5	8,5	7	12,5	9	1,1	2,4	50
N10	10	8,5	11	8,5	18,5	13	1,5	3,3	25
N12	12	10	13	12	26,5	16	2,3	4	10

Hülse: Nirosta 1.4303 Kugel: Nirosta, gehärtet Feder: Nirosta

¹⁾ Federkraft (Anfang) N~

²⁾ Federkraft (Ende) N~





Maße in mm

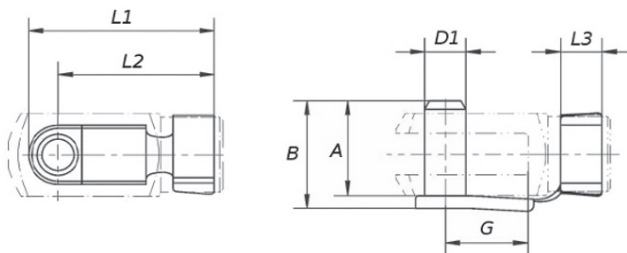

Nennmaß	A	B	G	D1	L1	L2	L3	VPE
FKB 4X8	9,5	11	8	4	19	15	4,5	10
FKB 5X10	12	13,5	10	5	23	19	5,5	10
FKB 5X20	12	13,5	20	5	33	29	5,5	10
FKB 6X12	14	16	12	6	28	23	6,5	10
FKB 6X24	14	16	24	6	40	35	6,5	10
FKB 8X16	19	21,5	16	8	37	30	8	10
FKB 8X32	19	21,5	32	8	52	46	8	10
FKB 10X20	23	26	20	10	46	38	10	10
FKB 10X40	23	26	40	10	66	58	10	10
FKB 12X24	28	31	24	12	53	45	12	10
FKB 12X48	28	31	48	12	78	69	12	10
FKB 14X28	31	34	28	14	62	52	14	10
FKB 14X56	31	34	56	14	92	82	14	10
FKB 16X32	36	39	32	16	73	62	16	5
FKB 16X64	36	39	64	16	103	92	16	5
FKB 20X40	45	50	40	20	87,5	71,5	19	5

Werkstoff Bolzen: 1.0718 Zugfestigkeit ca. 550 - 700 N/mm²

Werkstoff Feder: C60 bis Ck75 gehärtet und angelassen auf ca. 430-500 HV

Maße in mm

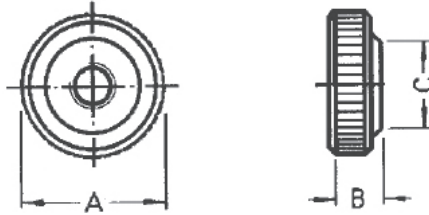

Nennmaß ¹⁾	M3	M4	M5	M6X19	M6X26	M8
A	9,5	13	16	19	26	26
B	4,5	5,5	6,5	7,5	7,8	9,8
C	8,3	9,8	11,5	13	13	16
VPE	100	100	100	100	100	100

Lieferbar in Kunststoff rot, grau und schwarz.

¹⁾ geeignet für Schraube DIN 912





Maße in mm

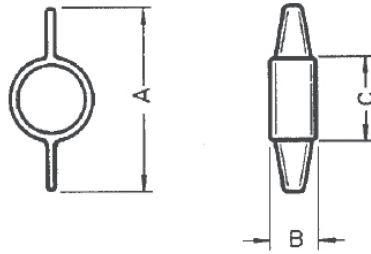

Nennmaß ¹⁾	M5	M6	M8	M10
A	26	30	38	45
B	6,6	7,8	10	12,5
C	12	13,5	16,5	20
VPE	100	100	100	100

Lieferbar in Kunststoff rot, grau und schwarz.
¹⁾ geeignet für Schraube DIN 912

Maße in mm

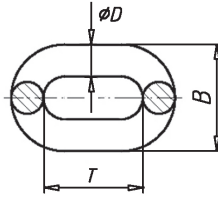

Nennmaß	B	D	T	Tragkraft max. in kg	VPE
A3	12	3	16	45	60
A4	16	4	19	80	30
A5	20	5	21	125	30
A6	24	6	24	160	30
A8	32	8	32	320	10
A10	40	10	40	500	10
C2	8	2	22	20	60
C3	12	3	26	45	60
C4	16	4	32	80	30
C5	20	5	36	125	30
C6	24	6	42	160	30
C8	32	8	52	320	10
C10	40	10	65	500	10

Angaben über Belastungen sind unverbindlich! Ketten nach DIN 5685 sind nicht auf Festigkeit im Sinne von DIN 685 Teil 3 geprüft und dürfen nicht als Aufnahmemittel oder Tragmittel im Sinne von DIN 15003, sowie nicht zum statischen Aufhängen von Lasten benutzt werden.

Werkstoff: Stahl, ohne Güteanforderung.

VPE in Meter. Verkauf erfolgt nur in ganzen VPE.

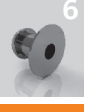





Maße in mm

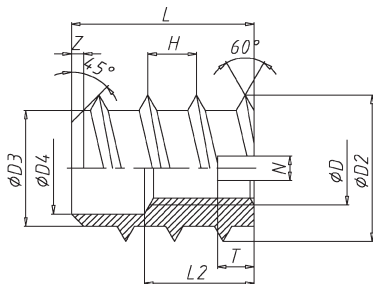

D	M3	M4	M5	M6	M8	M10	M12
D2	6	8	10	12	16	18,5	22
D3	4,5	5,5	7,5	9,5	12,5	15	18
D4	3,5	4,5	6	7,5	10	12	15
H	2	2,5	3,5	4	5	5	5
L2	5	6	7	9	11	13	16
N	1	1,2	1,6	2	2,5	3	3
Z	0,6	0,6	0,8	1	1	1,6	1,6

Einschraubmuttern sind vorzugsweise zum Einschrauben in Holz geeignet.

VPE

L \ D	M3	M4	M5	M6	M8	M10	M12
8	200	200	–	–	–	–	–
10	200	200	200	200	–	–	–
12	200	200	200	200	–	–	–
14	–	–	–	–	100	–	–
15	–	200	200	200	100	100	–
18	–	–	200	200	100	–	–
20	–	–	200	200	–	100	100
23	–	–	–	–	100	–	–
25	–	–	–	200	–	100	–
30	–	–	–	–	100	100	100

Die handelsüblichen Größen sind durch Angabe der VPE gekennzeichnet.
Lieferbar in Stahl und Messing





Maße in mm

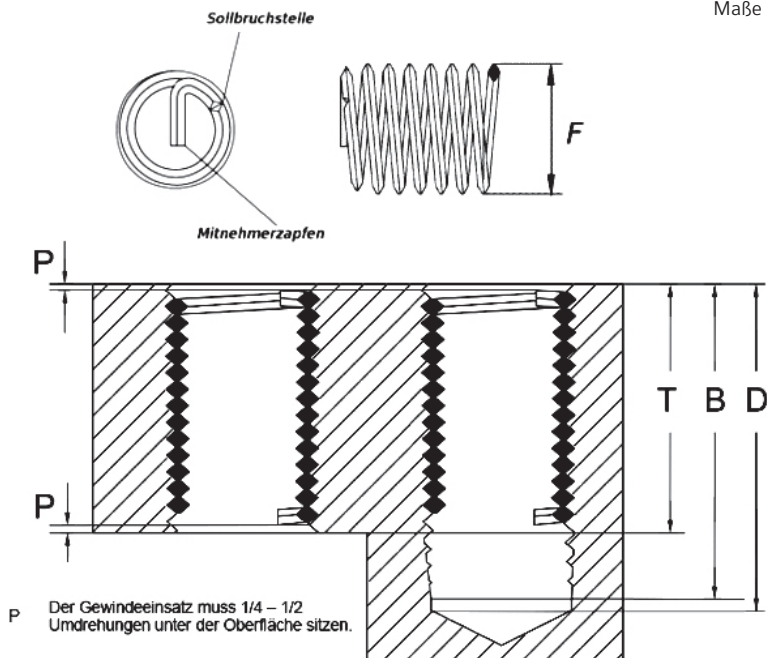

Nennmaß	F max. ¹⁾	B Ø ²⁾	T ³⁾	D ⁴⁾	B ⁵⁾	VPE
M2X2	2,80	2,1	2,00	3,80	3,40	100
M2X4	2,80	2,1	4,00	5,80	5,40	100
M2X6	2,80	2,1	6,00	7,80	7,40	100
M2,5X2,5	3,70	2,6	2,50	4,52	4,07	100
M2,5X3,75	3,70	2,6	3,75	5,78	5,33	100
M2,5X5	3,70	2,6	5,00	7,03	6,58	100
M2,5X7,5	3,70	2,6	7,50	9,53	9,08	100
M3x3	4,35	3,2	3,00	5,25	4,75	100
M3x4,5	4,35	3,2	4,50	6,75	6,25	100
M3x6	4,35	3,2	6,00	8,25	7,75	100
M3X7,5	4,35	3,2	7,50	9,75	9,25	100
M3X9	4,35	3,2	9,00	11,25	10,75	100
M3,5X7	4,75	3,7	7,00	9,70	9,10	50
M4x4	5,60	4,2	4,00	7,15	6,45	100

Nennmaß	F max. ¹⁾	B Ø ²⁾	T ³⁾	D ⁴⁾	B ⁵⁾	VPE
M4x6	5,60	4,2	6,00	9,15	8,45	100
M4x8	5,60	4,2	8,00	11,15	10,45	100
M4x10	5,60	4,2	10,00	13,15	12,45	100
M4x12	5,60	4,2	12,00	15,15	14,45	100
M5x5	6,80	5,2	5,00	8,60	7,80	100
M5x7,5	6,80	5,2	7,50	11,10	10,30	100
M5x10	6,80	5,2	10,00	13,60	12,80	100
M5x12,5	6,80	5,2	12,50	16,10	15,30	100
M5x15	6,80	5,2	15,00	18,60	17,80	100
M6x6	7,95	6,3	6,00	10,50	9,50	100
M6x9	7,95	6,3	9,00	13,50	12,50	100
M6x12	7,95	6,3	12,00	16,50	15,50	100
M6x15	7,95	6,3	15,00	19,50	18,50	100
M6x18	7,95	6,3	18,00	22,50	21,50	100
M7x7	9,20	7,3	7,00	11,50	10,50	100
M7x10,5	9,20	7,3	10,50	15,00	14,00	100
M7x14	9,20	7,3	14,00	18,50	17,50	100
M8x8	10,35	8,4	8,00	13,63	12,38	100
M8x12	10,35	8,4	12,00	17,63	16,38	100
M8x16	10,35	8,4	16,00	21,63	20,38	100
M8x20	10,35	8,4	20,00	25,63	24,38	100
M8x24	10,35	8,4	24,00	29,63	28,38	100
M10x10	12,50	10,5	10,00	16,75	15,25	100
M10x15	12,50	10,5	15,00	21,75	20,25	100
M10x20	12,50	10,5	20,00	26,75	25,25	100
M10x25	12,50	10,5	25,00	31,75	30,25	100
M10x30	12,50	10,5	30,00	36,75	35,25	100
M12x12	15,00	12,5	12,00	19,88	18,13	100
M12x18	15,00	12,5	18,00	25,88	24,13	100
M12x24	15,00	12,5	24,00	31,88	30,13	100
M12X30	15,00	12,5	30,00	37,88	36,13	100
M12X36	15,00	12,5	36,00	43,88	42,13	100





Nennmaß	F max. ¹⁾	B Ø ²⁾	T ³⁾	D ⁴⁾	B ⁵⁾	VPE
M14x14	17,35	14,5	14,00	23,00	21,00	50
M14x21	17,35	14,5	21,00	30,00	28,00	50
M14x28	17,35	14,5	28,00	37,00	35,00	50
M16x16	19,60	16,5	16,00	25,00	23,00	50
M16x24	19,60	16,5	24,00	33,00	31,00	50
M16x32	19,60	16,5	32,00	41,00	39,00	50
M16X40	19,60	16,5	40,00	49,00	47,00	50
M18x18	22,00	18,75	18,00	29,25	26,75	25
M18x27	22,00	18,75	27,00	38,25	35,75	25
M18x36	22,00	18,75	36,00	47,25	44,75	25
M20x20	24,40	20,75	20,00	31,25	28,75	25
M20x30	24,40	20,75	30,00	41,25	38,75	25
M20x40	24,40	20,75	40,00	51,25	48,75	25
M24x24	29,10	24,75	24,00	37,50	34,50	25
M24x36	29,10	24,75	36,00	49,50	46,50	25
M24x48	29,10	24,75	48,00	61,50	58,50	25

Draht-Gewindeeinsätze nach DIN 8140 eignen sich zur Gewindereparatur, Gewindeverstärkung und Gewindepanzerung. Die im Nennmaß angegebene Länge bezieht sich auf den Gewindeeinsatz im eingebauten Zustand (T).
 Toleranz: 6H Zugfestigkeit: >1400 N/mm² Temperaturbeständigkeit: 315 C° langfristig / 425 C° kurzzeitig
 Lieferbar in Edelstahl A2 (1.4301)
 Auch mit Klemmung oder als Feingewinde lieferbar.

Für den Einbau der Gewindeeinsätze wird Montagewerkzeuge benötigt.

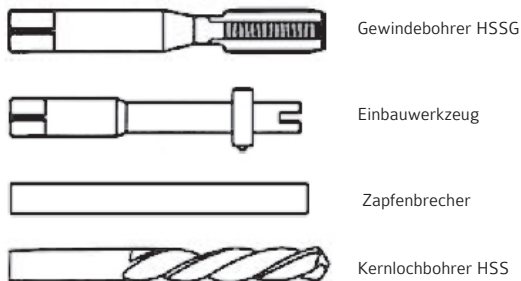

¹⁾ Außendurchmesser des Gewindeeinsatzes vor dem Einbau
²⁾ empf. Spiralbohrer
³⁾ Länge des Gewindeeinsatzes im eingebauten Zustand
⁴⁾ Mindestdiefe des Kernlochs, ohne Spitze
⁵⁾ Gewindetiefe mit Anschnitt

Maße in mm

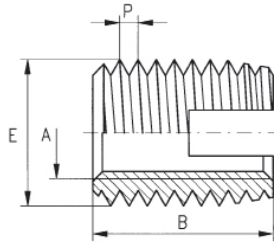

A	M2	M2,5	M3	M4	M5	M6	M6A
P ¹⁾	0,5	0,5	0,5	0,75	1	1,5	1
B	6	6	6	8	10	14	12
E	4,5	4,5	5	6,5	8	10	9
T ²⁾	8	8	8	10	13	17	15
VPE	250	250	200	200	200	200	200

A	M8	M10	M12	M14	M16	M20	M24	M30
P ¹⁾	1,5	1,5	1,5	1,5	1,5	1,5	1,5	1,5
B	15	18	22	24	22	27	30	40
E	12	14	16	18	20	26	30	36
T ²⁾	18	22	26	28	27	32	36	46
VPE	100	100	50	50	50	25	25	25

Der Gewindeinsatz mit Schneidschlitz ist ein selbstschneidendes Verbindungselement zur Herstellung hochbelastbarer, verschleißfester und vibrationssicherer Schraubverbindungen in Werkstoffen mit geringer Scherfestigkeit.

Er eignet sich zum Einbau in folgende Werkstoffe: Leichtmetall-Legierungen, Gusseisen, Messing, Bronze, NE-Metalle, Kunststoffe, Schichtstoffe und Harthölzer.

Lieferbar in Stahl, Messing sowie Edelstahl

¹⁾ Gewindesteigung

²⁾ Mindestlochtiefe (Sacklöcher)





Maße in mm

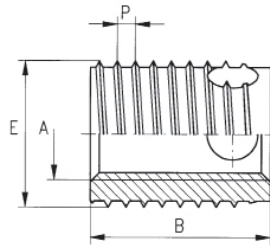

A	M3	M4	M5	M6	M8	M10	M12	M16
P ¹⁾	0,6	0,8	1	1,25	1,5	1,5	1,75	2
B	4	6	7	8	9	10	12	14
E	5	6,5	8	10	12	14	16	20
T ²⁾	6	8	9	10	11	13	15	17
VPE	250	250	250	250	250	250	100	100

Der Gewinde-Einsatz Ensat-SB Typ mit Schneidbohrungen ist ein selbstschneidendes Verbindungselement zur Herstellung hochbelastbarer, verschleißfester und vibrationsicherer Schraubverbindungen in Werkstoffen mit geringer Scherfestigkeit. Er eignet sich zum Einbau in folgende Werkstoffe: Aluminium, Aluminium-Legierungen, Magnesium-Legierungen, Duroplaste, Thermoplaste (ausgenommen gummiweiche Thermoplaste < 100 Shore A)

Lieferbar in Stahl, Messing sowie Edelstahl

¹⁾ Gewindesteigung

²⁾ Mindestlochtiefe (Sacklöcher)

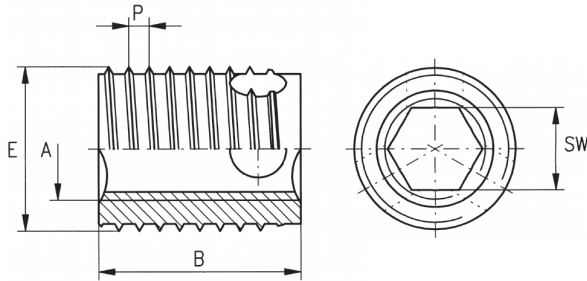

Maße in mm

A	M4	M5	M6	M8	M10
P ¹⁾	0,8	1	1,25	1,5	1,5
B	6	7	8	9	10
E	6,5	8	10	12	14
T ²⁾	8	9	10	11	13
SW	3,2	4,1	4,9	6,6	8,3
VPE	250	250	250	250	250

Der Gewinde-Einsatz mit Innensechskant ist ein selbstschneidendes Verbindungselement zur Herstellung hochbelastbarer, verschleißfester und vibrations sicherer Schraubverbindungen in Werkstoffen mit geringer Scherfestigkeit. Das Eindrehen des Ensat erfolgt über den Innensechskant, wodurch kürzere Montagezeiten erzielt werden. Weitere Vorteile: einfachere Eindrehwerkzeuge sowie Montagemaschinen, bei denen nur ein „Rechtslauf“ erforderlich ist. Bei der Verwendung in Kunststoffen lässt sich dieser Ensat vor dem Recycling der Kunststoffe problemlos ausdrehen. Ergebnis: weniger Kosten.

Er eignet sich zum Einbau in folgende Werkstoffe: Aluminium, Aluminium-Legierungen, Magnesium-Legierungen, Duroplaste, Thermoplaste (ausgenommen gummiweiche Thermoplaste < 100 Shore A)

Lieferbar in Stahl, Messing sowie Edelstahl

¹⁾ Gewindesteigung

²⁾ Mindestlochtiefe (Sackloch)





Maße in mm

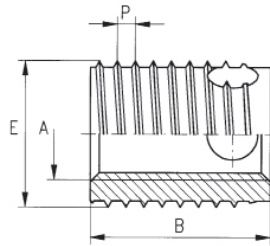

A	M3	M4	M5	M6	M8	M10	M12	M16
P ¹⁾	0,6	0,8	1	1,25	1,5	1,5	1,75	2
B	6	8	10	12	14	18	22	24
E	5	6,5	8	10	12	14	16	20
T ²⁾	8	10	13	15	17	22	26	28
VPE	250	250	250	250	250	250	100	100

Der Gewinde-Einsatz mit Schneidbohrungen ist ein selbstschneidendes Verbindungselement zur Herstellung hochbelastbarer, verschleißfester und vibrations sicherer Schraubverbindungen in Werkstoffen mit geringer Scherfestigkeit. Er eignet sich zum Einbau in folgende Werkstoffe: Aluminium, Aluminium-Legierungen, Magnesium-Legierungen, Duroplaste, Thermoplaste (ausgenommen gummiweiche Thermoplaste < 100 Shore A)

Lieferbar in Stahl, Messing sowie Edelstahl

¹⁾ Gewindesteigung

²⁾ Mindestlochtiefe (Sacklöcher)

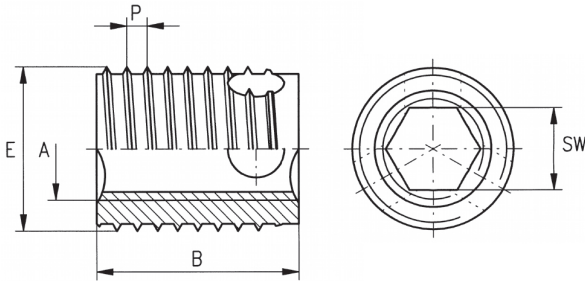

Maße in mm

A	M4	M5	M6	M8	M10
P ¹⁾	0,8	1	1,25	1,5	1,5
B	8	10	12	14	18
E	6,5	8	10	12	14
T ²⁾	10	13	15	17	22
SW	3,2	4,1	4,9	6,6	8,3
VPE	250	250	250	250	250

Der Gewinde-Einsatz mit Innensechskant ist ein selbstschneidendes Verbindungselement zur Herstellung hochbelastbarer, verschleißfester und vibrationsicherer Schraubverbindungen in Werkstoffen mit geringer Scherfestigkeit. Das Eindrehen des Einsatz erfolgt über den Innensechskant, wodurch kürzere Montagezeiten erzielt werden. Weitere Vorteile: einfachere Eindrehwerkzeuge sowie Montagemaschinen, bei denen nur ein „Rechtslauf“ erforderlich ist. Bei der Verwendung in Kunststoffen lässt sich dieser Einsatz vor dem Recycling der Kunststoffe problemlos ausdrehen. Ergebnis: weniger Kosten.

Er eignet sich zum Einbau in folgende Werkstoffe: Aluminium, Aluminium-Legierungen, Magnesium-Legierungen, Duroplaste, Thermoplaste (ausgenommen gummiweiche Thermoplaste < 100 Shore A)

Lieferbar in Stahl, Messing sowie Edelstahl

¹⁾ Gewindesteigung

²⁾ Mindestlochtiefe (Sackloch)



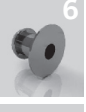





Maße in mm

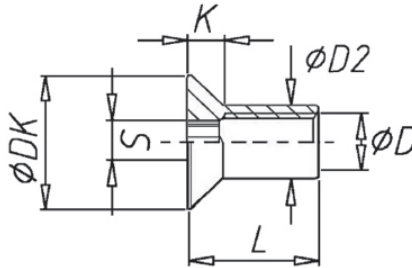

Nennmaß	D	D2	DK	K	L	S	VPE
M4X12	4	5	8	2	12	2,5	100
M5X15	5	6,5	10	2	15	3	100
M6X16	6	8	12	3	16	4	100
M8X16	8	11	16	3	16	5	100
M10X20	10	14	20	4	20	6	100
M12X20	12	16	24	4	20	8	100

Bei nicht genormten Teilen können die angegebenen Maße herstellungsbedingt abweichen.
 Lieferbar in Edelstahl A2

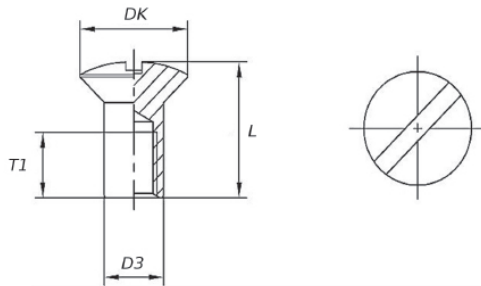

Maße in mm

D	M4	M5	M6	M8
D3	5	6	7,5	10
DK	7	9	10	15

Bei nicht genormten Teilen können die angegebenen Maße herstellungsbedingt abweichen.

VPE

L \ D	M4	M5	M6	M8
7	100	–	–	–
10	100	100	100	–
12	100	–	–	–
14	100	–	–	–
15	–	100	100	–
20	100	100	100	100
25	–	–	–	100

Die handelsüblichen Größen sind durch Angabe der VPE gekennzeichnet.
Lieferbar in Edelstahl A2 sowie Messing





Maße in mm

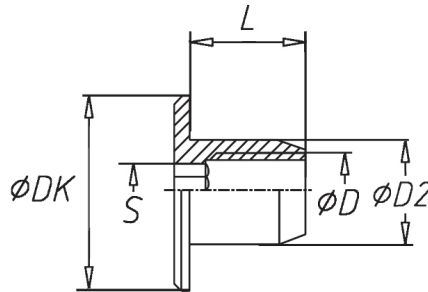

Nennmaß	D	D2	DK	L	S	VPE1
RF M6-13X8X9	M6	8	13	9	5	100
RF M6-15X9X10	M6	9	15	10	5	100
RF M6-20X9X10	M6	9	20	10	5	100
RF M6-20X9X15	M6	9	20	15	5	100
RF M8-20X10X10	M8	10	20	10	5	100
RF M8-25X10X15	M8	10	25	15	5	100
RF M8-25X10X20	M8	10	25	20	5	100
RF M10-30X14X18	M10	14	30	18	5	100

RAMPA-Rundmuttern Typ RF mit Innensechskant, durchgehend zum Innengewinde, dekorativer Flachkopf bei sichtbaren Verbindungen.
 Lieferbar in Stahl, Edelstahl sowie Messing

Maße in mm

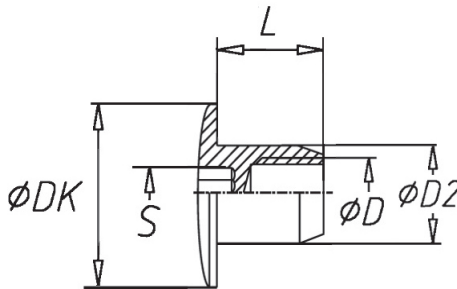

Nennmaß	D	D2	DK	L	S
RTL M5-12X6,5X13	M5	6,5	12	13	4
RTL M6-13X8X10	M6	8	13	10	5
RTL M6-15X8X12	M6	8	15	12	4
RTL M6-15X9X12	M6	9	15	12	4
RTL M6-15X8X15	M6	8	15	15	5
RTL M6-15X9X15	M6	9	15	15	4
RTL M6-15X9X18	M6	9	15	18	4
RTL M6-19X9X16	M6	9	19	16	5
RTL M6-19X9X20	M6	9	19	20	5
RTL M8-20X10X14	M8	10	20	14	5
RTL M8-20X10X16	M8	10	20	16	5
RTL M8-20X10X20	M8	10	20	20	6
RTL M10-20X13X13	M10	13	20	13	5

RAMPA-Rundmuttern Typ RTL mit Sacklochgewinde und Flachrundkopf, dekorativ bei sichtbaren Verbindungen. Lieferbar in Stahl, Edelstahl sowie Messing





Maße in mm

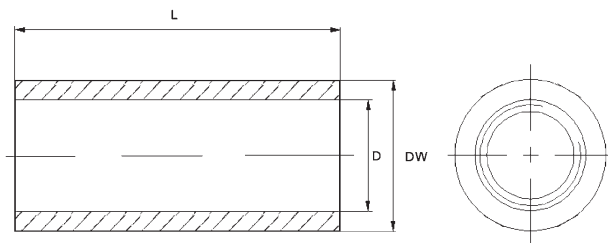

D	M4	M5	M6	M8	M10	M12	M16	M20
DW	7	8	10	11	13	15	22	28

Bei nicht genormten Teilen können die angegebenen Maße herstellungsbedingt abweichen.

VPE

L \ D	M4	M5	M6	M8	M10	M12	M16	M20
15	100	100	100	100	–	–	–	–
20	100	100	100	100	100	100	–	–
25	–	100	100	100	100	100	–	–
30	–	100	100	100	100	100	–	–
40	–	–	100	100	100	100	100	25
50	–	–	100	100	100	100	50	25
60	–	–	–	–	100	100	25	25
80	–	–	–	–	–	–	25	25

Die handelsüblichen Größen sind durch Angabe der VPE gekennzeichnet.
Lieferbar in Stahl sowie Edelstahl A2

Maße in mm

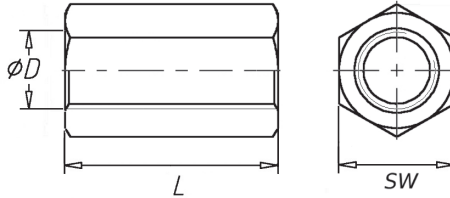

Nennmaß	D	L	SW	VPE
3X10 SW5,5	3	10	5,5	100
3X12 SW6	3	12	6	100
3X14 SW5,5	3	14	5,5	100
3X15 SW5,5	3	15	5,5	100
3X20 SW5,5	3	20	5,5	100
3X20 SW6	3	20	6	100
3X30 SW5,5	3	30	5,5	100
3X35 SW5,5	3	35	5,5	100
4X10 SW8	4	10	8	100
4X12 SW7	4	12	7	100
4X16 SW7	4	16	7	100
4X20 SW7	4	20	7	100
4X25 SW7	4	25	7	100
4X30 SW8	4	30	8	100
4X40 SW7	4	40	7	100
4X40 SW8	4	40	8	100
4X50 SW7	4	50	7	100
4X60 SW7	4	60	7	100
4X75 SW7	4	75	7	100
5X15 SW8	5	15	8	100
5X20 SW8	5	20	8	100
5X25 SW8	5	25	8	100

Nennmaß	D	L	SW	VPE
5X30 SW8	5	30	8	100
6X15 SW10	6	15	10	100
6X20 SW10	6	20	10	100
6X25 SW10	6	25	10	100
6X30 SW10	6	30	10	100
6X35 SW10	6	35	10	100
6X40 SW10	6	40	10	100
6X50 SW10	6	50	10	100
6X60 SW10	6	60	10	100
8X20 SW11	8	20	11	100
8X20 SW13	8	20	13	100
8X30 SW11	8	30	11	100
8X30 SW13	8	30	13	100
8X35 SW13	8	35	13	100
8X40 SW11	8	40	11	100
8X40 SW13	8	40	13	100
8X50 SW11	8	50	11	50
8X50 SW13	8	50	13	50
8X60 SW13	8	60	13	50
10X20 SW13	10	20	13	100
10X20 SW17	10	20	17	100
10X30 SW13	10	30	13	100





1



2



3



4



5



6



7



8



9

Nennmaß	D	L	SW	VPE	Nennmaß	D	L	SW	VPE
10X30 SW17	10	30	17	50	12X60 SW19	12	60	19	25
10X40 SW13	10	40	13	50	16X30 SW24	16	30	24	25
10X40 SW17	10	40	17	50	16X40 SW24	16	40	24	50
10X50 SW17	10	50	17	50	16X50 SW24	16	50	24	50
10X60 SW17	10	60	17	50	16X60 SW24	16	60	24	25
12X30 SW17	12	30	17	50	20X50 SW30	20	50	30	25
12X30 SW19	12	30	19	50	20X60 SW30	20	60	30	25
12X40 SW17	12	40	17	50	24X50 SW36	24	50	36	25
12X40 SW19	12	40	19	50	24X60 SW36	24	60	36	10
12X50 SW17	12	50	17	50					

Lieferbar in Stahl sowie Edelstahl A2

Maße in mm

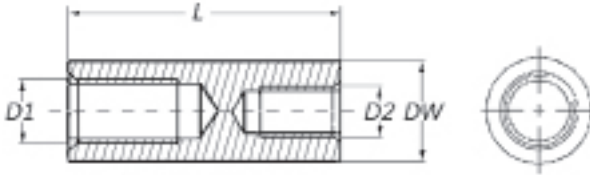

Nennmaß	D1	D2	DW	L	VPE 1
M6-M8	M6	M8	13	40	100
M6-M10	M6	M10	16	40	100
M8-M10	M8	M10	16	40	100
M8-M12	M8	M12	16	40	100
M10-M12	M10	M12	16	40	100
M10-M16	M10	M16	22	40	100
M12-M16	M12	M16	22	40	100

Bei nicht genormten Teilen können die angegebenen Maße herstellungsbedingt abweichen.
Lieferbar in: Stahl sowie Edelstahl A2





Maße in mm

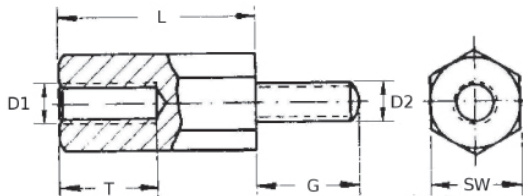

Nennmaß	D1	D2	T	G	SW	L	VPE
M3X5 SW5,5	M3	M3	2.5	6	5.5	5	200
M3X6 SW5,5	M3	M3	3	6	5.5	6	200
M3X8 SW5,5	M3	M3	5	6	5.5	8	200
M3X10 SW5,5	M3	M3	6	6	5.5	10	200
M3X12 SW5,5	M3	M3	7	6	5.5	12	200
M3X15 SW5,5	M3	M3	7	6	5.5	15	200
M3X18 SW5,5	M3	M3	7	6	5.5	18	200
M3X20 SW5,5	M3	M3	7	6	5.5	20	200
M3X25 SW5,5	M3	M3	7	6	5.5	25	100
M3X30 SW5,5	M3	M3	7	6	5.5	30	100
M3X35 SW5,5	M3	M3	7	6	5.5	35	100
M3X40 SW5,5	M3	M3	7	6	5.5	40	100
M4X8 SW7	M4	M4	5	8	7	8	100
M4X8 SW8	M4	M4	6	8	8	8	100
M4X10 SW7	M4	M4	6	8	7	10	100
M4X10 SW8	M4	M4	6	8	8	10	100
M4X12 SW7	M4	M4	8	8	7	12	100
M4X12 SW8	M4	M4	8	8	8	12	100
M4X15 SW7	M4	M4	9	8	7	15	100
M4X15 SW8	M4	M4	9	8	8	15	100
M4X20 SW7	M4	M4	9	8	7	20	100
M4X20 SW8	M4	M4	9	8	8	20	100

Nennmaß	D1	D2	T	G	SW	L	VPE
M4X25 SW7	M4	M4	9	8	7	25	100
M4X25 SW8	M4	M4	9	8	8	25	100
M4X30 SW7	M4	M4	9	8	7	30	100
M4X30 SW8	M4	M4	9	8	8	30	100
M4X35 SW7	M4	M4	9	8	7	35	100
M4X35 SW8	M4	M4	9	8	8	35	100
M4X40 SW7	M4	M4	9	8	7	40	100
M4X40 SW8	M4	M4	9	8	8	40	100
M4X45 SW7	M4	M4	9	8	7	45	100
M4X45 SW8	M4	M4	9	8	8	45	100
M4X50 SW7	M4	M4	9	8	7	50	100
M4X50 SW8	M4	M4	9	8	8	50	100
M4X60 SW7	M4	M4	9	8	7	60	100
M4X60 SW8	M4	M4	9	8	8	60	100
M5X10 SW8	M5	M5	6	10	8	10	200
M5X15 SW10	M5	M5	11	10	10	15	200
M5X20 SW8	M5	M5	11	10	8	20	200
M5X20 SW10	M5	M5	11	10	10	20	200
M5X25 SW8	M5	M5	11	10	8	25	100
M5X25 SW10	M5	M5	11	10	10	25	100
M5X30 SW8	M5	M5	11	10	8	30	100
M5X30 SW10	M5	M5	11	10	10	30	100
M5X35 SW8	M5	M5	11	10	8	35	100
M5X35 SW10	M5	M5	11	10	10	35	100
M5X40 SW8	M5	M5	11	10	8	40	100
M5X40 SW10	M5	M5	11	10	10	40	100
M5X45 SW8	M5	M5	11	10	8	45	100
M5X45 SW10	M5	M5	11	10	10	45	100
M5X50 SW8	M5	M5	11	10	8	50	100
M5X50 SW10	M5	M5	11	10	10	50	100
M5X60 SW8	M5	M5	11	10	8	60	100





Nennmaß	D1	D2	T	G	SW	L	VPE
M5X60 SW10	M5	M5	11	10	10	60	100
M5X65 SW10	M5	M5	11	10	10	65	100
M5X70 SW8	M5	M5	11	10	8	70	100
M5X70 SW10	M5	M5	11	10	10	70	100
M5X80 SW8	M5	M5	11	10	8	80	100
M5X80 SW10	M5	M5	11	10	10	80	100
M6X10 SW10	M6	M6	6	12	10	10	200
M6X12 SW10	M6	M6	8	12	10	12	200
M6X15 SW10	M6	M6	12	12	10	15	200
M6X20 SW10	M6	M6	12	12	10	20	200
M6X25 SW10	M6	M6	12	12	10	25	100
M6X30 SW10	M6	M6	14	12	10	30	100
M6X35 SW10	M6	M6	14	12	10	35	100
M6X40 SW10	M6	M6	14	12	10	40	100
M6X45 SW10	M6	M6	14	12	10	45	100
M6X50 SW10	M6	M6	14	12	10	50	100
M6X55 SW10	M6	M6	14	12	10	55	100
M6X60 SW10	M6	M6	14	12	10	60	100
M6X65 SW10	M6	M6	14	12	10	65	100
M6X70 SW10	M6	M6	14	12	10	70	100
M6X80 SW10	M6	M6	14	12	10	80	100
M6X90 SW10	M6	M6	14	12	10	90	100
M6X95 SW10	M6	M6	14	12	10	95	100
M6X100 SW10	M6	M6	14	12	10	100	100
M8X20 SW13	M8	M8	15	14	13	20	100
M8X25 SW13	M8	M8	16	14	13	25	100
M8X30 SW13	M8	M8	16	14	13	30	100
M8X35 SW13	M8	M8	16	14	13	35	100
M8X40 SW13	M8	M8	16	14	13	40	100
M8X50 SW13	M8	M8	16	14	13	50	100
M8X60 SW13	M8	M8	16	14	13	60	100

Nennmaß	D1	D2	T	G	SW	L	VPE
M8X70 SW13	M8	M8	16	14	13	70	100
M8X80 SW13	M8	M8	16	14	13	80	100
M8X90 SW13	M8	M8	16	14	13	90	100
M8X100 SW13	M8	M8	16	14	13	100	100

Bei nicht genormten Teilen können die angegebenen Maße herstellungsbedingt abweichen.
Lieferbar in Stahl sowie Edelstahl A2



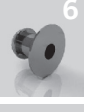

	Seite
Mechanische Eigenschaften	514
Geometrie	527
Kennzeichnung	536
Gewinde	548
Korrosion	556
Korrosionsschutz	558
Montage	568
Sicherung von Schraubenverbindungen	580
Prüfbescheinigungen	591
Vergleichstabellen DIN/EN/ISO	593

1



2



3



4



5



6



7



8



9





1

Bezeichnungssystem der Festigkeitsklassen von Schrauben:

Eine Zahlenkombination kennzeichnet die wichtigsten mechanischen Eigenschaften einer Schraube. Sie besteht aus zwei Zahlen, so zum Beispiel:



2

Die erste Zahl gibt 1/100 der Mindestzugfestigkeit- in N/mm^2 an.



3

Zugfestigkeit $8 \times 100 = 800 N/mm^2$



4



5



6



7

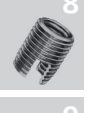

8



9

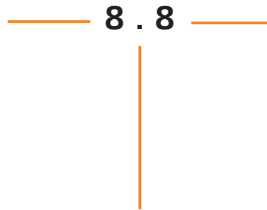

Die zweite Zahl gibt das 10fache des Verhältnisses der Dehnstreckgrenze (ReL bzw. $R_{p0,2}$) zur Nennzugfestigkeit R_m (Streckgrenzenverhältnis) an.

$$\frac{\text{Mindeststreckgrenze ReL}}{\text{Mindestfestigkeit Rm}} \times 10$$

Die Multiplikation beider Zahlen ergibt 1/10 der Mindeststreckgrenze in N/mm^2
Mindeststreckgrenze $8 \times 8 \times 10 = 640 N/mm^2$

Mechanische Eigenschaften von Schrauben aus Stahl

Als die wichtigsten mechanischen Eigenschaften einer Schraubenverbindung gelten die folgenden:

- Zugfestigkeit R_m
- Streckgrenze ReL
- 0,2 Dehngrenze $R_{p0,2}$
- Bruchdehnung A_5

Zugfestigkeit R_m in N/mm^2

Die Zugfestigkeit ist die Spannung, bei der die unversehrte Schraube die höchste Kraft ertragen muss.

Streckgrenze ReL in N/mm^2

Die Streckgrenze ist die Spannung, bei der an relativ weichen Werkstoffen mit zunehmender Dehnung der Probe die Zugkraft erstmalig gleich bleibt oder kurzzeitig abfällt.

0,2 Dehngrenze $R_{p0,2}$ in N/mm^2

Die Streckgrenze ist bei härteren Werkstoffen nicht mehr scharf ausgeprägt. An ihre Stelle tritt die Spannung, bei der die bleibende Dehnung 0,2% beträgt.

Dehnung A_5 in % (Bruchdehnung)

Die Dehnung gibt an, in welchem Ausmaß (um wie viel %) die ursprüngliche Schaftlänge bis zum Bruch der Schraube zugenommen hat.

A_5 = bezieht sich auf den Probestab, der eine Länge von $5 \times d$ hat.

Eigenschaften		3.6	4.6	4.8	5.6	5.8	8.8		10.9	12.9
							≤ M16	> M16		
Nennzugfestigkeit	N/mm ²	300	400	400	500	500	800	800	1000	1200
Mindestzugfestigkeit	N/mm ²	330	400	420	500	520	800	830	1040	1220
Vickershärte HV	min	95	120	130	155	160	250	255	320	385
	max			250			320	335	380	435
Untere Streckgrenze in N/mm ²	Nennwert	180	240	320	300	400				
	min	190	240	340	300	420				
0,2%-Dehngrenze in N/mm ²	Nennwert						640	640	900	1080
	min						640	660	940	1100
Bruchdehnung in %	min	25	22	14	20	10	12	12	9	8

Die mechanischen Eigenschaften von Schrauben gelten für die Prüfung bei Raumtemperatur.



Mechanische Eigenschaften

Übersicht allgemein üblicher Schraubenwerkstoffe



	Festigkeits- klasse	Kaltverfor- mung	Warmverfor- mung	Zerspanen	Schrauben- durchmesser
1					
2	3.6	1.0203	1.0110	1.0711	bis M 39
	4.6	1.0204 1.0217 1.0224	1.0419		
3	4.8	1.0203 1.0204		1.0711	üblich bis M 16
	5.6	1.1152	1.0533		bis M 39
4	5.8	1.1152 1.1172		1.0715 1.0721	bis M 39
	<u>8.8</u>	1.5508 1.5510	1.5508 1.5510	nicht üblich	bis M 12
5	8.8	1.5511 1.1172 1.1192	1.0503 1.7002	wenig bzw. nicht üblich	bis M 22
		1.7033 1.7034	1.7006		M 24 - M 39
6	10.9	1.5511 1.1172 1.7033	1.5511 1.1172	wenig bzw. nicht üblich	bis M 6
					M 8 - M 18
		1.7035 1.7220 1.7225	1.7035 1.7035 1.7220 1.7225		bis M 39
8	12.9	1.7220 1.7034 1.7035	1.7220 1.7034 1.7035	wenig bzw. nicht üblich	bis M18
		1.7225	1.7225		bis M 24
		1.6582	1.6582		bis M 39
9					

Bezeichnungssystem der Festigkeitsklassen für Muttern mit Nennhöhe $\geq 0,8 D$

Bei der Festigkeitsklasse dieser Muttern wird nur eine Kennzahl angegeben. Diese gibt ca. 1/100 der Prüfspannung in N/mm^2 an und entspricht der höchsten Schraubenklasse, mit der die Mutter gepaart werden darf. Beispiel:

8

Diese Zahl gibt 1/100 der Prüfspannung in N/mm^2 an.
 Prüfspannung $800 N/mm^2$

Eine Schraube der Festigkeitsklasse 8.8 wird mit einer Mutter der Festigkeitsklasse 8 (oder höher) gepaart. So kann die Schraube in dieser Verbindung bis zur Streckgrenze belastet werden.

Bezeichnungssystem der Festigkeitsklassen für Muttern mit Nennhöhen $\geq 0,5 D$, jedoch $< 0,8 D$

Diese Muttern werden mit einer zweistelligen Zahl gekennzeichnet. Die erste Ziffer weist darauf hin, dass die Belastbarkeit einer mit einer solchen Mutter gebildeten Schraubenverbindung geringer ist als die einer Schraubenverbindung mit einer Mutter mit Nennhöhe $\geq 0,8 D$.

Bei Muttern für Schraubenverbindungen mit eingeschränkter Belastbarkeit gilt das folgende Kennzeichnungssystem, z. B.:

Hinweis auf Einschränkung ——— **05** ——— 1/100 der Prüfspannung

Für diese flachen Muttern sind Prüfkräfte und Abstreiffestigkeiten in Abhängigkeit zur eingesetzten Schraube festgelegt. Muttern nach DIN 934 sind nicht mit Sicherheit bis zur Streckgrenze der entsprechenden Schraube belastbar. Zur Unterscheidung gegenüber voll belastbaren Muttern wird die Kennzeichnung der Festigkeitsklasse durch zwei senkrechte Balken vor und hinter der Kennzahl ergänzt, z.B. I8I.





1

Mechanische Eigenschaften von Muttern aus Stahl

Als die wichtigsten Eigenschaften einer Mutter gelten die

- Prüfspannung
- Härte



2



3

Prüfspannung S_p in N/mm^2

Die Prüfspannung ist die Spannung, die die Mutter im Prüfkraftversuch ertragen muss. Diese muss bei der Paarung mit der Mindestzugfestigkeit der gewählten Schraube übereinstimmen.

Härte (Vickershärte HV)

Die Muttern müssen gehärtet werden, damit annähernd die gleichen Festigkeitswerte wie die der Schrauben erzielt werden können.



4

Die Prüfkraft, ist die für den Prüfkraftversuch errechnete und für alle gängigen Gewinde vorgegebene Kraft (ISO 898 Teil 2).



5



6

Festigkeitsklassen und mechanische Eigenschaften von Muttern (nach DIN EN 20898-2)



7



8



9

Gewinde-nenn- \emptyset in mm		Festigkeitsklasse								
		04			05			5		
		Prüfspannung S_p	Vickershärte HV		Prüfspannung S_p	Vickershärte HV		Prüfspannung S_p	Vickershärte HV	
über	bis	N/mm^2	min	max	N/mm^2	min	max	N/mm^2	min	max
-	4	380	188	302	500	272	353	520	130	302
4	7							580		
7	10							590		
10	16							610		
16	39							630		

Gewinde-nenn- \emptyset in mm		8		10			12				
		Prüfspannung S_p		Vickershärte HV		Prüfspannung S_p		Vickershärte HV		Prüfspannung S_p	
über	bis	N/ mm ²	min	max	N/ mm ²	min	max	N/ mm ²	min	max	
-	4	800	180	302	1040	272	353	1140	272	353	
4	7	855	1040		1140						
7	10	870	1040		1140						
10	16	880	1050		1170						
16	39	920	233	353	1060						

Die Mindesthärten sind nur verbindlich für Muttern, bei denen ein Prüfkraftversuch nicht durchgeführt werden kann und bei vergüteten Muttern. Für alle anderen Muttern gelten die Mindesthärten nur als Richtlinie.

Abstreiffestigkeit für Muttern mit Nennhöhe von 0,5 d nach DIN ISO 898, Teil 2

Die Richtwerte beziehen sich auf die angegebenen Schraubenklassen. Ein Abstreifen des Bolzen gewindes kann erwartet werden, wenn die Muttern mit niedrigeren Schraubenklassen gepaart werden. Bei Paarung mit höheren Schraubenklassen sollte in der Regel ein Ausstreifen des Gewindes der Mutter erfolgen.

Festigkeitsklasse der Mutter	Prüfspannung der Mutter in N/mm ²	Mindestspannung in der Schraube vor dem Abstreifen in N/mm ² bei Paarung mit Schrauben der Festigkeitsklasse		
		8.8	10.9	12.9
04	380	300	330	350
05	500	370	410	480



Mechanische Eigenschaften

Übersicht allgemein üblicher Mutternwerkstoffe



Festigkeitsklasse	Ausgangswerkstoffe für Herstellung durch			Gewinde- Ø	Endzustand der Muttern	
	Kaltformen	Warmformen	Zerspanen		verformt	zerspan
4, 5, 6	UQSt 36-2 1.0204	UST 36-2 1.0203	St 34-2 1.0151 St 37-2 1.0161 35 S 20 k 1.0726 9 S 20 k 1.0711		keine Nachbehandlung	kaltgezogen
8	UQSt 36-2 Cq22 Cq35	C 22 1.0402 C 35 1.0501	35 S 20 k 1.0726 45 S 20 k 1.0727	≤ M 16		
10 und 12	Cp35 Cp45	C 35 1.0501 c 45 1.0503	c 35 1.0501 c 45 1.0503	> M 16	vergütet	vergütet

Bezeichnungssystem

Eine Buchstaben-Zahlen-Kombination kennzeichnet die wichtigsten Eigenschaften, z. B.:

A2-70

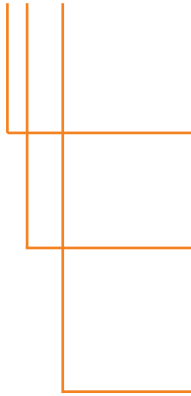

Kurzzeichen der Stahlart

A = Austenitischer CrNi-Stahl

Kurzzeichen der Stahlgruppe

1 = Automatenstahl mit Schwefelzusatz

2 = Chrom-Nickel-Legierung

4 = Chrom-Nickel-Molybdän-Legierung

Kurzzeichen der Festigkeitsklassen

50 = 1/10 der Zugfestigkeit (min. 500 N/mm)

70¹ = 1/10 der Zugfestigkeit (min. 700 N/mm)

80 = 1/10 der Zugfestigkeit (min. 800 N/mm)

¹ handelsübliche Festigkeitsklasse für $D \leq 24$ mm bei gestempelten Normteilen

Mechanische Eigenschaften von Schrauben und Muttern aus nicht rostendem austenitischem CrNi-Stahl (nach DIN EN ISO 3506-1/-2)

Die wichtigste Eigenschaft bei diesen Verbindungselementen liegt in der Korrosionsbeständigkeit. Weiter gilt zu beachten, dass keine Wärmebehandlung stattfindet, d. h. dass die Festigkeit dieser Elemente lediglich durch Kaltverfestigung bei der Herstellung erzielt wird.

1



2



3



4



5



6



7



8



9



Mechanische Eigenschaften

Mechanische Eigenschaften für Verbindungselemente
der austenitischen Stahlgruppe



Mechanische Eigenschaften für Schrauben der austenitischen Stahlgruppe

Stahlgruppe	Stahl-sorte	Festig-keitsklasse	Durchmes-serbereich	Zugfestig-keit in N/mm ² (min.)	0,2%-Dehngren-ze in N/mm ² (min.)	Bruchdeh-nung in mm (min.)
Austenitisch	A1 A2	50	≤ M 39	500	210	0,6 d
	A3 A4	70	≤ M 24	700	450	0,4 d
	A5	80	≤ M 24	800	600	0,3 d



Mechanische Eigenschaften für Muttern der austenitischen Stahlgruppe

Stahlgruppe	Stahl-sorte	Festigkeitsklasse		Durchmes-serbereich	Prüfspannung SP N/mm ² min	
		Muttern Typ m ≥ 0,8d	Niedrige Muttern 0,5d ≤ m < 0,8d		Muttern Typ m ≥ 0,8d	Niedrige Muttern 0,5d ≤ m < 0,8d
Austenitisch	A1 A2	50	025	≤ M 39	500	250
	A3 A4	70	035	≤ M 24	700	350
	A5	80	040	≤ M 24	800	400

Mechanische Eigenschaften

Chemischen Zusammensetzung von
austenitischen Stählen (Auswahl)

Kurz- Bez.	DIN-Werk- stoffnum- mer	C	Si	Mn	P	S	Cr	Mo	Ni	An- dere
		%	%	%	%	%	%	%	%	
A1	1.4305	0,10	1,0	2,0	0,045	0,15- 0,35	17,0- 19,0	-	8,0- 10,0	Cu / N
A2	1.4301	0,07	1,0	2,0	0,045	0,015	17,0- 19,5	-	8,0- 10,5	N
A2	1.4303	0,06	1,0	2,0	0,045	0,015	17,0- 19,0	-	11,0- 13,0	N
A2	1.4541	0,08	1,0	2,0	0,045	0,010	17,0- 19,0	-	9,0- 12,0	Ti
A4	1.4401	0,07	1,0	2,0	0,045	0,015	16,5- 18,5	2,0- 2,5	10,5- 13,0	N
A4	1.4436	0,05	1,0	2,0	0,045	0,015	16,5- 18,5	2,5- 3,0	10,5- 13,0	N
A4	1.4571	0,08	1,0	2,0	0,045	0,015	16,5- 18,5	2,0- 2,5	10,5- 13,0	Ti

Wichtigste Merkmale:

- A1 Vorwiegend für Drehteile, nicht schweißbar
- A2 Beschränkt säurebeständig, gut schweißbar
- A4 Hochsäurebeständig, gut schweißbar

Nichtrostenden Stähle sind kaltzäh und gut geeignet für den Einsatz bei tiefen Temperaturen (A2 von -200 °C bis +400 °C, A4 von -60 °C bis +400 °C nach DIN 267-13)



Mechanische Eigenschaften

Nichteisenmetalle nach ISO 8839



Kennzeichen	Kurzzeichen	Wst.-Nr.	Gewinde-Ø d	Zugfestigkeit in N/mm ² (min.)	0,2%-Dehnung in N/mm ² (min.)	Bruchdehnung in % (min.)
CU1	CuETP	2.0060	d ≤ M 39	240	160	14
CU2	CuZn37 (Ms63)	2.0321	d ≤ M 6	440	340	11
			M 6 < d ≤ M 39	370	250	19
CU3	CuZn39Pb3 (Ms58)	2.0401	d ≤ M 6	440	340	11
			M 6 < d ≤ M 39	370	250	19
CU4	CuSn6	2.1020	d ≤ M 12	470	340	22
			M12 < d ≤ M 39	440	200	33
CU5	CuNi1Si	2.0853	d ≤ M 39	590	540	12
CU6	CuZn40Mn1Pb	2.0580	M 6 < d ≤ M 39	440	180	18
CU7	CuAl10Ni5Fe4	2.0966	M 12 < d ≤ M 39	640	270	15
AL1	AlMg3	3.3535	d ≤ M 10	270	180	3
			M10 < d ≤ M 20	250	230	4
AL2	AlMg5	3.3555	d ≤ M 14	310	200	6
			M14 < d ≤ M 36	280	205	6
AL3	AlSi1MgMn	3.2315	d ≤ M 6	320	250	7
			M 6 < d ≤ M39	310	260	10
AL4	AlCuMgSi	3.1325	d ≤ M10	420	290	6
			M10 < d ≤ M39	380	260	10
AL5	AlZnMgCu 0,5	3.4345	d ≤ M39	460	380	7
AL6	AlZn5,5MgCu	3.4365	d ≤ M39	510	440	7

Kurzzeichen	Rohstoffgruppe (Handelsname)	Rohdichte	Streckspannung	Reißdehnung	Elastizitätsmodul	Dauergebrauchstemp.
		g/cm ³	ca. N/mm ²	ca. %	ca. N/mm ²	bis ca. °C
PA 6	Polyamid 6 (Ultramid)	1,14	80 ¹⁾ - 30 ²⁾	130 ¹⁾ - 220 ²⁾	2700 ¹⁾ - 1800 ²⁾	+100
PA 6.6	Polyamid 66 (Ultramid A)	1,14	85 ¹⁾ - 50 ²⁾	40 ¹⁾ - 170 ²⁾	3000 ¹⁾ - 1900 ²⁾	+100
POM	Polyacetal (Delrin 150)	1,42	69	30	3000	+100
PP	Polypropylen (Hostalen PPH)	0,91	30 ¹⁾ - 35 ²⁾	15	1000 - 1300	+80
PA 12	Polyamid 12	1,01	55 ¹⁾ - 48 ²⁾	150 ¹⁾ - 350 ²⁾	1800 ¹⁾ - 1300 ²⁾	+120 ¹⁾
PC	Polycarbonat	1,2	60	80 ¹⁾ - 100 ²⁾	2100	+130
PA 6.6 (gfv)	mit 35% Glasfaser	1,39	190 ¹⁾ - 140 ²⁾	5	9500 ¹⁾ - 8500 ²⁾	+140

¹⁾ trocken

²⁾ luftfeucht





1

Eigenschaften von Schrauben und Muttern aus Polyamid PA 6.6



2

Thermisch

Schmelzpunkt	250 - 260 °C
Wärmeleitfähigkeit	0,29 W/mK
Formbeständigkeit	100 °C
Gebrauchstemperatur	normal 80 °C dauerhaft 100 °C
maximal, kurzfristig	150 °C
Kälteformbeständigkeit	30 °C



3



4

Brennverhalten

Brennbarkeit (UL 94)	V-2
Brenngeschwindigkeit:	< 100 mm/min
Glühdrahtprüfung	960 °C



5

Elektrisch

Kriechwegbildung (CTI nach IEC 112)	600 Prüflösung A
-------------------------------------	------------------



6

Chemische Beständigkeit bei 20 °C

Mineralöle	beständig
Benzin	beständig
Trichloräthylen	bedingt beständig
Tetrachlorkohlenwasserstoff	beständig
verdünnte Säuren	bedingt beständig
verdünnte Laugen	beständig



7



8



9

Schlüsselweiten Innensechskant

SW	DIN 912	DIN 7984	DIN 7991	DIN 913 - 916	DIN 6912	ISO 7379	ISO 7380
1,5	M2	-	-	M3	-	-	-
2	M2,5	M3	M3	M4	-	-	M3
2,5	M3	M4	M4	M5	-	-	M4
3	M4	M5	M5	M6	M4	M5	M5
4	M5	M6	M6	M8	M5	M6	M6
5	M6	M8	M8	M10	M6	M8	M8
6	M8	-	M10	M12 M14	M8	M10	M10
7	-	M10	-	-	-	-	-
8	M10	M12	M12	M16	M10	M12	M12
10	M12	M14	M14 M16	M18 M20	M12	M16	-
12	M14	M16 M18	M18 M20	M22 M24	M14	M20	-
14	M16 M18	M20 M22	M22 M24	-	M16 M18	-	-
17	M20 M22	M24	-	-	M20 M22	-	-
19	M24 M27	-	-	-	M24	-	-
22	M30	-	-	-	-	-	-

Schlüsselweiten Außensechskant

Größe	DIN 931 / 934 ~7990	DIN EN 14399
M2	4	-
M2,5	5	-
M3	5,5	-
M3,5	6	-
M4	7	-
M5	8	-
M6	10	-
M7	11	-
M8	13	-
M10	17 (16) ¹⁾	-
M12	19 (18) ¹⁾	22
M14	22 (21) ¹⁾	-
M16	24	27
M18	27	-
M20	30	32

Größe	DIN 931 / 934 ~7990	DIN EN 14399
M22	32 (34) ¹⁾	36
M24	36	41
M27	41	46
M30	46	50
M33	50	-
M36	55	60
M39	60	-
M42	65	-
M45	70	-
M48	75	-
M52	80	-
M56	85	-
M60	90	-
M64	95	-

¹⁾ neue Schlüsselweite nach ISO





1

Schlitzmaße

Gewindeschrauben	M	2	2,5	3	3,5	4	5
Blechschauben	\emptyset	2,2T	2,2	2,9	3,5T	3,5 / 4,2T	4,2
Holz-/Spanplatten-schrauben	\emptyset	2	2,5	3	3,5	4 / 4,5	5
Kreuzschlitz H/Z	No	0/1	1	1/2	2	2	2
Innensechsrund	T	6	8	10	15	20	25



4

Gewindeschrauben	M		6	7	8	10
Blechschauben	\emptyset	4,8T / 5,5T	5,5 / 6,3		8	
Holz-/Spanplatten-schrauben	\emptyset	5,5	6	7	8	10
Kreuzschlitz H/Z	No	3	3	3	4	4
Innensechsrund	T	25	30		40	50



5



6

Mit T gekennzeichnete Durchmesser beziehen sich auf den Innensechsrundantrieb.



7

Neue Schlüsselweiten n. ISO 272

Gewindegröße	M10	M12	M14	M22
bisher	17	19	22	32
ISO 272	16	18	21	34



8

bisher DIN	wird ISO
555	4034
558	4018
601	4016
931	4014
933	4017
934	4032



9

Mutternhöhe	
DIN	0,8 d
ISO	0,9 d

Geometrie

Schlüsselweiten für Schrauben und Muttern mit Außenvierkant und -sechskant

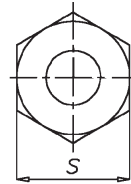
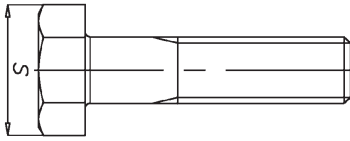

Gewinde	Sechskant klein	Sechskant Regel	Sechskant groß	Vierkant - Schrauben	Vierkant - Muttern
Beispiele für Produkt-normen	DIN 561 DIN 564	DIN 601 DIN 917 DIN 931 DIN 933 DIN 934	DIN EN 14399	DIN 478 DIN 479 DIN 480	DIN 557
M 1,6		3,2			
M 2		4			
M 2,5		5			
M 3		5,5			
M 4		7			
M 5		8		5	8
M 6	8	10		6	10
M 8	10	13		8	13
M 10	13	17 (16*)		10	17 (16*)
M 12	17 (16*)	19 (18*)	22 (21*)	13	19 (18*)
M 14		22 (21*)			
M 16	19 (18*)	24	27	17 (16*)	24
M 18		27			
M 20	24	30	32 (34*)	22 (21*)	30
M 22		32 (34*)	36		
M 24	30	36	41	24	
M 27		41	46		
M 30	36	46	50		
M 33		50	55		
M 36	46	55	60		

Schlüsselweiten für Schrauben und Muttern mit Außenvierkant und –sechskant



Gewinde	Sechskant klein	Sechskant Regel	Sechskant groß	Vierkant - Schrauben	Vierkant - Muttern
M 39		60	65		
M 42	55	65			
M 45		70			
M 48	65	75			
M 52		80			
M 56		85			
M 60		90			
M 64		95			
M 68		100			

Schlüsselweiten S in mm

* neue Schlüsselweiten nach ISO 272

Geometrie

Schlüsselweiten für Innensechskantschrauben,
Innensechskant - Gewindestifte und Stiftschlüssel

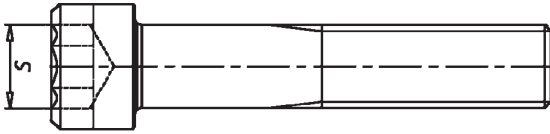

S	Zylinderkopf- schrauben	Gewindestifte	Zylinderkopf- schrauben niedriger Kopf	Senkkopf- schrauben
	z.B. DIN 912	z.B. DIN 914	z.B. DIN 7984	z.B. DIN 7991
0,7		M 1,4 - M 1,8		
0,9		M 2		
1,3	M 1,4	M 2,5		
1,5	M 1,6 - M 2	M 3		
2	M 2,5	M 4	M 3	M 3
2,5	M 3	M 5	M 4	M 4
3	M 4	M 6	M 5	M 5
4	M 5	M 8	M 6	M 6
5	M 6	M 10	M 8	M 8
6	M 8	M 12 - M 14	M 10	M 10
8	M 10	M 16	M 12	M 12
10	M 12	M 18 - M 20	M 14	M 16
12	M 14	M 22 - M 24	M 16 - M 18	M 20
14	M 16 - M 18		M 20 - M 22	M 24
17	M 20 - M 22		M 24	
19	M 24 - M 27			
22	M 30			
27	M 36			



DIN 1441			DIN 6340			DIN 7349		
I-Ø	A-Ø	H	I-Ø	A-Ø	H	I-Ø	A-Ø	H
						3,2	9	1
						4,3	12	1,6
5,5	10	0,8				5,3	15	2
			6,4	17	3	6,4	17	3
7	12	1,6						
8	14	1,6	8,4	23	4	8,4	21	4
9	15	2	10,5	28	4	10,5	25	4
11	20	2,5						
13	25	3	13	35	5	13	30	6
14	25	3						
15	28	3				15	36	6
17	28	3	17	45	6	17	40	6
19	30	4				19	44	8
21	32	4	21	50	6	21	44	8
23	34	4				23	50	8
24	36	4						
25	38	4	25	60	8	25	50	10
26	40	4						
27	40	5						
28	40	5				28	60	10
29	42	5						
31	45	5	31	68	10	31	68	10
34	50	5						
37	52	6						
41	58	6						
46	62	7						

I-Ø = Innendurchmesser
 A-Ø = Außendurchmesser
 H = Höhe

DIN 7989			DIN 9021			DIN 1052		
I-Ø	A-Ø	H	I-Ø	A-Ø	H	I-Ø	A-Ø	H
			2,7	8	0,8			
			3,2	9	0,8			
			3,7	11	0,8			
			4,3	12	1			
			5,3	15	1,2			
			6,4	18	1,6			
			7,4	22	2			
			8,4	24	2			
			10,5	30	2,5			
11	21	8						
14	24	8	13	37	3			
						14	58	6
			15	44	3			
			17	50	3			
18	30	8				18	68	6
			20	56	4			
22	37	8	22	60	4			
						23	80	8
24	39	8						
						25	92	8
26	44	8	26	72	5			
						27	105	8
30	50	8						
33	56	8	33	92	6			
36	60	8						
39	66	8	39	110	8			



I-Ø = Innendurchmesser
A-Ø = Außendurchmesser
H = Höhe



Festigkeitsklasse	3.6	4.6	4.8	5.6	5.8	8.8	10.9	12.9
Kennzeichen (Symbol)	3.6	4.6	4.8	5.6	5.8	8.8	10.9	12.9

Der Punkt zwischen den Zahlen darf entfallen. Bei Verwendung von Stahl mit niedrigem Kohlenstoffgehalt bei der Festigkeitsklasse 10.9 muss das Kennzeichen unterstrichen werden: 10.9. Die Festigkeitsklassen 6.8 und 9.8 sind in

Deutschland nicht üblich. Im Falle von kleinen Schrauben oder wenn die Kopfform eine solche Kennzeichnung nicht zulässt, darf eine Kennzeichnung nach dem folgenden Uhrzeigersystem angewendet werden.

	Festigkeitsklasse				
	3.6	4.6	4.8	5.6	5.8
Kennzeichnung der Festigkeitsklasse					

	6.8	Festigkeitsklasse				
		8.8	9.8	10.9	10.9	12.9

Uhrzeigersystem zur Kennzeichnung von Schrauben

- a Die 12 Uhr Position ist entweder durch das Herstellerzeichen oder durch einen Punkt festzulegen.
- b Die Festigkeitsklasse wird durch einen Strich oder Doppelstrich und im Falle von 12.9 durch einen Punkt gekennzeichnet.

Sechskantschrauben und Schrauben mit Außensechsrund

Schrauben (einschließlich Produkte mit Flansch) müssen ab Gewindedurchmesser M5 und ab Festigkeitsklasse 3.6 mit dem Symbol vorzugsweise auf dem Kopf gekennzeichnet sein. Weiter ist das Herstellerkennzeichen er-

forderlich. Die Kennzeichnung kann auf dem Kopf erhöht oder vertieft oder an den Schlüsselflächen vertieft angebracht sein. Bei Schrauben mit Flansch ist die Kennzeichnung auf dem Flansch anzubringen, sofern die Herstellung eine Kennzeichnung auf dem Kopf nicht zulässt.

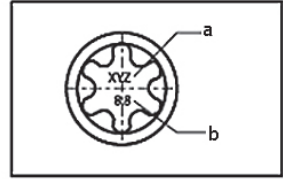
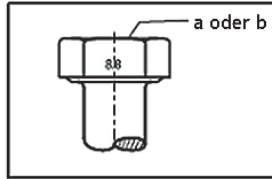
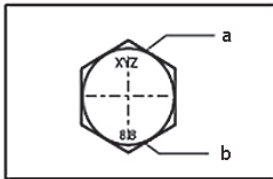

a = Herkunftszeichen

b = Festigkeitsklasse

Zylinderschrauben mit Innensechskant und Innensechsrund

Diese Schrauben müssen ab Gewindedurchmesser M 5 und ab der Festigkeitsklasse 8.8 mit einem entsprechenden Symbol gekennzeichnet sein, wo immer die Form der Schrau-

be eine Kennzeichnung zulässt. Vorzugsweise auf der Kopfoberfläche (erhöht oder vertieft) oder an der Zylinderfläche des Kopfes (vertieft). Weiter ist das Herstellerkennzeichen erforderlich.

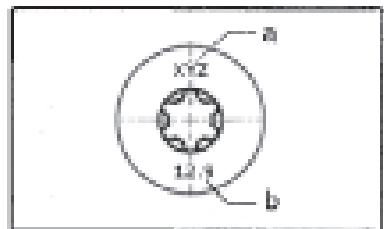
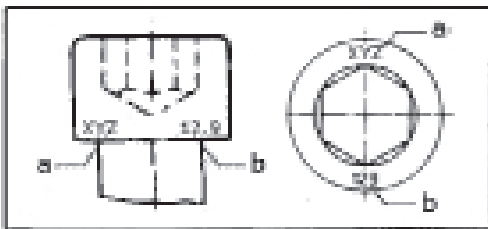

a = Herkunftszeichen

b = Festigkeitsklasse





1 Flachrundschrauben mit Vierkantansatz

Flachrundschrauben mit Vierkantansatz ab Gewindedurchmesser M5 und ab der Festigkeitsklasse 8.8 sind mit dem Herstellerzeichen und mit dem Kennzeichen der Festigkeitsklasse zu kennzeichnen. Sie ist auf dem Kopf vertieft oder erhöht anzubringen.

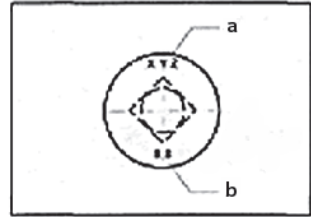

a = Herkunftszeichen

b = Festigkeitsklasse

5 Ringschrauben

Ringschrauben nach DIN 580 gelten nach der Maschinenrichtlinie 2006/42/EG als Lastaufnahme- und unterliegen entsprechenden sicherheitsrelevanten Anforderungen. Vor diesem Hintergrund wurde die Norm im Jahr 2008 umfassend, in Ausgabe 09-2010, überarbeitet.

Bestandteil dieser Anforderungen ist auch die erweiterte Kennzeichnungspflicht. Ringschrauben nach DIN 580, Ausgabe 09-2010 sind wie im nachfolgenden Beispiel gekennzeichnet. Zusätzlich kann eine Chargenkennzeichnung vorhanden sein.

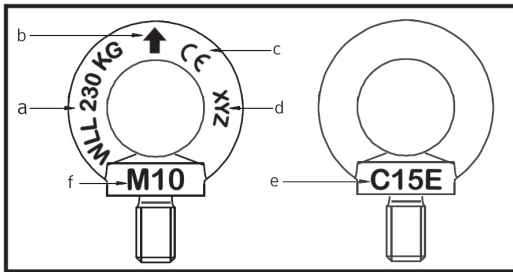

a = WLL (zulässige Tragfähigkeit, axial)

b = Richtung auf die sich die zulässige Tragfähigkeit bezieht.

c = CE-Kennzeichnung

d = Herstellkennzeichen

e = Werkstoff

f = Gewindegröße

Stiftschrauben

Stiftschrauben ab Gewindedurchmesser M5 und die Festigkeitsklasse 5.6 sowie 8.8 und höher müssen gekennzeichnet sein. Da relativ wenig Platz vorhanden ist, stehen neben der Kennzeichnung mit Zahlen auch noch andere Symbole zur Verfügung. Weiter ist das Herstel-

lerkennzeichen erforderlich. Die Kennzeichnung wird vertieft auf der Kuppe des Gewindes angebracht.

Bei Stiftschrauben mit Festsitzgewinde (Sn4, SK6) am Einschraubende muss das Kennzeichen der Festigkeitsklasse auf der Kuppe des Mutterendes aufgebracht sein.

Festigkeitsklasse	5.6	8.8	9.8*	10.9	12.9
Kennzeichnung	-	O	+	□	Δ

*In Deutschland ist die Festigkeitsklasse 9.8 nicht üblich

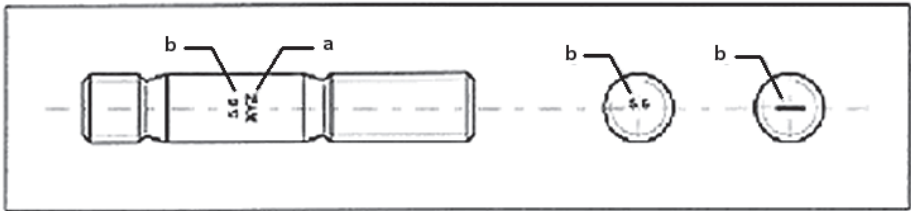

a = Herkunftszeichen

b = Festigkeitsklasse

Sechskantschrauben mit Linksgewinde

Diese Schrauben müssen durch ein Symbol (Pfeil) an verschiedenen Orten (Kopf oder Kuppe) oder dann durch eine Einkerbung über die Sechskantecken ab Gewindedurchmesser M5

gekennzeichnet sein. Bei anderen Arten von Schrauben mit Linksgewinde besteht keine Kennzeichnungspflicht.

Auch eine kopfseitige Kennzeichnung der Schrauben mit den Buchstaben Li ist üblich.

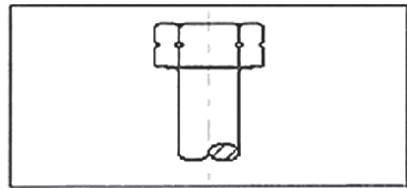
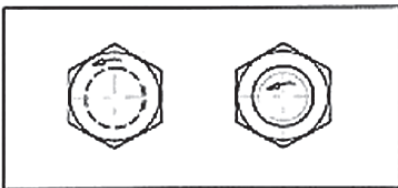



Kennzeichnung von Muttern

Sechskantmuttern ab M5 müssen mit der Festigkeitsklasse und dem Herstellerzeichen gekennzeichnet sein, sofern dies nicht technische Gründe ausschließen. Auf den Packungen sollen in jedem Fall die Festigkeitsklasse und das Herstellerkennzeichen stehen. Die Festigkeitsklasse 9 bei Muttern wird in anderen Ländern (z.B. USA) angewendet. Die Kennzeichnung

kann auf der Auflagefläche bzw. einer Schlüsselfläche vertieft oder auf der Fase erhöht angebracht sein. Der Kennzeichnungspunkt darf durch das Herstellerzeichen ersetzt werden, wenn die Kennzeichnung auf der Auflagefläche erfolgt. Die Kennzeichnung der Mutter mit Symbol oder Festigkeitsklasse bleibt dem Hersteller freigestellt.

Festigkeitsklasse	4	5	6	8
wahlweise Kennzeichen der Festigkeitsklasse	4	5	6	8
oder Symbol der Festigkeitsklasse (Uhrzeigersinn)				

Festigkeitsklasse	9	10	12 ^{*)}
wahlweise Kennzeichen der Festigkeitsklasse	9	10	12
oder Symbol der Festigkeitsklasse (Uhrzeigersinn)			
*) der Kennzeichnungspunkt kann nicht durch das Herstellerkennzeichen ersetzt werden			

Festigkeitsklasse	04	05
Kennzeichen der Festigkeitsklasse		

Sechskantmuttern mit Linksgewinde

Diese Muttern müssen auf der Auflagefläche vertieft oder durch Einkerbung gekennzeichnet sein. Diese Kennzeichnung ist ab M5 vorgeschrieben.

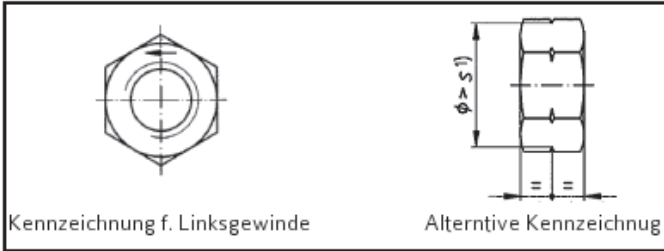

Ringmuttern

Ringmuttern nach DIN 582 gelten nach der Maschinenrichtlinie 2006/42/EG als Lastaufnahmemittel und unterliegen entsprechenden sicherheitsrelevanten Anforderungen. Vor diesem Hintergrund wurde die Norm im Jahr 2008 umfassend, in Ausgabe 09-2010, überarbeitet.

Bestandteil dieser Anforderungen ist auch die erweiterte Kennzeichnungspflicht. Ringmuttern nach DIN 582, Ausgabe 09-2010 sind wie im nachfolgenden Beispiel gekennzeichnet. Zusätzlich kann eine Chargenkennzeichnung vorhanden sein.

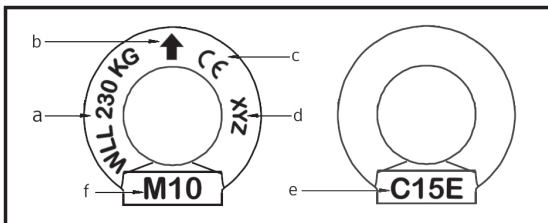

a = WLL (zulässige Tragfähigkeit, axial)

b = Richtung auf die sich die zulässige Tragfähigkeit bezieht.

c = CE-Kennzeichnung

d = Herstellkennzeichen

e = Werkstoff

f = Gewindegröße





1

Kennzeichnung von Schrauben aus nichtrostenden Stählen

Diese Schrauben müssen ab M5 gekennzeichnet sein. Die Kennzeichnung muss die Stahlgruppe und die Festigkeitsklasse sowie das Herstellzeichen enthalten, sofern nicht technische Gründe dieses ausschließen.

Kohlenstoffgehalt von höchstens 0,03% dürfen zusätzlich mit dem Buchstaben L gekennzeichnet sein.

Die Kennzeichnung ist verbindlich vorgeschrieben, zusätzliche Kennzeichen dürfen angebracht werden, sofern dies nicht zu Verwechslungen führt.



2



3

Nichtrostende Stähle mit niedrig legiertem



4

Kennzeichnung von Sechskantschrauben

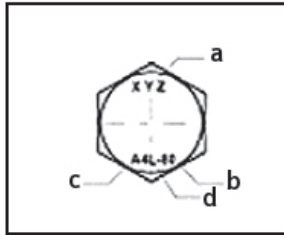
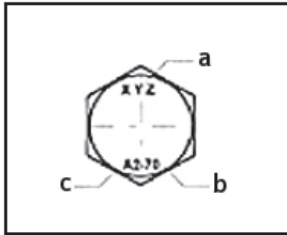

a = Herkunftszeichen

b = Festigkeitsklasse

c = Stahlsorte

d = Kohlenstoffgehalt max. 0,03%



5



6



7



8

Kennzeichnung von Zylinderschrauben mit Innensechskant und Innensechsrund

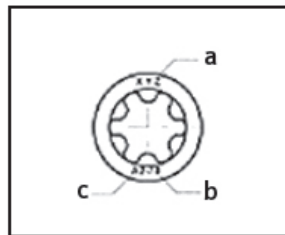
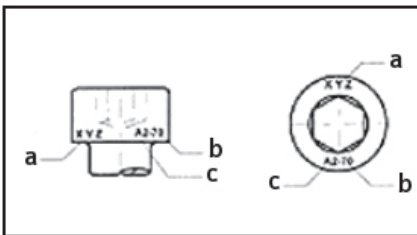

a = Herkunftszeichen

b = Festigkeitsklasse

c = Stahlsorte



9

Kennzeichnung von Stiftschrauben aus nichtrostenden Stählen

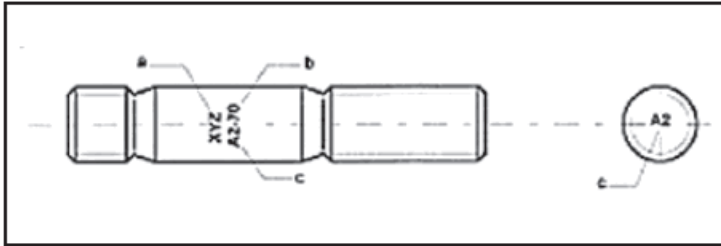

a = Herkunftszeichen

b = Festigkeitsklasse

c = Stahlsorte

1



2



3



4



5



6



7



8



9





Kennzeichnung von Muttern aus nichtrostenden Stählen

Muttern mit einem Gewinde-Ne Nenndurchmesser ab M5 sind mit der Stahlgruppe, dem Herstellerzeichen und der Festigkeitsklasse zu kennzeichnen, soweit dies technisch möglich ist.

Die Kennzeichnung auf der Auflagefläche oder der Schlüsselfläche ist zulässig und darf nur vertieft angebracht sein. Nichtrostende Stähle mit niedrigem Kohlenstoffgehalt von höchstens 0,03% dürfen mit dem Buchstaben L gekennzeichnet sein.

Muttern Typ 1

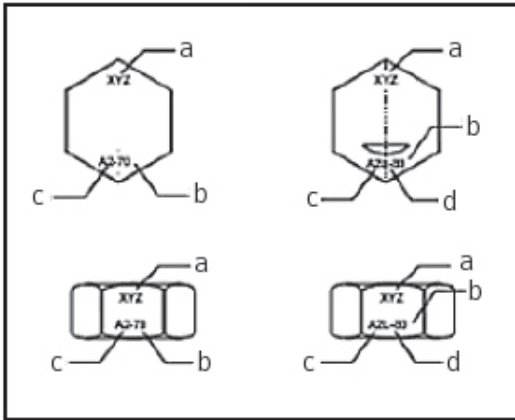

Niedrige Muttern

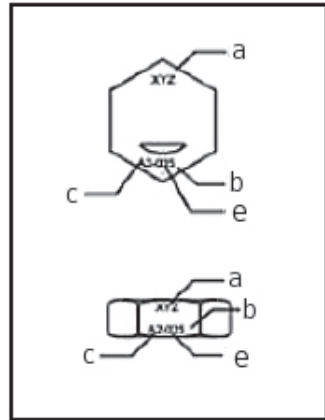

a = Herkunftszeichen

b = Festigkeitsklasse

c = Stahlsorte

d = Kohlenstoffgehalt max. 0,03%

e = Hinweis auf geringe Belastbarkeit

Die Bezeichnung der Festigkeitsklasse bei Muttern (Typ1) 0,8 d und größer, besteht aus 2 Ziffern die 1/10 der Prüfspannung entspricht. Beispiel: A2-70

mit 3 Ziffern angegeben, wobei die erste Ziffer auf die geringere Belastbarkeit hinweist und die folgenden Ziffern 1/10 der Prüfspannung angeben. Beispiel: A2-035

Bei niedrigen Muttern (einschließlich 0,5 d) jedoch geringer 0,8 d wird die Festigkeitsklasse

Nur die Stahlgruppe A2 und A4 sind mit Rillen zu kennzeichnen. Sind die Festigkeitsklassen nicht angegeben, dann gilt die Festigkeitsklasse 50 bzw. 025.

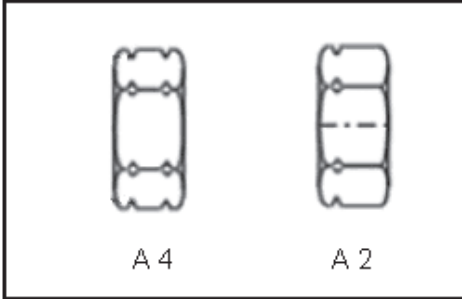



1 HV-Garnituren

HV-Garnituren müssen neben der Kennzeichnung der Festigkeitsklasse und dem Herstellerkennzeichen zusätzlich die HV-Kennzeichnung tragen. Für HV-Garnituren ist eine eindeutige Zuordnung zum Abnahmeprüfzeugnis 3.1 (falls

gefordert) über folgende Kombination möglich:

- Seriennummer
- Durchmesser der Schraube
- Länge der Schraube

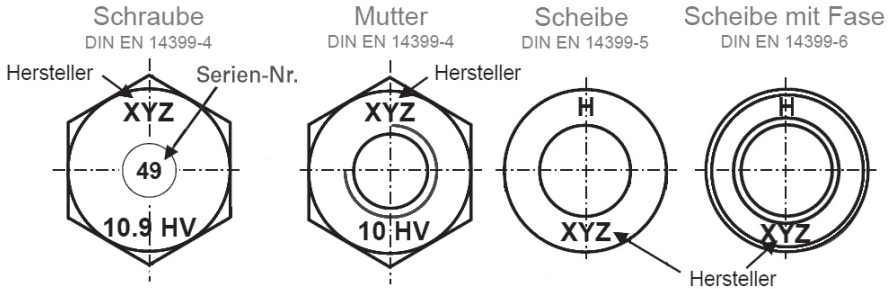

6 SB-Garnituren

SB-Garnituren müssen neben der Kennzeichnung der Festigkeitsklasse und dem Herstellerkennzeichen zusätzlich die SB-Kennzeichnung tragen.

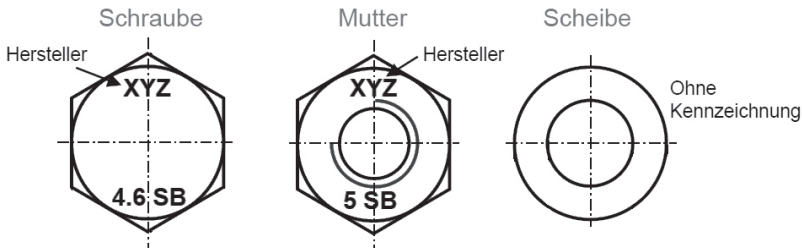

Wie durch die EN1090-2 vorgegeben, muss der Hersteller von Stahlbaukonstruktionen Erzeugnisse (z.B. Schraubengarnituren) mit den entsprechenden Prüfbescheinigungen beziehen, die Zuordnung zu Bauteilen oder Bauwerk vornehmen und dokumentieren. Dies dient der Identifikation und Rückverfolgbarkeit.

gefordert werden. Bei Garnituren für Schraubenverbindungen (HV- und SB-Garnituren) kann nach EN1090 auf eine Werksbescheinigung verzichtet werden, wenn diese Produkte mit einer Seriennummer (Chargenkennzeichen) versehen sind.

Bei der Beschaffung muss vom Lieferanten eine Prüfbescheinigung 2.1 nach EN10204 an-

CE-Kennzeichen

Mit der CE-Kennzeichnung erklärt der Hersteller, Inverkehrbringer oder EU-Bevollmächtigte gemäß EU-Verordnung 765/2008, „dass das Produkt den geltenden Anforderungen genügt, die in den Harmonisierungsrechtsvorschriften der Gemeinschaft über ihre Anbringung festgelegt sind.“ Es ist damit eine Art Warenpass für den Warenverkehr.

Für diese Produkte muss auch eine Leistungserklärung erstellt werden.

Im Sinne der Bauproduktenrichtlinie (CPD) sind alle Produkte bzw. Komponenten, die hergestellt werden, um dauerhaft in Bauwerken des Hoch- und Tiefbaues eingebaut zu werden, CE-kennzeichnungspflichtig. Hierzu zählen auch Verbindungselemente.

Die Richtlinie sieht vor, dass die Begleitpapiere oder Verpackungen mit dem CE-Kennzeichen zu kennzeichnen sind. Die Kennzeichnung der Verbindungselemente selbst ist jedoch nicht gefordert.

Insbesondere bei Verbindungselementen mit metrischen Gewinden ist zu beachten auf Basis welcher harmonisierten europäischen Norm die CE-Kennzeichnung erfolgt ist. Der zugelassene Verwendungszweck ist in der Leistungserklärung und zukünftig auch auf der CE-Kennzeichnung anzugeben.

1



2



3



4



5



6



7



8



9





1

Schraubenlinie:

Eine Schraubenlinie entsteht, wenn auf der Mantelfläche eines sich drehenden Zylinders ein Punkt gleichförmig in Richtung der Zylinderachse bewegt wird. Die Längsverschiebung des Punktes bei einer Umdrehung entspricht der Steigung eines Gewindes.

Der vom Umfang und von der Schraubenlinie eingeschlossene Winkel ist der Steigungswinkel des Gewindes.



2

Gewindemerkmale:

Die Gewinde unterscheiden sich nach Verwendungszweck, Profil, Gangzahl und Gangrichtung (Drehrichtung).

Die Abwicklung der Mantelfläche unterhalb der Schraubenlinie ergibt ein rechtwinkliges Dreieck.



3

Gewindeprofil:

Das Gewindeprofil wird als Spitz-, Trapez-, Sägen- und Rundgewinde sowie Sondergewinde bezeichnet.



4

Gewindegänge:

Nach der Gangzahl unterscheidet man zwischen ein- oder mehrgängigen Gewinden. Als Befestigungsgewinde werden überwiegend eingängige, für Bewegungsgewinde ein- oder mehrgängige Gewinde verwendet.

Ein Gewinde hat so viele Gänge, wie es Gewindeanfänge besitzt. Mehrgängige Schrauben werden eingesetzt, um insbesondere schnelleren Vortrieb und höhere Abzugskräfte zu erreichen (z.B. Schnellbauschrauben).



5

Drehrichtung:

Linksgewinde müssen mit den Buchstaben „LH (Left Hand)“ in Zeichnungen, auf Stücklisten und in Bestellungen angegeben werden, z.B. M 20 X 1,5 – LH.

Die Gewinde werden nach ihrer Drehrichtung beim Einschrauben bezeichnet: Rechtsgewinde (Regelfall) bzw. Linksgewinde.



6

Verwendungszweck:

Nach dem Verwendungszweck unterscheidet man zwischen Befestigungs- und Bewegungsgewinde. Als Befestigungsgewinde dienen vorwiegend Spitzgewinde.

Die Bewegungsgewinde (meist Trapezgewinde) wandeln Drehbewegungen in Längsbewegungen um.



7



8



9

Gewindemaße:

Das Gewinde wird durch fünf Größen festgelegt: Außendurchmesser, Kerndurchmesser, Steigung, Flankendurchmesser und Flankenwinkel.

Außendurchmesser:

auch Nenndurchmesser. Der achsensenkrechte Abstand der äußersten Punkte des Gewindes.

Kerndurchmesser:

Der Abstand der innersten Punkte des Gewindes.

Steigung (P):

früher Ganghöhe. Der achsparallele Abstand zweier benachbarter gleichgerichteter Gewindeflanken desselben Gewindeganges.

Bei metrischen Gewinden der Weg, der durch eine Umdrehung zurückgelegt wird in mm.

Flankendurchmesser:







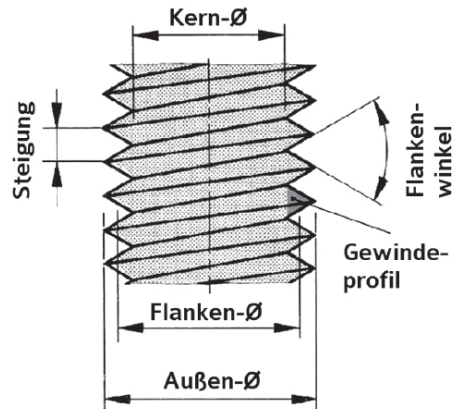

Der achsensenkrechte Abstand zweier gegenüberliegender Gewindeflanken.

Die Abkürzungen der Gewindemaße am Muttergewinde werden mit großen Buchstaben, die am Schraubengewinde mit kleinen Buchstaben angegeben.

Flankenwinkel:

Der von den Gewindeflanken eingeschlossene Winkel.



	Benennung	Kurzzeichen Beispiel	Anwendung	Nach Norm
	M Metrisches ISO Regelgewinde	M 0,8	Uhren und Feinwerkmechanik (M < 1mm)	DIN 14-1 bis -4
		M 30	Regelgewinde (M > 1mm)	DIN 13-1
	Metrisches ISO Feingewinde	M20X1	Allgemein, wenn die Steigung des Regelgewindes zu groß	DIN 13-2 bis -11
	Metrisches ISO Linksgewinde	M20X1-LH	Allgemein, wenn die Steigung des Regelgewindes zu groß	DIN 13-2 bis -11
	Metrische ISO Gewinde mit Übergangstoleranzfeld (früher Gewinde mit Festsitz)	M10 Sn 4 M10 Sk 6	Für Einschraubende an Stiftschrauben (nicht-dichte Verbindung)	DIN 13-51
	Metrisches Gewinde mit großem Spiel	M10 Sn4 dicht	Für Einschraubende an Stiftschrauben (dichte Verbindung)	DIN 13-51
		DIN 2510 M36	Für Schraubverbindungen mit Dehnschaft	DIN 2510-2
	M Metrisches kegeliges Außengewinde	DIN 158 M30X2 keg	Für Verschlusschrauben und Schmiernippel (Regelausführung)	DIN 158
		DIN 158 M30X2 keg kurz	Für Verschlusschrauben und Schmiernippel (Kurzausführung)	DIN 158
	Tr Metrisches ISO Trapez-Gewinde, ein und mehrgängig	Tr 40 X 7	eingängig	DIN 103-1 bis 8
		Tr 40 X 14 P7	mehrgängig	DIN 103-1 bis 8
	Rd Zylindrisches Rundgewinde, ein und mehrgängig	Rd 40X1/6	eingängig	DIN 405 -1 u. 2
		Rd 40x1/3 P 1/6	mehrgängig	DIN 405 -1 u. 2

Benennung	Kurzzeichen Beispiel	Anwendung	Nach Norm
G Zylindrisches Rohrgewinde für Nichtdichtende Verbindungen	G 1 1/2 A	Außengewinde für Rohr und Rohrverbindungen (enge Toleranzklasse)	DIN ISO 228-1 und -2
	G 1 1/2 B	Außengewinde für Rohr und Rohrverbindungen (weite Toleranzklasse)	DIN ISO 228-1 und -2
	G 1 1/2	Innengewinde für Rohr und Rohrverbindungen	DIN ISO 228-1 und -2
R Zylindrisches Rohrgewinde für Nichtdichtende Verbindungen		Für Rohre und Rohrverbindungen „Nicht für Neukonstruktionen!“ Ersetzt durch DIN ISO 228-1-3	Z-DIN 259 1-3
	Kegeliges Rohrgewinde für im Gewinde dichtende Verbindungen	DIN EN 10266-1-R1/2	Außengewinde für Gewinderohre und Fittings
	DIN 3858 R1/8-1	Außengewinde für Rohrverschraubungen	DIN 3858
Rp Zylindrische Rohrgewinde für im Gewinde dichtende Verbindungen	DIN EN 10226-1-R1/2	Innengewinde für Gewinderohre und Fittings	DIN EN 10226-1
	DIN 3858-Rp1/8	Innengewinde für Rohrverschraubung	DIN 3858
ST Blechschraubengewinde	DIN 7970-ST 3,5	Für Blechschrauben	ISO 1478
- Holzschraubengewinde	DIN 7998-4	Für Holzschrauben	DIN 7998





Nennmaß:

Das in der Zeichnung oder Norm vorgegebene Maß.



Istmaß:

Das bei der Fertigung erzielte, tatsächliche Maß.



Toleranz:

Die Toleranz gibt die zulässige Abweichung vom Nennmaß an. Eine Toleranz ist gekennzeichnet durch die Breite (Genauigkeitsgrad) und die Lage des Toleranzfeldes.



Abmaße:

Das obere Abmaß (A0) und das untere Abmaß (Au) geben die Grenzen der erlaubten Maßabweichung bezogen auf das Nennmaß an. „Unten“ und „oben“ bezieht sich sowohl bei Schrauben als auch bei Muttern auf die Mittellinie.



Toleranzlagen:

Durch die Toleranzlage wird der Abstand des Toleranzfeldes vom Nennmaß festgelegt. Die verschiedenen Toleranzlagen sind durch Kleinbuchstaben für Bolzengewinde und durch Großbuchstaben für Mutterngewinde festgelegt.



Toleranzsysteme:

Das Toleranzsystem für die metrischen ISO-Gewinde (DIN 13-14 / ISO 965-1 bis -3 u.a.) beschreibt die Breite und Lage von Toleranzfeldern von Gewindemaßen.



Toleranzfeld:

Bereich zwischen oberem und unterem Abmaß. Die Toleranzfelder für handelsübliche Schrauben und Muttern sind so gewählt, dass die Spiele ohne weiteres zum Aufbringen von Schutzüberzügen ausreichen ohne dass die

Grenzmaße:

Die Grenzmaße (Größtmaße und Kleinstmaße) geben die absoluten Zahlenwerte an, innerhalb derer das tatsächliche Maß liegen muss.



Gängigkeit beeinträchtigt wird. Siehe folgende Tabelle. Auf Gängigkeit werden blanke Schraubengewinde mit 6g, verzinkt Schraubengewinde mit 6h Ringlehren geprüft.



Mutter	Bolzen	Oberflächenzustand nach ISO 965
6 H	6 g	blank, phosphatiert, dünne galv. Schutzschicht
6 G	6 e	blank (mit großem Spiel), sehr dicke galv. Schutzschicht

Toleranzklassen:

Abhängig von der Verwendung von Schraubenverbindungen werden die Gewindetoleranzen in 3 Klassen eingeteilt:

fein: Präzisionsgewinde, wenn nur kleine Variationen im Passcharakter erlaubt sind

mittel: Allgemeine Verwendung

grob: Wenn keine besondere Genauigkeitsanforderung besteht, bzw. wenn Fertigungsschwierigkeiten auftreten können.

Einschraublänge:

Bei der Fertigung können sich Form-, Lage- und Steigungsabweichungen mit zunehmender Länge von Gewindeteilen kumulieren. Dies führt dazu, dass bei Paarungen von Innen- und Außengewinde mit wachsender Einschraublänge auch die Unterschiede der Flankendurchmesser zunehmen und damit der Einschraubvorgang durch erhöhte Reibkräfte erschwert bzw. unmöglich wird.

Schraubenverbindungen werden entsprechend ihrer Einschraublänge 3 verschiedenen Gruppen zugeordnet (Siehe folgende Tabelle):

S Einschraublänge kurz (short)

N Einschraublänge normal (normal)

L Einschraublänge lang (long)

Regelgewinde	P	Einschraublängen					
		S		N		L	
		bis	über	bis	über		
M 3	0,5	1,5	1,5	4,5	4,5		
M 4	0,7	2	2	6	6		
M 5	0,8	2,5	2,5	7,5	7,5		
M 6	1	3	3	9	9		
M 8	1,25	4	4	12	12		
M 10	1,5	5	5	15	15		
M 12	1,75	6	6	18	18		
M 16	2	8	8	24	24		
M 20	2,5	10	10	30	30		
M 24	3	12	12	36	36		
M 30	3,5	15	15	45	45		
M 36	4	18	18	53	53		





Gewinde		Steigung P für metrisches Gewinde M				Steigung P für Trapezgewinde Tr		
M	Tr	Regel	Fein	Fein2	extra fein	Grob	Regel	Fein
	1	0,25						
	1,2	0,25						
	1,4	0,3						
	1,6	0,35						
	1,8	0,35						
	2	0,4						
	2,2	0,45						
	2,5	0,45						
	3	0,5						
	3,5	0,6						
	4	0,7						
	5	0,8						
	6	1						
	8	1,25	1				1,5	
	10	1,5	1		0,75		2	1,5
	12	1,75	1,5	1,25	1		3	2
	14	2	1,5		1		3	2
	16	2	1,5		1		4	2
	18	2,5	1,5		1		4	2
	20	2,5	1,5		1		4	2
	22	2,5	1,5		1	8	5	3
	24	3	2		1,5	8	5	3
	27	26/28	2		1,5	8	5	3
	30	30	2		1,5	10	6	3
	33	32/34	2		1,5	10	6	3
	36	36	3		1,5	10	6	3
	39	38/40	3		1,5	10	7	3
	42	42	3		1,5	10	7	3
	45	44(46)	3		1,5	12	7(8)	3
	48	48	3		1,5	12	8	3

Gewinde		Gewindesteigung P				Trapezgewindesteigung Tr		
M	Tr	Regel	Fein	Fein2	extra fein	Grob	Regel	Fein
52	50/52	5	3		2	12	8	3
56	55	5,5	4		2	14	9	
60	60	5,5	4		2	14	9	3
64	65	6	4		2	16	10	4
68	70	6	4		2	16	10	4
M72 bis M150			6	4	2			





1

DIN EN ISO 8044 (ehemals DIN 50900) definiert Korrosion als die Reaktion eines metallischen Werkstoffes mit seiner Umgebung, die eine messbare Veränderung des Werkstoffes bewirkt und zu einer Beeinträchtigung der Funktion eines metallischen Bauteiles oder eines ganzen Systems führen kann.



2

Korrosion ist unvermeidbar. Man muss mit der Korrosion leben, indem man Ihre verschiedenen Erscheinungsformen kontrolliert.



3

Korrosion verursacht eine messbare Veränderung der Werkstoffeigenschaften und beeinträchtigt die Funktion der Verbindungselemente



4

Das Korrosionsgeschehen wird beeinflusst durch:

- den Werkstoff
- die Umgebungsbedingungen
- die möglichen Reaktionen



5

Der Mechanismus ist einfach:



6

Sauerstoffarme, feuchte Oberflächenbezirke entwickeln anodische Eigenschaften gegenüber sauerstoffreichen kathodischen Bezirken.



7

Im Feuchtigkeitsfilm fließt ein Korrosionsstrom von der Anode zur Kathode und transportiert Metallionen. Auf dem Weg zur Kathode reagieren diese mit Wasser und Sauerstoff zu Rost.



8

Rost entsteht somit, wenn:

- Feuchtigkeit vorhanden ist
- Schlecht belüftet Bereiche vorhanden sind
- Korrosionsstrom fließen kann



9

Konstruktive Gegenmaßnahmen:

- Teile gut belüften
- Feuchtigkeit/Wasser rasch abfließen lassen
- Korrosionsströme / Stromdichten minimieren

Im Folgenden werden die wichtigsten Korrosionsarten beschrieben:

Flächenkorrosion

Die Flächenkorrosion wird durch Kontakt mit der Atmosphäre oder mit konzentrierten Säuren veranlasst.

Spaltkorrosion

Örtlich verstärkte Korrosion in Spalten, die entweder im Werkstoff selbst oder durch

Fügen mit anderen Bauelementen entstehen kann, z. B. unter Schraubenköpfen.

Kontaktkorrosion (Galvanische Korrosion)

Korrosion durch Berührung verschiedener Legierungen mit ausreichendem elektrischen Potential und Anwesenheit eines Elektrolyten. Deshalb sollen Schrauben und Muttern aus dem gleichen Metall bestehen wie die zu verbindenden Materialien. (siehe Tabelle)

Interkristalline Korrosion (Korrosion zwischen Metallkristallen)

Hier handelt es sich um einen nur auf einer bestimmten Stelle wirkenden Korrosionsangriff auf die korngrenznahe Bereiche. Dieser kann bis zum Zerfall des Gefüges in einzelne Körner führen.

Spannungsrissskorrosion

Korrosion und Dehnung des Metalls als Folge innerer oder aufgebrachtener Zugspannungen führen zu Rissbildung.

Weitere Korrosionsarten sind:

Transkristalline Korrosion, Lochkorrosion, Reibkorrosion, Spannungsrissskorrosion.

Hinsichtlich Kontaktkorrosion betrachteter Werkstoff	Flächenverhältnis	Werkstoff												
		Magnesium-Legierung	Zink	Feuerverzinkter Stahl	Aluminium Legierung	Cadmiumüberzug	Baustahl	Niedriglegierter Stahl	Stahlguss	Chromstahl	Blei	Zinn	Kupfer	Nichtrostender Stahl
Magnesium-Legierung	klein	S	S	S	S	S	S	S	S	S	S	S	S	S
	groß	M	M	M	M	S	S	S	S	S	S	S	S	S
Zink	klein	M	G	M	M	S	S	S	S	S	S	S	S	S
	groß	G	G	G	G	G	G	G	G	G	G	G	G	G
Feuerverzinkter Stahl	klein	M	G	M	M	S	S	S	S	S	S	S	S	S
	groß	G	G	G	G	G	G	G	G	G	G	G	G	G
Aluminium Legierung	klein	M	G	G	G	M	G	S	M	S	S	S	S	S
	groß	G	M	M	G	G	G	M	M	S	S	S	M	M
Cadmiumüberzug	klein	G	G	G	G	S	S	S	S	S	S	S	S	S
	groß	M	G	M	G	G	G	G	G	G	G	G	G	G
Baustahl	klein	G	G	G	G	G	M	S	S	S	S	S	S	S
	groß	G	G	G	G	G	G	G	G	G	G	G	G	G
Niedriglegierter Stahl	klein	G	G	G	G	G	G	M	S	S	S	S	S	S
	groß	G	G	G	G	G	G	G	G	G	G	G	G	G
Stahlguss	klein	G	G	G	G	G	M	S	S	S	S	S	S	S
	groß	G	G	G	G	G	G	G	G	G	G	G	G	G
Chromstahl	klein	G	G	G	G	G	G	G	M	M	S	S	S	S
	groß	G	G	G	G	G	G	G	G	G	G	G	G	G
Blei	klein	G	G	G	G	G	G	G	G	G	G	G	G	G
	groß	G	G	G	G	G	G	G	M	G	G	G	G	G
Zinn	klein	G	G	G	G	G	G	G	G	M	G	G	G	G
	groß	G	G	G	G	G	G	G	G	M	G	G	G	G
Kupfer	klein	G	G	G	G	G	G	G	M	M	S	S	S	S
	groß	G	G	G	G	G	G	G	G	G	M	M	G	G
Nichtrostender Stahl	klein	G	G	G	G	G	G	G	G	G	G	G	G	G
	groß	G	G	M	G	G	G	G	G	M	M	M	G	G

S = starke Korrosion des betrachteten Werkstoffs

M = mäßige Korrosion des betrachteten Werkstoffs

G = geringfügige oder keine Korrosion des betrachteten Werkstoffs



1



Verhinderung der Korrosion

Die durch chemische Einwirkungen (z. B. bei der Flächenkorrosion) verursachte Korrosion kann unterbunden werden, indem man den Zutritt von Sauerstoff und anderen angreifenden Stoffen verhindert.

2



Bei der elektrochemischen Korrosion (z. B. Kontaktkorrosion) müssen die Werkstücke gegen Elektrolyte abgeschirmt werden.

3



Korrosionsschutz durch Überzüge

Bei Fragen des Korrosionsschutzes ist es notwendig, alle Einflüsse an der Einbaustelle zu erfassen und dafür die richtige Lösung zu suchen. Besonders in der Verbindungstechnik reicht es oft aus, Schrauben und Muttern aus unlegierten oder niedriglegierten Stählen durch einen schützenden Überzug von den Angriffsmedien zu trennen.

4



5



Dabei muss berücksichtigt werden, dass die Wirksamkeit einer Schutzschicht von diversen Faktoren abhängig sein kann:

6



- Schutzschichtdicke
- Wahl des richtigen Überzugmetalls
- Aufbringungs- und Nachbehandlungsart (auch Qualität)
- Mechanische Beanspruchung der Schutzschicht

7



8



9



Nichtmetallische Überzüge

Diese Überzüge wurden meistens nur dort eingesetzt, wo sehr wenig aggressive Medien in den Atmosphären vorhanden sind. Außerdem dienen sie sehr oft als Unterstützung bei einem metallischen Überzug (Chromatieren), damit die noch vorhandenen Poren geschlossen werden können.

- **Einölen**
auftragen von säurefreien Ölen
- **Brünieren**
oxidieren durch Tauchen in Brünierbädern
- **Passivieren**
chem. Tauchverfahren in stromlosen, chromsäurehaltigen Bädern

Galvanische Überzüge

Der häufigste metallische Überzug ist die galvanische Verzinkung, bei der durch nachträgliches Chromatieren die Korrosionsschutzwirkung noch wesentlich erhöht werden kann. Die Schichtdicken bei galvanisch verzinkten Verbindungselementen liegen je nach Durchmesser zwischen 3 und 12 µm.

Vernickeln

Dieses Verfahren wird sehr häufig in der Elektroindustrie bei Stahl- und insbesondere bei Messing-Verbindungselementen als Oberflächenschutz angewendet. Ein vorhergehendes Unterkupfern der Teile erhöht die Haftfestigkeit.

Verchromen

Dieses Verfahren kommt in der Verbindungstechnik immer seltener vor. Heute wird es hauptsächlich dort angewendet, wo Verbindungsteile auch noch dekorative Zwecke erfüllen müssen. Wir unterscheiden:

- Verchromung matt
- Verchromung glänzend (erhöht die Anlaufbeständigkeit)
- Verchromung poliert (sehr teuer, Teile werden vor dem Verchromen von Hand poliert)





1 Galvanische Überzüge

Der häufigste metallische Überzug ist die galvanische Verzinkung. Dabei handelt es sich um ein elektrolytisches Metallabscheiden in galvanischen Bädern.

Die Korrosionsschutzwirkung kann durch nachträgliche Chromatieren noch wesentlich erhöht werden.

Die Kurzbezeichnung für galvanische Überzüge kann nach zwei verschiedenen Schlüsseln erfolgen:

Bezeichnung nach ISO 4042 – Anhang B

Bsp.: ISO 4014 - M 16 x 60 - 8.8 **gal Zn 5 c 2C**

- Art des Überzugsmetalle Zn = Zink
- Art der Aufbringung des Überzugsmetalle gal = galvanisch
- Mindest-Schichtdicke des Überzugsmetalle 5 = 5 µm (effektive Angabe!)

- c bezeichnet die Chromatierung
- 2 Klasse der Chromatierung
- Verfahrensgruppe des Chromatierens C = gelbfarbig

Kurzbezeichnung für galvanische Überzüge nach ISO 4042 – Anhang E

Beispiel: ISO 4014 - 8.8 - **A2C** - M16x60

- Kennbuchstabe für Überzugsmetall A = Zink
- Kennzahl für Schichtdicke und Schichtaufbau 2 = 5 µm (verschlüsselte Angabe)
- Glanzgrad und Nachbehandlung des Chromatierens C = gelbfarbig

Auf den folgenden Seiten findet man in Tabellenform die Zuordnung der Kennzahlen / Kennbuchstaben.

Überzugsmetall	Kurzzeichen	Kennbuchstabe
Zink	Zn	A
Cadmium	Cd	B
Kupfer	Cu	C
Kupfer Zink (Messing)	CuZn	D
Nickel	Ni b	E
Nickel-Chrom *	Ni b Cr r	F
Kupfer-Nickel	CuNi b	G
Kupfer-Nickel-Chrom *	CuNi b Cr r	H
Zinn	Sn	J
Kupfer-Zinn	CuSn	K
Silber	Ag	L
Kupfer-Silber	CuAg	N
Zink-Nickel	ZnNi	P
Zink-Kobalt	ZnCo	Q
Zink-Eisen	ZnFe	R

Kennzahl	Schichtdicke (Schichtaufbau) in µm	
	ein Überzugsmetall	zwei Überzugsmetalle
0	Keine Schichtdicke vorgeschrieben	-
1	3	-
2	5	2 + 3
3	8	3 + 5
4	12	4 + 8
5	15	5 + 10
6	20	8 + 12
7	25	10 + 15
8	30	12 + 18
9	10	4 + 6

Kennbuchstabe	Glanzgrad	Eigenfarbe der Chromatschicht
A	matt	keine
B	matt	bläulich bis bläulich irisierend
C	matt	gelblich bis gelbbraun irisierend
D	matt	olivgrün bis olivbraun
E	blank	keine
F	blank	bläulich bis bläulich irisierend
G	blank	gelblich bis gelbbraun irisierend
H	blank	olivgrün bis olivbraun
J	glänzend	keine
K	glänzend	bläulich bis bläulich irisierend
L	glänzend	gelblich bis gelbbraun irisierend
M	glänzend	olivgrün bis olivbraun
N	hochglänzend	keine Farbe
P	beliebig	wie Verfahrensgruppe B, C, D
R	Matt	braunschwarz bis schwarz
S	Blank	braunschwarz bis schwarz
T	Glänzend	braunschwarz bis schwarz
U	alle Glanzgrade	ohne Chromatieren





1

Warnvermerk Wasserstoffversprödung:
Bei galvanischen Überzügen auf hochfesten/einsatzgehärteten Teilen mit Zugfestigkeit ab ca. 1000N/mm² (Kern- oder Oberflächenhärten über 320 HV) und federharten Teilen mit Härten über 390 HV ist bei den bekannten Verfahren die Gefahr einer Wasserstoffversprödung nicht mit Sicherheit auszuschließen; sie kann durch Tempern vermindert aber nicht ausgeschlossen werden (siehe DIN EN ISO 4042, Abs. 6 und Anhang A).



2



3



4

Wenn die Vorbehandlung entsprechend den Vorgaben der ISO 10683 erfolgt, kann bei den folgenden Überzugsverfahren die Gefahr der Wasserstoffversprödung mit ausreichender Sicherheit ausgeschlossen werden.



5

Voraussetzung ist, dass der Verfahrensablauf zeittaktgesteuert komplett nach Vorschrift durchgeführt wird – einschließlich vorschriftsmäßiger Vorbehandlung/Reinigung der Teile. Erfahrungsgemäß tritt die Wasserstoffversprödung hauptsächlich bereits in diesem Beizvorgang auf.



6



7

Zinklamellenüberzüge nach DIN EN ISO 10683



8

Diese Beschichtung wird wie eine herkömmliche Farbe im Tauchverfahren angebracht, anschließend geschleudert und eingebrannt. Sie besitzen neben der Sicherheit gegen Versprödung hervorragende Korrosionsschutzeigenschaften. Über das Beifügen von Gleitmitteln in die Zinklamellendispersion kann hier ein geforderter Reibwert eingestellt werden. Nicht elektrolytisch aufgebrachte Zinklamellenüberzüge sind genormt in der DIN EN ISO 10683, hauptsächlich aber bekannt unter diversen Produktnamen wie z.B. Geomet oder Delta-Protekt. Das Verfahren ist nicht geeignet für Gewindeteile $\leq M6$ und für Verbindungselemente mit kleinen Innenantrieben oder feinen Konturen.



9

GEOMET

- Geomet 321 ohne Schmiermittel ohne Angabe ($\mu \sim 0,25$)

- Geomet 500 (siehe auch Seite 566-567) mit Schmiermittel PTFE $\mu = 0,12 - 0,18$

Schichtdicke:

- Grad A: Schichtgewicht > 24 g/m², durchschnittliche Schichtdicke 5 bis 8 μ m
- Grad B: Schichtgewicht > 36 g/m², durchschnittliche Schichtdicke 8 bis 10 μ m

Beständigkeit:

- Grade A: > 600 h ohne Rotrost
- Grade B: > 1000 h ohne Rotrost
Kein Weißrost vor 250 h

Delta Protekt

Delta Protekt KL 100 ohne Schmiermittel ($\mu \sim 0,25$)

Schichtdicke
4 bis 15 μ m

Beständigkeit
8 μ m: > 600 h ohne Rotrost
Delta Protekt KL100 + Delta Protekt VH301
10 μ m + 3 μ m : > 960 h ohne Rotrost

Reibungszahlenanforderungen
DELTA-PROTEKT® VH 300
DELTA-PROTEKT® VH 301 GZ \Rightarrow gem. VDA
DELTA-PROTEKT® VH 302 GZ \Rightarrow gem. Ford, Volvo
DELTA-PROTEKT® VH 315 GZ \Rightarrow gem. Renault

Plattieren

Ein zweites Verfahren mit den gleichen Eigenschaften ist unter dem Namen Mechanical Plating bekannt. Hier werden die Verbindungselemente ab der Festigkeitsklasse 10.9 und Federelemente mit Wasser, Chemikalien, Metallpulver und verschiedenen großen Glaskugeln bei Raumtemperatur gerollt. Dabei wird das Überzugmetall Zink mechanisch aufgehämmert. Beim Plattieren und den Zinklamellenüberzügen kann die Schichtdicke zwischen 6 und 20 µm variiert werden.

Passivieren / Dickschichtpassivieren

Im Zusammenhang mit Cr(VI)-freien galvanischen Zinküberzügen wird der Begriff Passivierung anstatt Chromatierung benutzt.

Die Passivierungsschicht ist Chrom(III)-haltig und verhindert über einen gewissen Zeitraum die Zinkkorrosion (Weißrost).

Passivieren wird als Nachbehandlung von galvanisch verzinkten oder cadmierten Teilen verwendet. Es handelt sich um ein chemisches Tauchverfahren im stromlosen, chromsäurehaltigen Bad.

Die Überzugmetalle werden passiver gegen Korrosion (Passivieren)

Die Temperaturbeständigkeit der Chromatierung beträgt max. ca. 60°C.

Zusätzlich besteht die Möglichkeit der nachträglichen Versiegelung durch Zusatz organischer Substanzen zur Verbesserung der Korrosionsbeständigkeit und Abriebfestigkeit siehe hierzu DIN 50961.

Chemisch Vernickeln

Stromlose chemische Beschichtung aus wässriger Nickelsalzlösung zur Erhöhung der Korrosionsbeständigkeit und Verschleißfestigkeit unter Einhaltung gleichmäßiger Schichtdicken, z.B. DURNI-COAT.

Feuerverzinken

Feuerverzinken erfolgt durch Tauchen in schmelzflüssigem Zink bei Temperaturen von ca. 480°C (= thermische/Niedrigtemperatur Feuerverzinkung) oder bei ca. 520°C (= Hochtemperatur-Feuerverzinkung). Dabei werden Schichtdicken bis etwa 100µm aufgetragen, in einem Schleuderverfahren gleich nach dem Tauchen wird überschüssiges Zink entfernt.

Der Korrosionsschutz ist aufgrund der erheblichen größeren Schichtdicken im Fertigzustand (min. 40µm nach DIN EN ISO 10684) wesentlich länger anhaltend als bei Teilen mit galvanischen Zinküberzügen.

In DIN EN ISO 10684 (früher DIN 267-10) wurde der Hinweis aufgenommen, dass Schrauben ab Festigkeitsklasse 10.9 und ab M 27 Durchmesser nicht hochtemperaturverzinkt werden sollen. Hiermit fließen die Erkenntnisse aus der Studie der TU Darmstadt über „Dehnungsinduzierte Spannungsrissskorrosion in der Flüssigzinkphase bei der Hochtemperaturverzinkung...“ in die Normung ein.

Zinküberzüge durch Feuerverzinkung sind hellgrau bis mattgrau, das Aussehen ist werkstoffbedingt und kein Qualitätsmerkmal des Korrosionsschutzes. Eine Nachbehandlung wie Passivieren oder Chromatieren ist bei der Feuerverzinkung nicht üblich, eine dadurch z. B. bei Transport oder Lagerung auftretende „Weißrostbildung“ ist zulässig.

Gemäß DIN EN ISO 10684 beträgt die örtliche Mindestschichtdicke einheitlich für alle Verbindungselemente min 40 µm, die mittlere Schichtdicke des Loses mindestens 50 µm. Als Messstelle ist die Kopffläche oder die Kuppe am Gewindeende bei Bolzen bzw. die Mitte der Schlüsselfläche bei Muttern zu verwenden

Aus verfahrenstechnischen Gründen können die Schichtdicken bei feuerverzinkten Teilen je nach Art der Teile an verschiedenen Stellen deutlich größer als 40 µm sein (z.B. an Schaft oder Kopf bis zu 100µm).





1

Die großen Schichtdicken erfordern für feuerverzinkte Gewindeteile besondere Abmaße in den Gewindetoleranzen, dadurch ist eine Feuerverzinkung erst ab M8 (nach DIN 267-10 ab M6) durchführbar und ab M10 sinnvoll.

Ein Nachschneiden des Bolzensgewindes nach dem Feuerverzinken ist nicht zulässig!



2

Für feuerverzinkte HV-Garnituren nach DIN EN 14399 ff gilt zwingend Variante 2.

DIN EN ISO 10684 lässt zwei Möglichkeiten zur Erreichung der Schraubpassung nach dem Feuerverzinken zu:

Mutterngewinde werden nicht feuerverzinkt, sondern nachträglich in den feuerverzinkten Rohling eingeschnitten. Die durch die größeren Schichtdicken der Feuerverzinkung erhöhte „Fernschutzwirkung“ (kathodischer Schutz) des Zinks schützt das nicht verzinkte Mutterngewinde bei der Verschraubung mit dem feuerverzinkten Bolzen.



3

1. Gewindeuntermaß ins Bolzensgewinde (Toleranz 6az vor Aufbringen des Überzuges – Kennzeichen U) oder



4

2. Gewindeaufmaß ins Mutterngewinde (Toleranz 6AZ oder 6AX – Kennzeichen Z oder X)

Bei der Montage feuerverzinkter Schrauben und Muttern – insbesondere bei zusätzlicher Schmierung des Gewindes – ist mit veränderten Reibewerten und Anziehdrehmomenten zu rechnen, die durch Versuche zu ermitteln sind.



5

Die entsprechenden Bestellbezeichnungen dazu lauten:

1. ISO 4014 – M12 x 80 – 8.8U – tZn



6

2. ISO 4032 – M12 – 8Z – tZn

Korrosionsbeständigkeit



7



8



9

	Trockener Raum	Landluft	Stadtluft	Industrieluft	Meeresluft	Süßwasser	Salzwasser	Säuren / Laugen	Teile bis M6	Teile über M6
eingelöt	x	x							x	x
verzinkt blau chromatiert	x	x	x						x	x
verzinkt gelb chromatiert	x	x	x	x					x	x
Zinklamellen	x	x	x	x						x
feuerverzinkt	x	x	x	x						x
austenit. CrNi-Stahl A2	x	x	x	x	x	x		x	x	x
austenit. CrNi-Stahl A4	x	x	x	x	x	x	x	x	x	x

Die vorangegangene Tabelle vermittelt einen groben Überblick, wo welche Verfahren sinnvoll eingesetzt werden. Die Beständigkeit gegen Korrosion der verschiedenen Schutzüberzüge in allgemein gültige Regeln zu fassen ist relativ schwierig, da gerade bei Verbindungselementen sehr unterschiedliche Betriebsbedingungen auftreten können. Dazu kommen die Zusammensetzung, Temperatur und der Reinheitsgrad des Angriffsmediums sowie die Einbauverhältnisse der zusammengefügteten Teile, aber auch die Werkstoffpaarungen.

Auch die verschiedenen Korrosions-Prüfverfahren, wie

- Kesternich-Test
(Prüfung in feuchter SO₂ - Atmosphäre)
- Schwitzwasserprüfung
- Salzsprühtest

sind keine Garantie für eine korrosionssichere Verbindung unter Betriebsbedingungen. Für eine genauere Einschätzung der Korrosionsbeständigkeit kann die nachfolgende Tabelle herangezogen werden.

DIN EN ISO 14713-1 Zinküberzüge – Leitfäden und Empfehlungen zum Schutz von Eisen- und Stahlkonstruktionen vor Korrosion

Die Norm gilt verfahrensübergreifend für alle metallischen Überzüge aus Zink.

Korrosivitäts-Kategorie	Korrosions-belastung	Durchschnittlicher Zink-Abtrag pro Jahr	Beispiele
C 1	sehr niedrig	<0,1 µm/Jahr	Innen: Beheizte Räume, z.B. Büros, Schulen
C 2	gering	0,1 bis 0,7 µm/Jahr	Innen: Nicht beheizte Räume, z.B. Lager-räume, Sporthallen Außen: ländliche Bereiche
C 3	mittel	0,7 bis 2,0 µm/Jahr	Innen: Lebensmittelverarbeitung, Brau-ereien, Wäschereien, Molkereien, Lei-tungswasserbetriebene Schwimmbäder Außen: städtische Bereiche, Küstenbe-reiche
C 4	hoch	2,0 bis 4,0 µm/Jahr	Innen: Schwimmbäder, Industrieanlagen Außen: Stark verunreinigte städtische Bereiche, industrielle Bereiche, Küsten-bereiche (ohne Versprühen von Salz-wasser), starke Tausalzbelastung
C 5	sehr hoch	4,0 bis 8,0 µm/Jahr	Innen: z.B. Bergwerke, industriell ge-nutzte Kavernen Außen: industrielle Bereiche, Küstenbe-reiche (mit Versprühen von Salzwasser), Schutzhütten an der Küste
C X	extrem	8,0 bis 25 µm/Jahr	Extrem hochkorrosive Atmosphäre, beispielsweise Industrieanlagen in subtropischem und tropischem Klima





1

GEOMET® 500 ist ein nicht elektrolytisch aufgebracht, aluminiumgrauer, dünn-schichtiger Überzug mit integriertem Schmiermittel für den Korrosionsschutz von Teilen aus Stahl, Gusseisen oder sonstigen eisenhaltigen Metallen.



2

GEOMET® 500 besteht aus Zink- und Aluminiumlamellen in einer anorganischen Matrix, mit einem Anteil PTFE. Dieser Überzug wurde von der Firma DACRAL S.A. entwickelt, dem Hersteller von DACROMET® 500, und stellt dabei die chromfreie Alternative dar.



3

Bei der Anwendung von **GEOMET® 500** entsteht keine Wasserstoffversprödung. Die Auftragung erfolgt durch Kalttauchen in eine wässrige Lösung oder durch Spritzen.



4

Korrosionsschutzmechanismus:



5

	Grad	Schichtgewicht	Schichtdicke	Salzsprühtest (ISO 9227)
GEOMET® 500	A	> 24 g/m ²	5-8 µm ^(a)	> 600 Stunden ohne Rotrost > 200 Stunden ohne Weißrost
GEOMET® 500	B	> 36 g/m ²	8-10 µm ^(a)	> 1000 Stunden ohne Rotrost > 200 Stunden ohne Weißrost



6



7

(a) Die Schichtdicke entspricht einem Mittelwert (siehe EN ISO 10 683 oder EN 13 858). Einzelne Messpunkte, insbesondere bei Schüttgut, sind nicht aussagefähig.



8

Reibwerte:

Der Überzug enthält den Schmierstoff PTFE in der gesamten Schichtdicke. Ein kontrollierter Reibwert wird durch dieses Produkt erreicht.



9

GEOMET® 500 : $0,12 \leq \mu_{\text{Mittelwert}} \leq 0,18$

(DIN 964 und Renault 01.50.005/-C)

Eigenschaften:

1. Keine Wasserstoffversprödung: Bei adäquater Oberflächenvorbereitung entsteht durch die nicht-elektrolytische Auftragung keine Wasserstoffversprödung. GEOMET® 500 ist also besonders gut für den Schutz von Sicherheitsteilen geeignet.

GEOMET® 500 ist ein kathodisches Schutzsystem. Der Korrosionswiderstand ist abhängig von der Schichtdicke und ergibt sich aus der Kombination verschiedener Mechanismen:

- Barriere-Effekt durch die Lamellenstruktur des Films,
- kontrollierter, kathodischer Schutz des Zinks im Verhältnis zum eisenhaltigen Substrat,
- Verlangsamung des natürlichen Zink- und Aluminiumverbrauchs durch die Passivierung der gesamten Schichtdicke.

2. Beständigkeit gegen Automobilbetriebsmittel gemäß VDA 621-412: Norm-Kraftstoffe, Diesel, Motorenöl, organische Lösemittel, Kühlflüssigkeit, Bremsflüssigkeiten. Der Widerstand von GEOMET® 500 ist zufriedenstellend. Auch nach einem Eintauchen in Bremsflüssigkeit während 24 Std. bei 20 °C wird der Überzug nicht beeinträchtigt.

3. Duktilität: Ausreichende Duktilität für die elastische Verformung von Stählen, bei Federn, Klipsen, usw.

4. Elektrische Leitfähigkeit : GEOMET® 500 ist begrenzt leitfähig. Die Anwendung von Kathaphorese-Lacke ist möglich.

5. Hitzebeständigkeit: GEOMET® 500 behält seine physischen Eigenschaften bis zu 300 °C, die die erforderliche Temperatur für die Bildung des Überzugs ist. Für Anwendungen über 300 °C sind anwendungsspezifische Tests erforderlich. Der Korrosionswiderstand im Salzsprühnebeltest wird bei einer Wärmelagerung von 100 Stunden bei 180 °C nicht beeinträchtigt.

6. Überlackierbarkeit: GEOMET® 500 kann überlackiert werden. Aufgrund der Lamellenstruktur des Überzugs ist der Klebebandtest mit Ritz nicht aussagefähig.

7. Eindringungsvermögen: Das Kalteintauchverfahren erlaubt die Oberfläche der Teile ganz zu benetzen, deswegen können zum Beispiel die Innenseiten von Rohren oder Hohlräume beschichtet werden.

Anwendungsbereiche:

GEOMET® 500 kann in allen Industriebereichen und für jegliche Art metallischer Teile eingesetzt werden. Es ist besonders gut geeignet für Befestigungselemente. Für die Anwendung in der Automobilindustrie müssen OEM-Normen erfüllt werden. In Industriezweigen, in denen eine spezifische Norm nicht existiert, kann die DIN EN ISO 10 683 und EN 13 858 eingesetzt werden. Diese Norm schreibt Anforderungen an Zinklamellenüberzüge vor. Mehr Information sind über www.dacral.com zu finden.

Umwelt und Entsorgung:

Als wässrige Dispersion werden mit GEOMET® 500 die gesetzlichen Vorschriften für Gasemissionen einfach erfüllt.

Der GEOMET® 500 Überzug enthält keine Schwermetalle. Es entspricht den Vorschriften der europäischen Gesetzgebung in Bezug auf Entsorgung, insbesondere die 2000/53/EG und 2002/95/EG.

Verfahrenstechnik:

GEOMET® 500 wird auf den bereits vorhandenen DACROMETISIERUNGS-Anlagen eingesetzt. Das Beschichtungsverfahren ist wie folgt: Auftragung des feuchten GEOMET®-500-Films durch Kalteintauchen oder Spritzen, Einbrennung bei einer Temperatur von 300 °C. DACRAL S.A. empfiehlt mehrere Anwendungstechniken:

- Tauch-/Schleuderverfahren für Trommelware: Nach der Reinigung werden die Kleinteile in das GEOMET®-Bad getaucht, überflüssiges Produkt wird abgeschleudert. Die feuchten Teile werden zunächst im Ofen getrocknet und dann auf die Temperatur von 300 °C erhitzt, um den Überzug zu bilden.
- Spritzverfahren für Schüttgut: Nach der Reinigung werden die Kleinteile in eine spezielle Spritzanlage eingeführt. Die Technik ist besonders gut für Muttern und kleine Innengriffsschrauben geeignet. Es bilden sich keine Überschichtdicken.
- Tauch-/Abtropf-/Schleuderverfahren für Gestellware: Die Teile werden auf Gestelle gehängt und im gleichen Verfahren wie Trommelware behandelt.
- Spritzen mit Pneumatik-, Elektrostatik-Spritzpistole oder Schnelldrehglocke: Für Teile, für die nur außen ein Korrosionsschutz benötigt wird.



® Eingetragenes Warenzeichen der Metal Coatings International Inc.



1

Um die Dauerhaltbarkeit einer Schraubenverbindung zu gewährleisten, muss die Vorspannkraft möglichst genau bestimmt werden. Die Vorspannkraft von Schraubenverbindung wird durch folgende Faktoren beeinflusst.



2

- die Reibungsverhältnisse in den sich relativ zueinander bewegenden Kontaktflächen (Gewinde und Auflage)



3

- die geometrische Form der Verbindung (Schraube, Mutter, verspannte Teile)



4

- die Festigkeit der Verbindung
- das Anziehverfahren
- das Anziehgerät



5

Anziehdrehmomente

In der nachfolgenden Tabelle sind Anziehdrehmomente für Schraubverbindungen aus vergütetem Stahl aufgeführt. Die berechneten Drehmomente sind jedoch nicht exakt in Vorspannkraft umzusetzen, da insbesondere die tatsächliche Reibung von den angenommenen Werten abweichen kann. Um solche Streuungen möglichst einzuengen, wird in drei Reibwerte unterschieden:



6



7

Reibwert $\mu = 0,14$ bei Montage von handelsüblichen Schrauben und Muttern ohne Schmier-
ung



8

Reibwert $\mu=0,125$ für geölte oder gefettete Kontaktflächen



9

Reibwert $\mu=0,10$ für MoS₂ oder ähnlichen Stoffen behaftete Kontaktflächen

(Kontaktflächen = Gewindeflanken und Kopf- bzw. Mutterauflage)

Fehler beim Abschätzen der Reibungszahlen, Streuungen der Reibungszahlen, unterschiedliche Anziehverfahren sowie Geräte-, Bedienungs- und Ablesefehler führen zu einer mehr oder weniger großen Streuung der Montagevorspannkraft.

Das Anziehen nach Gefühl sollte generell nicht angewendet werden! Erfahrungswerte haben gezeigt das Schrauben bis M12 meistens über die Streckgrenze angezogen sind, Schrauben über M14 meist zu niedrig angezogen.

Zur exakten Bestimmung der Vorspannkraft bzw. des Anziehmoments ist die Kenntnis über den vorhandenen Reibungskoeffizienten Voraussetzung. Die Angaben enthalten lediglich unverbindliche Richtwerte. Eine ausführliche Schraubenberechnung kann durch diese Werte nicht ersetzt werden. Das gilt insbesondere für Teile, die sicherheitsrelevant sind, behördlichen Vorschriften unterliegen oder Dichtungsaufgaben erfüllen. Es kann keine Gewähr für diese Werte abgegeben werden.

Die Reibwerte bei Verbindungselementen aus nicht rostendem Stahl sind wesentlich größer als bei Stahlschrauben. Desweiteren hat der Reibwert eine wesentlich größere Streuung (über 100% möglich!). Bei Bestimmung des richtigen Drehmomentes sind Versuche unter Realbedingungen empfohlen.

Durch den Einsatz von Schmiermittel lässt sich die Reibungszahl verringern, die Problematik des großen Streubereichs bleibt jedoch erhalten.

Richtwerte für die Ermittlung der Reibungszahl entnehmen sie bitte aus der Nachfolgenden Tabelle.

Schrauben aus	Mutter aus	Schmiermittel		Nachgiebigkeit der Verbindung	Reibungszahl	
		im Gewinde	unter Kopf		im Gewinde μ_G	unter Kopf μ_K
A2	A2	ohne	ohne	sehr groß	0,26 bis 0,50	0,35 bis 0,50
		Spezialschmiermittel (Molykote)			0,12 bis 0,23	0,08 bis 0,12
		Korrosionsschutzfett			0,26 bis 0,45	0,25 bis 0,35
		ohne	ohne	klein	0,23 bis 0,35	0,12 bis 0,16
		Spezialschmiermittel (Molykote)			0,10 bis 0,16	0,08 bis 0,12

Hinweis:

Verbindungselemente aus austenitischen Werkstoffen neigen bei der Montage zum kaltverschweißen „fressen“. Folgende Maßnahmen wirken dem entgegen:

- glatte, saubere Gewinde
- (gerollte Gewinde)
- Schmiermittel
- niedrige Umdrehungszahl des Schraubers, zügiges Anziehen ohne Unterbrechung.



Anziehdrehmomente¹⁾ - Stahl -
bei Ausnutzung der Streckgrenze R_{p0,2} von 90%



Gewinde	Reibwert $\mu_{ges}^{2)}$	Festigkeitsklasse [Ncm]							
		3.6	4.6	4.8	5.6	5.8	8.8	10.9	12.9
M 1,6	0,100	4,5	5	6,5	8,5	15	21	25	
	0,125	5	5,5	7,5	9,5	17	24	29	
	0,140	6,5	6	8	10	18	25	30	
M 1,8	0,100	5,5	6	8	10	18,5	26	32	
	0,125	6,5	7	9,5	11,5	21	30	36	
	0,140	7	7,5	10	12,5	23	32	38	
M 2	0,100	9,5	10,5	13,5	17	31	44	52	
	0,125	11,5	12	15,5	19	35	50	60	
	0,140	12	13	16,5	21,5	38	63	64	
M 2,5	0,100	20	21	28	36	63	89	107	
	0,125	23	25	32	39	73	102	123	
	0,140	25	27	34	43	78	109	131	
M 3	0,100	35	38	49	63	111	157	188	
	0,125	42	44	56	72	128	180	215	
	0,140	44	47	60	78	137	192	230	
M 3,5	0,100	54	59	75	96	171	240	290	
	0,125	63	68	86	110	196	275	330	
	0,140	67	73	92	119	210	295	395	
M 4	0,100	82	88	112	144	255	360	430	
	0,125	94	102	128	166	290	410	495	
	0,140	100	108	137	177	310	440	525	
M 5	0,100	160	170	220	280	500	705	845	
	0,125	180	200	250	320	575	810	970	
	0,140	190	210	270	340	615	865	1040	
		Festigkeitsklasse [Nm]							
M 6	0,100	2,8	3	3,8	4,8	8,6	12	14,5	
	0,125	3,2	3,4	4,3	5,6	9,9	14	16,5	
	0,140	3,5	3,7	4,6	6	10,5	15	18	
M 8	0,100	6,8	7,2	9,1	11,7	21	29	35	
	0,125	7,9	8,3	10,5	13,6	24	34	40	
	0,140	8,4	8,9	11	14,5	26	36	43	
M 10	0,100	13,5	14,4	18	23,4	42	58	70	
	0,125	15,5	16,6	21	27	48	67	81	
	0,140	17	18	22	29	51	72	87	
M 12	0,100	24	25	33	41	72	101	121	
	0,125	27	29	36	47	83	117	140	
	0,140	29	31	39	50	89	125	150	

Montage

Anziehdrehmomente¹⁾ - Stahl -
bei Ausnutzung der Streckgrenze $R_{p0,2}$ von 90%

Gewinde	Reibwert $\mu_{ges}^{2)}$	Festigkeitsklasse [Nm]							
		3.6	4.6	4.8	5.6	5.8	8.8	10.9	12.9
M 14	0,100	37	40	50	47	114	160	193	
	0,125	43	46	58	74	132	185	220	
	0,140	46	50	62	81	141	198	240	
M 16	0,100	57	60	76	98	174	245	295	
	0,125	66	70	88	115	200	285	340	
	0,140	71	76	95	124	215	305	365	
M 18	0,100	79	83	105	135	240	340	405	
	0,125	91	95	121	155	275	390	470	
	0,140	97	105	130	171	295	420	500	
M 20	0,100	111	120	148	195	340	475	570	
	0,125	128	135	170	219	390	550	660	
	0,140	138	146	184	238	420	590	710	
M 22	0,100	149	160	199	260	455	640	765	
	0,125	173	183	230	298	530	745	890	
	0,140	186	198	250	322	570	800	960	
M 24	0,100	191	203	255	330	580	820	980	
	0,125	220	235	295	382	675	950	1140	
	0,140	235	251	315	408	725	1020	1220	
M 27	0,100	280	300	375	488	855	1210	1450	
	0,125	325	348	435	566	995	1400	1680	
	0,140	350	376	470	610	1070	1510	1810	
M 30	0,100	380	405	510	658	1160	1640	1970	
	0,125	445	470	590	763	1350	1900	2280	
	0,140	475	504	635	818	1450	2050	2450	
M 33	0,100	515	552	590	898	1570	2210	2650	
	0,125	600	645	800	1045	1830	2580	3090	
	0,140	645	685	865	1110	1970	2770	3330	
M 36	0,100	665	705	885	1145	2030	2850	3420	
	0,125	775	825	1030	1340	2360	3310	3980	
	0,140	830	885	1111	1435	2530	3560	4280	
M 39	0,100	860	920	1150	1495	2620	3680	4420	
	0,125	1000	1075	1340	1750	3050	4290	5150	
	0,140	1080	1155	1440	1880	3290	4620	5550	



¹⁾ gültig für DIN 931/933 und 912 in Verbindung mit der dazugehörigen Mutter nach DIN 934. Für DIN 7991, DIN 6912, DIN 7984; ISO 7380, sind die Werte auf 80% zu reduzieren.

²⁾ für Schrauben und Muttern in handelsüblicher Ausführung kann ein Reibwert μ_{ges} von 0,14 angenommen werden.

Anziehdrehmomente¹⁾ - nicht rostender Stahl -
bei Ausnutzung der Streckgrenze $R_{p0,2}$ von 90%



	Reibwert μ_{ges}	Vorspannkraft F_M [kN]			Anziehdrehmoment M_A [Nm]		
		Festigkeitsklasse			Festigkeitsklasse		
		50	70	80	50	70	80
M1,6	0,1	0,4	0,55	0,6	0,1	0,1	0,2
	0,2	0,3	0,35	0,4	0,1	0,2	0,35
	0,3	0,2	0,3	0,35	0,2	0,25	0,45
M2	0,1	0,5	0,6	0,8	0,15	0,2	0,3
	0,2	0,4	0,5	0,6	0,25	0,3	0,4
	0,3	0,25	0,35	0,4	0,4	0,4	0,55
M2,5	0,1	0,65	0,9	1	0,25	0,45	0,6
	0,2	0,4	0,5	0,85	0,25	0,6	0,65
	0,3	0,3	0,3	0,6	0,6	0,75	0,8
M3	0,1	0,9	1	1,2	0,7	1	1,3
	0,2	0,6	0,65	0,95	1	1,1	1,6
	0,3	0,4	0,45	0,7	1,25	1,35	1,85
M4	0,1	1,08	2,94	3,96	0,8	1,7	2,3
	0,2	1,12	2,4	3,2	1,3	2,6	3,5
	0,3	0,9	1,94	2,59	1,5	3	4,1
M5	0,1	2,26	4,85	6,47	1,6	3,4	4,6
	0,2	1,86	3,93	5,24	2,4	5,1	6,9
	0,3	1,49	3,19	4,25	2,8	6,1	8
M6	0,1	3,2	6,85	9,13	2,8	5,9	8
	0,2	2,59	5,54	7,39	4,1	8,8	11,8
	0,3	2,08	4,49	5,98	4,8	10,4	13,9
M8	0,1	5,86	12,6	16,7	6,8	14,5	19,3
	0,2	4,75	10,2	13,6	10,1	21,4	28,7
	0,3	3,85	8,85	11	11,9	25,5	33,9
M10	0,1	9,32	20	26,6	13,7	30	39,4
	0,2	7,58	16,2	21,7	20,3	44	58
	0,3	6,14	13,1	17,5	24	51	69
M12	0,1	13,6	29,1	38,8	23,3	50	67
	0,2	11,1	23,7	31,6	34	74	100
	0,3	9	19,2	25,6	41	88	117
M14	0,1	18,7	40	53,3	37,1	79	106
	0,2	15,2	32,6	43,4	56	119	159
	0,3	12,3	26,4	35,2	66	141	188

Montage

Anziehdrehmomente¹⁾ - nicht rostender Stahl -
bei Ausnutzung der Streckgrenze $R_{p0,2}$ von 90%

	Reibwert μ_{ges}	Vorspannkraft F_M [kN]			Anziehdrehmoment M_A [Nm]		
		Festigkeitsklasse			Festigkeitsklasse		
		50	70	80	50	70	80
M16	0,1	25,7	55	73,3	56	121	161
	0,2	20,9	44,9	59,8	86	183	245
	0,3	17	36,4	48,6	102	218	291
M18	0,1	32,2	69	91	81	174	232
	0,2	26,2	56,2	74,9	122	260	346
	0,3	21,1	45,5	60,7	144	308	411
M20	0,1	41,3	88,6	118,1	114	224	325
	0,2	33,8	72,4	96,5	173	370	494
	0,3	27,4	58,7	78,3	205	439	586
M22	0,1	50	107	143	148		
	0,2	41	88	118	227		
	0,3	34	72	96	272		
M24	0,1	58			187		
	0,2	47			284		
	0,3	39			338		
M27	0,1	75			275		
	0,2	61			421		
	0,3	50			503		
M30	0,1	91			374		
	0,2	75			571		
	0,3	61			680		
M33	0,1	114			506		
	0,2	94			779		
	0,3	76			929		
M36	0,1	135			651		
	0,2	110			998		
	0,3	89			1189		
M39	0,1	162			842		
	0,2	133			1300		
	0,3	108			1553		



¹⁾ gültig für DIN 931/933 und 912 in Verbindung mit der dazugehörenden Mutter nach DIN 934. Für DIN 7991, DIN 6912, DIN 7984; ISO 7380, sind die Werte auf 80% zu reduzieren.



Anziehdrehmomente für HV-Garnituren nach DIN EN 14399, 10.9

Anziehdrehmoment [Nm]		M12	M16	M20	M22	M24	M27	M30	M36
Drehmoment-Verfahren (K1) ¹⁾	Vorspannkraft $F_V^{2)} = 0,7 * f_{yb} * A_S$	50	100	160	190	220	290	350	510
	Anziehmoment M_A für F_V	100	250	450	650	800	1250	1650	2800
Kombiniertes-Verfahren (K1) ³⁾	Vorspannkraft $F_{P,C} = 0,7 * f_{ub} * A_S$	60	110	175	210	240	320	390	560
	Voranziehmoment $M_{VA}^{4)}$ für $F_{P,C}$	75	190	340	490	600	940	1240	2100

1) nach DIN EN 1993-1-8

2) F_V entspricht $F_{P,C}^*$ nach EN 1993-1-8

3) nach DIN EN 1090-2

4) gemäß Herstellerempfehlung Peiner Umformtechnik

Die angegebenen Anziehdrehmomente für DIN EN 14399 sind gültig für die feuerverzinkte Ausführung sowie die „schwarze“-Ausführung. Es wird also nicht mehr hinsichtlich der Oberflächenausführung unterschieden.

Weiterdrehwinkel bzw.- umdrehungsmaß für Klemmlänge gesamt

60°	90°	120°
1/6	1/4	1/3
$\sum t < 2d$	$2d \leq \sum t < 6d$	$6d \leq \sum t \leq 10d$

Anziehdrehmomente von SB-Garnituren - ISO 4014, 4017 und 4032

Die Angaben sind als Richtwerte zu verstehen und gelten für die Festigkeitsklasse 8.8, feuerverzinkt / leicht geölt

Anziehdrehmoment [Nm]	M12	M16	M20	M22	M24	M27	M30	M36
8.8 - SB ¹⁾ $M_{A,SOLL} = 0,15 \times d \times F_{p,C}$	70	170	300	450	600	900	1200	2100

1) nach DIN EN 1993-1-8 (K1)

Anziehdrehmoment von SB-Garnituren - DIN 7990

Die Angaben sind als Richtwerte zu verstehen und gelten für die Festigkeitsklasse, feuerverzinkt, Vorspannung rd. $0,3 R_{m A_s}$

Festigkeits- klasse	Anziehdrehmoment [Nm]	
	4.6	5.6
M12	25	30
M16	70	85
M20	120	150
M22	175	220
M24	215	265
M27	330	415
M30	440	550

Anziehdrehmomente von SB-Garnituren, - „Handfest“-Angezogen

Die Angaben sind als Richtwerte zu verstehen und gelten unabhängig der Festigkeitsklasse.

	Anziehdrehmoment [Nm]
M12	15
M16	35
M20	60
M22	90
M24	110
M27	165
M30	220
M36	350





Anziehdrehmoment für Schrauben aus Stahl mit Feingewinde

Unverbindliche Richtwerte für Schrauben DIN 912, 960, 961 in Verbindung mit Muttern nach DIN 934 bei einem Gesamtreibwert von $\mu = 0,14$. Ausnutzung der Streckgrenze von 90%.

Nennmaß	Anziehdrehmomente [Nm] für Festigkeitsklasse		
	8.8	10.9	12.9
M8x1	29,2	42,8	50,1
M10x1,25	57	83	98
M12x1,25	101	149	174
M12x1,5	97	143	167
M14x1,5	159	234	274
M16x1,5	244	359	420
M18x1,5	368	523	613
M20x1,5	511	728	852
M22x1,5	692	985	1153
M24x2	865	1232	1442
M27x2	1262	1797	2103
M30x2	1756	2502	2927

Messing

Messing ist eine Legierung aus Kupfer und Zink. Je nach Mischungsverhältnis variiert die

Farbe von goldorange (bei hohem Kupferanteil) bis hellgelb. Spanlosgefertigte (gepresste) Verbindungselemente sind in der Regel aus CU2 (Ms63), gedrehte Teile aus CU3 (Ms58).

Anziehdrehmomente für Schrauben aus Messing¹⁾

Nennmaß	M2	M2,5	M3	M4	M5	M6	M8	M10	M12	M14	M16
Anziehdrehmoment [Nm]	0,14	0,29	0,5	1,2	2,2	3,9	9	17	29	45	70

¹⁾ unverbindliche Richtwerte für DIN 931/933 und 912 in Verbindung mit der dazugehörigen Mutter nach DIN 934 bei einem Gesamtreibwert von $\mu = 0,14$.

Polyamid PA 6.6

Polyamid 6.6 (PA 6.6) ist ein teilkristallines Polyamid mit guten mechanischen Eigenschaften. Der Werkstoff zeichnet sich durch eine relativ

hohe Wärmeformbeständigkeit und eine geringe Wasseraufnahme aus. Daher hat sich das Material zu einem Standardkunststoff im Maschinen-, Fahrzeug- und Apparatebau entwickelt.

Anziehdrehmomente für Schrauben und Muttern aus Polyamid PA6.6 bei 20°C [Nm]

Nennmaß	M3	M4	M5	M6	M8	M10	M12	M14	M16
Schrauben	0,1	0,2	0,5	1,0	2,0	3,0	4,0	6,0	7,5
Muttern	0,1	0,3	0,6	1,5	3,0	4,0	5,0	7,5	9,0

Alle Angaben sind als Richtwerte nach Lagerung in Normalklima zu verstehen. Die Vorspannkraft kann bedingt durch Relaxationsvorgänge nachlassen.





Ø 2,2
Werkstoff-Festigkeit in N/mm²

s	100	300	500
0,8	1,7	1,7	1,8
0,9	1,7	1,7	1,7
1,0	1,7	1,7	1,8
1,1	1,7	1,7	1,8
1,2	1,7	1,7	1,8
1,3	1,7	1,7	1,8
1,4	1,7	1,7	1,9
1,5	1,7	1,8	1,9
1,6	1,7	1,8	1,9
1,7	1,7	1,8	1,9
1,8	1,7	1,8	1,9

Ø 2,9
Werkstoff-Festigkeit in N/mm²

s	100	300	500
1,1	2,2	2,2	2,2
1,2	2,2	2,2	2,3
1,3	2,2	2,2	2,3
1,4	2,2	2,2	2,4
1,5	2,2	2,2	2,4
1,6	2,2	2,3	2,4
1,7	2,2	2,3	2,4
1,8	2,2	2,3	2,5
1,9	2,2	2,4	2,5
2,0	2,2	2,4	2,5
2,2	2,2	2,4	2,5

Ø 3,5
Werkstoff-Festigkeit in N/mm²

s	100	300	500
1,3	2,6	2,6	2,8
1,4	2,7	2,7	2,8
1,5	2,7	2,7	2,9
1,6	2,7	2,7	2,9
1,7	2,7	2,7	2,9
1,8	2,7	2,8	2,9
1,9	2,7	2,8	3,0
2,0	2,7	2,9	3,0
2,2	2,7	2,9	3,0
2,5	2,7	3,0	3,1
2,8	2,7	3,0	3,1

Ø 3,9
Werkstoff-Festigkeit in N/mm²

s	100	300	500
1,3	2,9	2,9	3,1
1,4	2,9	2,9	3,1
1,5	3,0	3,0	3,2
1,6	3,0	3,0	3,2
1,7	3,0	3,1	3,3
1,8	3,0	3,1	3,3
1,9	3,0	3,2	3,3
2,0	3,0	3,2	3,3
2,2	3,0	3,2	3,4
2,5	3,0	3,3	3,4
2,8	3,0	3,4	3,4

Ø 4,2
Werkstoff-Festigkeit in N/mm²

s	100	300	500
1,4	3,1	3,1	3,4
1,5	3,2	3,2	3,4
1,6	3,2	3,2	3,4
1,7	3,2	3,2	3,4
1,8	3,2	3,3	3,5
1,9	3,2	3,3	3,5
2,0	3,2	3,4	3,5
2,2	3,2	3,4	3,6
2,5	3,2	3,5	3,6
2,8	3,2	3,6	3,6
3,0	3,2	3,6	3,7
3,5	3,3	3,6	3,7

Ø 4,8
Werkstoff-Festigkeit in N/mm²

s	100	300	500
1,6	3,6	3,6	3,9
1,7	3,6	3,7	4,0
1,8	3,6	3,8	4,0
1,9	3,6	3,8	4,0
2,0	3,6	3,9	4,1
2,2	3,6	3,9	4,1
2,5	3,6	4,0	4,2
2,8	3,6	4,1	4,3
3,0	3,7	4,1	4,2
3,5	3,8	4,2	4,3
4,0	4,0	4,2	4,3

Ø 5,5				Ø 6,3			
Werkstoff-Festigkeit in N/mm ²				Werkstoff-Festigkeit in N/mm ²			
s	100	300	500	s	100	300	500
1,8	4,2	4,3	4,6	1,8	4,9	5,0	5,4
1,9	4,2	4,4	4,7	1,9	4,9	5,1	5,4
2,0	4,2	4,4	4,7	2,0	4,9	5,2	5,5
2,2	4,2	4,5	4,8	2,2	4,9	5,3	5,6
2,5	4,2	4,7	4,8	2,5	4,9	5,4	5,6
2,8	4,2	4,7	4,9	2,8	4,9	5,5	5,7
3,0	4,2	4,8	4,9	3,0	4,9	5,6	5,7
3,5	4,4	4,8	4,9	3,5	5,2	5,7	5,8
4,0	4,6	4,9	5,0	4,0	5,3	5,7	5,8
4,5	4,7	4,9	5,0	4,5	5,5	5,8	5,8
				5,0	5,5	5,8	5,8

Gestanzte Löcher müssen evtl. 0,1 - 0,3 mm größer gewählt werden. Es sollte nur in Stanzrichtung verschraubt werden.
s = Blechdicke

Verarbeitung von Bohrschrauben DIN 7504

Für die Montage von Bohrschrauben nach DIN 7504 sind Akku-, Elektro- oder Druckluftschrauber geeignet. Bei Werkstoffen, die schwierig zu bohren sind, muss die Drehzahl versuchsweise ermittelt und angepasst werden. Rostfreie Bleche z.B. lassen sich kaum durchbohren. Bei einer Unterschreitung der Blechdicke können Deformationen durch den Anpressdruck, oder Überdrehungen entstehen. Die entstehenden Bohrspäne sind zu berücksichtigen (Korrosionsgefahr, Kurzschlüsse), ebenso eine gewisse Verletzungsgefahr durch die immer vorstehende Bohrspitze. Diese spezielle Bohrspitze verhindert ein Abwandern, so dass nicht angekört werden muss.

Der Bohrvorgang benötigt einen bestimmten Anpressdruck (Tabelle). Bei wesentlichem überschreiten dieser Werte können Bohrspitzen partiell durch Ausbrechen oder Verglühen zerstört werden.

D	Axialkraft [N]	Drehzahl [U/min ⁻¹]
2,9	150	2500
3,5	150	2500
3,9	150	2500
4,2	250	2500
4,8	250	2500
5,5	350	1800
6,3	350	1800



1



Grundlagen

Das Lockern oder Lösen einer Schraubverbindung kann durch Setzvorgänge eingeleitet werden.

2



Diese führen zu einer Reduzierung der bei der Montage eingeleiteten Vorspannkraft. Hieraus resultiert ein Spiel in der Verbindung.

3



Durch den entstandenen Bewegungsraum wird die Schraube bei jeder Belastung verformt. Diese Verformung führt schließlich zu einer Materialermüdung bzw. Überlastung der Schraubverbindung.

4



Bei dynamisch querbelasteten Schraubverbindungen besteht die Möglichkeit eines vollständig selbsttätigen Losdrehens. Dies geschieht, wenn die Klemmkraft den Reibschluss in der Verbindung nicht mehr aufrecht erhalten kann.

5



Die folglich auftretenden Querverschiebungen führen zu einer Pendelbewegung der Schraube und somit zu einer Relativbewegung im Gewinde der Mutter. Die Schraubverbindung löst sich.

7



Konstruktive Maßnahmen zur Vermeidung von Vorspannkraftverlust durch Setzvorgänge:

- Vermeidung von weichen Scheiben in hochfesten Schraubverbindungen
- Keine Lackschichten unter Schrauben- und Mutternauflagen
- Einsatz möglichst langer Schrauben
- Einsatz von Dehnschrauben oder Dehnhülsen
- Einsatz von hochfesten Schrauben, d. h. Verminderung der Durchmesser und somit Erhöhung der Elastizität.

8



9



Grundsätzlich ist darauf zu achten, dass die Festigkeit aller an der Verbindung beteiligten Komponenten annähernd gleich ist.

Konstruktive Maßnahmen gegen Vorspannkraftverlust bei dynamischer Querbelastung:

- Einsatz von Schraubenverbindungen mit höherer Festigkeitsklasse und damit Erhöhung der Klemmkräfte, die wiederum Querverschiebungen minimieren
- Erhöhung der elastischen Dehnung durch Einsatz von längeren Schrauben (Richtwert $> 5d$)
- Erhöhung der Reibung im Gewinde (möglichst nicht beim Anziehen)
- Schlupfbegrenzung, z. B. durch Einsatz von Passschrauben

Allgemein gilt bei Schraubverbindungen:

Treten Belastungen auf, die dazu führen, dass die konstruktiven Maßnahmen nicht ausreichen, so sind zusätzliche Sicherungselemente zu verwenden!

Beim Sichern kann in drei verschiedene Arten unterschieden werden:

1. Setzsicherung

Kompensation der Setzbewegung durch Federwirkung, Die Vorspannkraft bleibt erhalten.

Mitverspannte federnde Elemente:

- Tellerfedern DIN 2093
- Spanscheiben DIN 6796
- Sicherungsscheiben Schnorr N0110

Verringerung der Flächenpressung:

- Flanschschrauben DIN 6921
- Flanschmuttern DIN 6923
- Unterlegscheiben ISO 7089

2. Verliersicherung

Diese verhindert lediglich ein Auseinanderfallen der Verbindung z.B. durch Erhöhung der Reibung. Die Vorspannkraft geht bis auf ca. 20% verloren, danach bleibt sie konstant.

Formschlüssige Elemente:

- Kronenmuttern DIN 935
- Schrauben mit Splintloch

Klemmende Elemente:

- Ganzmetallmuttern mit Klemmteil DIN 6927
- Muttern mit Kunststoffeinsatz DIN 6926
- Kunststoffbeschichtung z.B. TufLok-Fleck

3. Losdrehsicherung

Diese Sicherungselemente verhindern die Relativbewegung zwischen den Verbindungselementen z.B. durch Sicherungsrippen oder verkapselte Klebstoffe. Es bleiben 80% der Vorspannkraft erhalten.

Spannende Elemente:

- Rippsschrauben P158 P251
- Rippmuttern P193
- Sperrzahnschrauben P151
- Sperrkantscheiben N0125

Klebende Elemente:

- Mikroverkapselte Klebstoffe z.B. precote 80
- Flüssigklebstoff z.B. Loctite 243

Keil-Sperrverfahren:

- Keilscheiben Nord-Lock N0115

Zurückgezogene Normen

Die folgenden Normen haben nach aktuellem Stand der Technik keine Sicherungswirkung und sind auch nicht als Setzsicherung geeignet:

- Federringe DIN 127, DIN 128 und DIN 6905
- Federscheiben DIN 137 und DIN 6904
- Zahnscheiben DIN 6797
- Fächerscheiben DIN 6798 und DIN 6908
- Sicherungsbleche DIN 93, DIN 432 und DIN 463
- Sicherungsnapfe DIN 526
- Sicherungsmuttern DIN 7967
- Kronenmutter mit Splint DIN 937



Sichern von Schraubverbindungen

Übersicht sichernde Beschichtungen



1

Beim Eindrehen und Vorspannen im Muttergewinde wird durch den Druck zwischen den Gewindeflanken ein Teil der Kapseln zerstört.



2

Der auslaufende Klebstoff verbindet sich mit dem Bindersystem und füllt die Zwischenräume zwischen Mutter und Bolzensgewinde vollständig aus. Die anschließende Aushärtung (3-12 Stunden) verhindert ein Losdrehen auch unter starken Vibrationen.



3



4



5



6



7



8



9

Bei allen Klebeverbindungen gilt auch bei diesen das Beachten der folgenden Grundsätze:

- Saubere Oberflächen ergeben optimale Resultate.
- Temperaturbeständigkeit (max. 150°C).
- Gewindereibwert wird etwas erhöht.
- Aushärtezeit muss abgewartet werden.
- Chemische Beständigkeit muss überprüft werden.

Sicherung	Wirkung	Beschichtung
Polyamid Fleck	Klemmend	rot, blau oder grün
Polyamid rundum	Klemmend, dichtend	rot, blau oder grün
Polyamid temperaturbeständig Fleck	Klemmend temperaturbeständig	braun
Polyamid temperaturbeständig Rundum	Klemmend, dichtend	braun
precote 30	Mittelfest klebend, dichtend, μ Gew. 0,10-0,15	gelb
precote 80	Sehr hochfest klebend, dichtend, μ Gew. 0,25-0,28	rot
precote 85	Hochfest klebend, dichtend, μ Gew. 0,10-0,15	türkis
precote 85-8	Hochfest klebend, dichtend, μ Gew. 0,10-0,15	türkis
Scotch Grip 2353	Hochfest klebend, dichtend, μ Gew. 0,13-0,18	blau
Scotch Grip 2510	Hochfest klebend, dichtend, μ Gew. 0,12-0,15	orange

precote 30/80/83/85•3M 2353/2510 - sichernde Beschichtung für Außen- und Innengewinde

Anwendungsbereich

Entsprechend den Anforderungen der Praxis werden unterschiedliche Standardprodukte angeboten.

precote 30:

für Gewindedichtung und mittelfeste Gewindegewissicherung. Leichte Demontage, keine Nachhärtung.

precote 80:

Universal-Schraubensicherung, hochfest, temperaturbeständig bis 170°C.

precote 83:

besonders schnell härtende Variante von precote 80.

precote 85:

Universal-Schraubensicherung, hochfest mit niedrigem Gewindeeibwert; temperaturbeständig bis 150°C.

3M:

klebende und dichtende Funktion, unempfindlich gegen Öl und Fett, zuverlässige, selbstsichernde Wirkung bei Vibrationskräften quer zur Schraubenachse.

(Rüttelversuche nach DIN 65151)

Produktmerkmale

- Höchste Sicherungswirkung gegen dynamische Beanspruchung und absolut zuverlässige Abdichtung.
- Hohe Temperaturbeständigkeit von -80°C bis +170°C (bei precote 80).
- Schraube und Sicherungselement sind untrennbar miteinander verbunden. Daher kein Verlieren oder Vergessen der Schraubensicherung.
- Ersetzt herkömmliche, z. T. unzuverlässige mechanische Sicherungselemente, wie Sicherungsringe, Kronenmuttern, Unterlegscheiben, Drahtsicherungen, Sicherungsbleche, etc.
- Gute Chemikalienbeständigkeit z. B. gegen Kraftstoffe, Hydraulik-Öle, Kühlflüssigkeiten, usw. Korrosionshemmend.
- Wirtschaftlich durch Großserienbeschichtung und Verwendung der üblichen Montagegeräte.
- Erspart Disposition, Lagerhaltung und Montage zusätzlicher Sicherungsmaterialien.

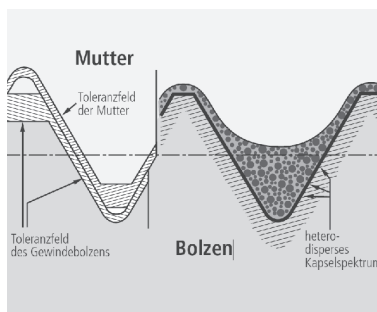

Sichern von Schraubverbindungen

Beschichtung mit Kunststoffkleber (precote, 3M)



1

**precote 30/80/83/85 • 3M 2353/2510 -
klebende Beschichtung entsprechend DIN 267, Teil 27 Werknorm 924. bis 929**



2

Anwendung

Zur Herstellung montagefertiger, selbstsichernder Schrauben und Gewindeteile ab M3.

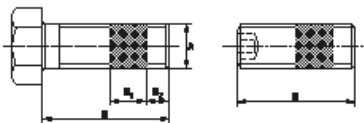

3

Standard-Beschichtung außen

B1 ≈ A, 360° rundum. Etwa 2 bis 3 Gewindegänge bleiben unbeschichtet zum leichteren Einschrauben (B2). Mindestlänge (B): 10 mm

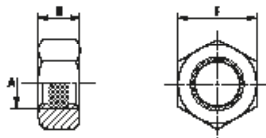

4

Standard-Beschichtung innen

360° rundum. Jeweils ca. erster und letzter Gewindegang bleiben unbeschichtet zum leichteren Einschrauben.



5



6

Artikel-Nr.

Kopfschrauben

**precote
30**

**precote
80/83**

**precote
85**

**3M
2353**

**3M
2510**

926... ..300 926... ..800 926... ..900 928... ..000 928... ..900

Stiftschrauben

927... ..300 927... ..800 927... ..900 929... ..000 929... ..900

Muttern Innengewinde

924... ..300 924... ..800 924... ..900 925... ..000 925... ..900

Beschichtungsfarbe

gelb

rot

türkis

blau

orange

Losbrechmoment:

unter Vorspannung montiert

≤ 0,9 M_A

≥ 0,9 M_A

≥ 0,9 M_A

0,9 M_A

≥ 0,9 M_A

ohne Vorspannung montiert

mind. 8 Nm

mind. 10 Nm

mind. 10 Nm

mind. 10 Nm

mind. 10 Nm

Temperaturbereich

-50°C bis +120°C

-50°C bis 170°C

-50°C bis +150°C

-80°C bis +90°C

-30°C bis +150°C

Gewindereibungszahl μ (Richtwerte)

0,12 bis 0,14

0,25 bis 0,28

0,10 bis 0,15

0,18 bis 0,22

0,20 bis 0,25

Aushärtezeit (Raumtemperatur)

24h

24h

24h

24h

72h

M_A = Anzugsmoment

Alle Werte sind bezogen auf Schrauben M10 schwarz vergütet (Gewindepaarung mittlere Toleranzlage), Beschichtungsbreite ≈ A, 360° rundum.

precote 30/80/83/85•3M 2353/2510 - sichernde Beschichtung für Außen- und Innengewinde

Oberflächenbeschaffenheit

Die Beschichtung kann auf alle metallischen Gewindewerkstoffe aufgebracht werden. **Die Gewinde sollten öl- und fettfrei sein.** Für blanke, phosphatierte Teile sind geeignete Korrosionsschutzmittel zulässig. Bei reibwertreduzierten Oberflächen kann es zu einer Reduzierung des Losbrechdrehmoments (M_{LB}) kommen.

Aushärteverhalten

Die Aushärtung beginnt kurz nach dem Eindrehen des Gewindes. Justier- und Anzugsvorgänge sollten daher binnen 5 Minuten abgeschlossen sein. Eine ausreichende Funktionsfestigkeit ist meist schon nach ca. 30 Minuten erreicht; schnellere Aushärtung mit precote 83. precote 80 härtet auch bei Temperaturen bis -20°C aus, jedoch mit niedrigerer Aushärtegeschwindigkeit.

Lagerbeständigkeit

der beschichteten Gewinde: 4 Jahre bei Raumtemperatur. precote 30 und precote 80 auch bei extrem hoher Luftfeuchtigkeit noch besonders gut lagerfähig.

Wiederverwendbarkeit

Gewinde mit der Beschichtung 3M 2353 und 3M 2510 können bei Einhaltung der Randbedingungen (Gewinde öl- und fettfrei) mehrmals eingesetzt werden. Da jedoch undefinierbare Voraussetzungen entstehen können, wird von nochmaliger Verwendung einmal losgebrochener Gewindeteile abgeraten.

Weitere technische Einzelheiten sind je nach Einsatzfall zu klären.

1



2



3



4



5



6



7



8



9





1

TufLok® „der blaue Fleck“ hat sich weltweit bewährt: in der Automobil-Industrie, im Schwermaschinen-, Armaturen- und Gerätebau, bei Hydraulik-Anlagen, in der Elektro- und Feinmechanik und in der Optik.



2

Der TufLok-Fleck eignet sich auch dort, wo andere Systeme technisch oder wirtschaftlich versagen:



3

- für sehr kleine Schrauben – ab M 0,8
- für Schrauben aus hartem Werkstoff



4

- für Schrauben, die im Querschnitt nicht geschwächt werden
- für Gewindestifte



5

Anwendungsbereich

TufLok®: temperaturbeständig von -56°C bis +120°C. Nach vorherigem Praxistest sind Anwendungen bis zu +150°C möglich.



6

- Nytemp®: für Hochtemperatur-Schraubensicherung bis 200°C
Dauerbelastung (kurzzeitig auch höhere Belastungen möglich).



7

- TufLok®: trocknet nicht aus, schrumpft nicht, zersetzt sich nicht, ist praktisch unbegrenzt lagerfähig. Es ist beständig gegen Alkohol, Öl, Benzin, und die meisten Verdüner. Die TufLok-Beschichtung ist auch für Lebensmittelbetriebe geeignet.



8

Produktmerkmale

- Hohe Sicherungswirkung im Vergleich zu anderen Verfahren; selbst dann, wenn Schrauben nicht richtig angezogen wurden.
- In jeder Einschraubstellung rüttelfest. Die TufLok-Schraube ist deshalb auch hervorragend geeignet als Justierschraube.



9

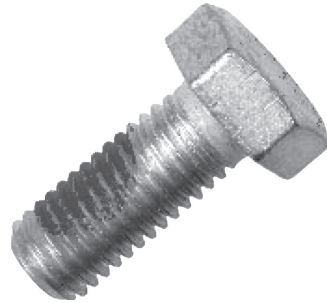

- Dicht gegen Flüssigkeiten und Gase. Die Nylonschicht presst sich fest in die Gewindeflanken ein und hindert dadurch Medien am Eindringen. Für diese Anwendungen wird Rundumbeschichtung empfohlen.
- Ersetzt formschlüssige Sicherungselemente, die in der Montage oft vergessen werden und verlorengehen. Der blaue TufLok-Fleck ist ein unverlierbarer Bestandteil der Schraube.
- Mehrmals wiederverwendbar. Der hochelastische blaue TufLok-Fleck hat das Bestreben, immer wieder die ursprüngliche Form anzunehmen. Seine system-typische Sprührandzone sichert die Auflage gegen Abscheren.
- Keinerlei Aushärtezeit – sofort belastbar. Auch problemlos, wenn die TufLok-Schraube bei der Endmontage nachgezogen wird.
- Für alle metallischen Werkstoffe geeignet, auch für Gewindeteile aus nichtrostenden Stählen, Leichtmetallen und Messing, sowie für fast alle oberflächenveredelten Teile.

Montage

Die Montage einer TufLok-Schraube erfolgt maschinell oder manuell mit herkömmlichen Werkzeugen. Die TufLok-Schraube erhöht die Produktivität, weil sie vollautomatisch zugeführt und eingedreht werden kann. Öl- und Fettfreiheit des Muttergewindes ist nicht notwendig, die Drehmomente werden dadurch jedoch herabgesetzt.

Beschichtung

Die Beschichtung erfolgt nach Werknorm 900.1.

Passivieren verzinkter Schrauben ist auch nach der TufLok-Beschichtung möglich; die Konzentration der Salpetersäure zum Aktivieren der Zinkschicht darf fünf Prozent nicht überschreiten, sie sollte grundsätzlich so gering wie möglich sein.

Optimale Ergebnisse werden erzielt bei einem sauberen, spanfreien und glatten Muttergewinde in mittlerer Toleranzklasse. Ansenken des Muttergewindes wird in der Regel empfohlen.

Das TufLok-System kann in laufende Produktionsserien problemlos und ohne jede Werkstück-Änderung eingesetzt werden.

Sonderwünsche für Lage der Beschichtung und Höhe der Drehmomente können weitgehend berücksichtigt werden.

Prüfung

Die Prüfung erfolgt in der Regel nach WN 900.1.

Andere Prüfmethode müssen immer angegeben werden. Dies können sein:

- DIN 267, Teil 28
- DIN 267, Teil 15
- Kundenprüfteil mit Drehmomentangabe

Gewinde-Beschichtung mit Nylon klemmende Beschichtung

entsprechend DIN 267, Teil 28

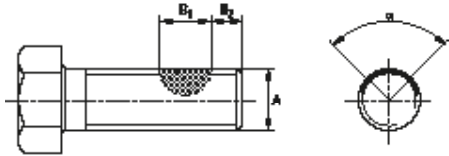

Anwendung

Zur Herstellung von montagefertigen, selbstsichernden und abdichtenden Schrauben und Gewindeteilen von M 0,8 bis M 68, Länge bis 220 mm.

Normalbeschichtung:

Beschichtungswinkel α im Kernbereich 060840 $\approx 90^\circ$, Randzone (Sprüh-Übergang) bis $\approx 180^\circ$. Beschichtungslänge $B_1 \approx 4$ bis 6 Gewindegänge. Etwa 2 bis 3 Gewindegänge bleiben unbebeschichtet für einwandfreies Einschrauben (B2).

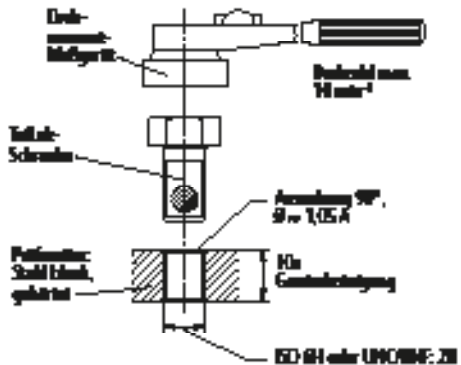

Sichern von Schraubverbindungen

TufLok®/Nytemp® für selbstsichernde Außengewinde

Werknorm 900.1



Drehmomente

Schrauben
ISO 6g

A

bis M 2

M 3

M 3,5

M 4

M 5

M 6

M 8

M 10

M 12

M 14

M 16

M 18

M 20

M 22

M 24

I
Eindrehen

max. Nm

II
erstes Rückdrehen

min. Nm

III
fünftes Rückdrehen

min. Nm

0,2	0,04	0,02
0,45	0,1	0,05
0,7	0,2	0,1
0,9	0,28	0,17
1,6	0,4	0,23
3	0,8	0,4
6	1,5	0,8
9,5	2,3	1,2
13	3,4	1,7
19	4,5	2,3
28	7	3,5
36	9	4
44	11	5,5
60	15	7,5
80	20	10



Drehmoment-Prüfung

1. Vor der Prüfung wird die Toleranzhaltigkeit der Prüfmutter kontrolliert.

2. Schraube in die Prüfmutter eindrehen bis die Beschichtungsstelle innerhalb der Mutter liegt. Dabei das maximale Eindrehmoment messen (max. Werte siehe Tabelle, Spalte I).

3. Schraube um 90° zurückdrehen, dann während der folgenden 360° das größte Drehmoment messen (Sollwert siehe Tabelle, Spalte II).

4. Schraube viermal ganz aus der Prüfmutter herausdrehen und wieder eindrehen. Beim fünften Ausdrehen während der ersten 360° wiederum das größte Drehmoment messen (Sollwert siehe Tabelle, Spalte III).

Die in der Tabelle genannten Werte setzen Schrauben voraus, die hinsichtlich Material und Oberflächengüte homogen sind. Anzugsdrehmomente bei der Prüfung unter

Vorspannung: siehe Angaben des Schraubenerstellers.

Sonderausführungen

Abweichende Beschichtungslängen, Fleck- oder Rundumbeschichtung und/oder andere Beschichtungsstellen. Abweichende Drehmomente sowie Werte für andere Prüfmethode(n) (z. B. mit Prüfmutter entsprechend DIN 267, Teil 28, Ziffer 5.1.2) oder andere Schraubentoleranzen: Probebeschichtung erforderlich.

Neben den Standardfarben blau für TufLok und orange für Nytemp sind für Unterscheidungszwecke (z. B. Zoll/metrisch, unterschiedliche Festigkeitsklassen und für Kennzeichnung von Kleinabmessungen, beispielsweise M1/M1,2) auf Wunsch andere Farben lieferbar.

Die selbstsichernden Innengewinde sind beschichtet mit einer hochelastischen blauen Nylonaufgabe: TufLok® „der blaue Fleck“.

Beim Aufschrauben der Innengewinde bewirkt dieser blaue TufLok-Fleck eine hohe Flächenpressung in den gegenüberliegenden Gewindeflanken.

Außerdem füllt die Nylonschicht den axialen Spielraum zwischen Schrauben- und Muttergewinde aus. Es entsteht eine vibrations sichere Verbindung, die das Losdrehen bei dynamischen Belastungen verhindert, jedoch jederzeit wieder gelöst werden kann.

Anwendungsbereich

Selbstsichernde TufLok-Innengewinde bewähren sich überall in der Industrie, beispielsweise im Kraftfahrzeugbau sowie bei Geräten und Konstruktionen aller Art – vor allem dort, wo Gefahr besteht, dass sich Teile von Maschinen oder Fahrzeugen in Betrieb lösen.



Produktmerkmale

- Mit der TufLok-Innengewindebeschichtung wird eine hohe Sicherungswirkung erreicht.
- Die selbstsichernde TufLok-Mutter lässt sich schnell und einfach montieren, entweder manuell oder mit vollautomatischen Schraubgeräten. Sie ist ideal für genaue Einstellarbeiten.
- Im Gegensatz zu Sicherungsmuttern mit verformtem Gewinde oder mit Verzahnungen vermeidet die TufLok-Mutter alle Oberflächenverletzungen des Werkstücks, das Fressen im Gewinde sowie Abrieb oder Beschädigung des Schraubgewindes.
- Auf zusätzliche Sicherungselemente kann verzichtet werden. Das bedeutet Kosteneinsparungen durch geringeren Aufwand für Lagerhaltung, Disposition und Montage.
- Der „eingebaute Sicherungseffekt“ kann bei der Montage nicht vergessen werden und bei Reparaturarbeiten nicht verlorengehen. Das bedeutet erhöhte Sicherheit.
- Das TufLok-Innengewinde ist wiederverwendbar.
- **TufLok®**: Temperaturbeständig von -56°C bis 150°C.
- **Nytemp®**: für höhere Temperaturbelastungen bis 200°C Dauerbelastung (kurzzeitig auch höhere Belastungen möglich).



Sichern von Schraubverbindungen

TufLok®/Nytemp® für selbstsichernde Innengewinde

Werknorm 945



1

Gewindebeschichtung mit Nylon
klemmende Beschichtung entsprechend DIN EN ISO 2320



2

Anwendung

Für vibrationssichere und dennoch jederzeit lösbare Verschraubungen Normalbeschichtung



3

Fleckbeschichtung

Ein bis zwei Gewindegänge auf jeder Seite bleiben unbeschichtet für das leichte Aufschrauben.



4

Klemmdrehmoment



5

Festigkeitsklasse 5 und 8

Festigkeitsklasse 10 und 12

Gewinde- mutter	Festigkeitsklasse 5 und 8			Festigkeitsklasse 10 und 12		
	erstes Aufschrau- ben max.	erstes Abschrau- ben min.	fünftes Abschrau- ben min.	erstes Aufschrau- ben max.	erstes Abschrau- ben min.	fünftes Abschrau- ben min.
M 5	1,6	0,29	0,2	2,1	0,35	0,24
M 6	3	0,45	0,3	4,0	0,55	0,4
M 8	6	0,85	0,6	8,0	1,15	0,8
M10	10,5	1,5	1	14,0	2,0	1,4
M12	15,5	2,3	1,6	21	3,1	2,1



6



7



8

Für alle metallischen Werkstoffe geeignet, auch für Gewindeteile aus nichtrostenden Stählen, Leichtmetallen und Messing sowie für fast alle oberflächenveredelten Teile.



9

Gewinde

nach DIN 13

Beständigkeit

siehe TufLok-Werknorm 900.1

Sicherung

gemäß DIN EN ISO 2320 (in besonderen Anwendungsfällen durch Versuch zu ermitteln).

Andere Abmessungen und Sonderbeschichtungen (Drehmomente) auf Anfrage.

Neben den Standardfarben blau für TufLok und orange für Nytemp sind für Unterscheidungszwecke (z. B. Zoll/metrisch, unterschiedliche Festigkeitsklassen und für Kennzeichnung von Kleinabmessungen, beispielsweise M1/M1,2) auf Wunsch andere Farben lieferbar.

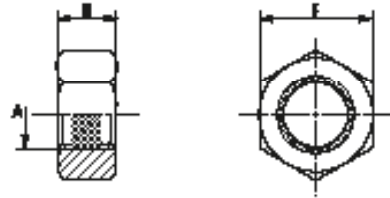

Für besondere Anforderungen und/oder sicherheitsrelevante Einsatzfälle können zusätzliche artikel- oder einsatzspezifische Prüfungen – werksseitig oder durch beauftragte werksunabhängige Sachverständige oder Prüfinstitute – durchgeführt werden. Die Ergebnisse dieser Extraprüfungen werden in einer Prüfbescheinigung dokumentiert, die der Besteller im Original erhält.

Art und Umfang dieser zusätzlichen Prüfungen und wer diese durchführen und dokumentieren soll, hat der Verwender aufgrund seiner Kenntnisse über Einsatz und besonderer Anforderungen zu bestimmen und spätestens entsprechend bei Bestellung vorzugeben. Kosten für zusätzliche Prüfungen sind im Produktpreis nicht enthalten.

Grundsätzliche Hinweise









- Alle benannten Prüfungen werden allgemein als Stichproben durchgeführt. Deren Ergebnisse sind weitgehend repräsentativ für das Lieferlos einer Charge. Sie stellen aber keine Garantie für die Beschaffenheit des jeweiligen Lieferloses der Charge dar. Weiterhin kann aus ihnen nicht auf die Tauglichkeit für einen bestimmten Verwendungszweck gefolgert werden.
- Händler dürfen eigene Bescheinigungen weder nach EN 10204 noch nach DIN 55350-18 ausstellen. Dies ist ausschließlich dem Hersteller bzw. dem beauftragten Sachverständigen vorbehalten.
- Prüfbescheinigungen ersetzen nicht die ordnungsgemäße Wareneingangsprüfung entsprechend §§ 377, 378 HGB beim Besteller (Abnehmer)!

Für den Einsatz in überwachungsbedürftigen Anlagen (z.B. Druck- und Dampfbehälter) sind Art und Umfang durchzuführender Prüfungen und erforderliche Art der Prüfbescheinigung in den Regelwerken AD-W2, W7, W10/TRD 106 vorgegeben.

Zusätzlich besteht die Vorgabe, dass hierfür ausschließlich Schrauben und Muttern von TÜV-anerkannten Herstellern in TÜV-zugelassenen Festigkeitsklassen/Werkstoffen eingesetzt werden dürfen.

Über Arten von Prüfbescheinigungen, nach DIN EN 10204 die sich als Vorgabe für Schrauben, Muttern und ähnliche Form- und Zubehörteile bewährt und durchgesetzt haben, informiert die Tabelle auf der folgenden Seite.



	Norm-Bezeichnung	Bescheinigung	Spezifische Prüfung	Angabe von Prüfungsergebnissen	Inhalt der Bescheinigung	Ausstellung durch
	2.1 ¹	Werksbescheinigung	Nein ¹	Nein	Bestätigung der Übereinstimmung mit der Bestellung	den Hersteller
	2.2 ²	Werkszeugnis	Nein ¹	Ja	Bestätigung der Übereinstimmung mit der Bestellung unter Angabe von Ergebnissen nichtspezifischer Prüfung	den Hersteller
	3.1	Abnahmeprüfzeugnis 3.1	Ja ²	Ja	Bestätigung der Übereinstimmung mit der Bestellung unter Angabe von Ergebnissen spezifischer Prüfung	den von der Fertigungsabteilung unabhängigen Abnahmebeauftragten des Herstellers
	3.2	Abnahmeprüfzeugnis 3.2	Ja ²	Ja	Bestätigung der Übereinstimmung mit der Bestellung unter Angabe von Ergebnissen spezifischer Prüfung	den von der Fertigungsabteilung unabhängigen Abnahmebeauftragten des Herstellers und den vom Besteller beauftragten Abnahmebeauftragten oder den in den amtlichen Vorschriften genannten Abnahmebeauftragten
						
						
						
						

¹ nicht empfehlenswert, da keinerlei spezifische Aussage zum gelieferten Produkt

² spezifische Prüfungen werden an Teilen aus der Liefermenge durchgeführt (die für die zerstörende Prüfungen erforderliche Probenmenge ist bei der Bestellmenge zu berücksichtigen)

DIN	ISO	EN	DIN	ISO	EN	DIN	ISO	EN
1	2339	22339	937	7038		6925	10513	
7	2338	22338	960	8765	28765	7337 VVG	15973-82	
84	1207		961	8676	28676	7343	8750	28750
85	1580		963	2009		7343	8751	28751
94	1234		964	2010		7344	8748	28748
124	1051		965	7046		7346	13337	
125-1	7089		966	7047		7504	15480-83	
125-2	7090		979	7038		7970	1478	
417	7435	27435	980	7042		7971	1481	
427	2342		980	7719		7972	1482	
433-1	7092-1		982	7040		7973	1483	
433-2	7092-2		985	10511		7976	1479	
438	7436	27436	1440	8738	28738	7979	8733	28733
439-1	4036	24036	1443	2340	22340	7979	8735	
439-2	4035	24035	1444	2341	22341	7981	7049	
439-2	4035	28675	1470	8739	28739	7982	7050	
440	7094		1471	8744	28744	7983	7051	
551	4766	24766	1472	8745	28745	7985	7045	
553	7434	27434	1473	8740	28740	7991	10642	
601	4016	24016	1474	8741	28741	9021	7093	
603	8677		1475	8742	28742	9841	7379	
660	1051		1475	8743	28743			
661	1051		1476	8746	28746			
662	1051		1477	8747	28747			
912	4762	24762	1481	8752	28752			
913	4026	24026	6325	8734	28734			
914	4027	24027	6885-1	773				
915	4028	24028	6885-3	2491				
916	4029	24029	6888	3912				
931	4014	24014						
933	4017	24017	6900.1-.5	10644				
934	4032	24032	6901	10510				
935-1	7035		6921	8100	1665			
935-1	7036		6921	8102	1665			
935-3	7037		6921	8104	1665			
936	8675		6923	4161	1661			



ISO – DIN – EN Vergleichstabelle



	ISO	DIN	EN	ISO	DIN	EN	ISO	DIN	EN
1	773	6885-1		7035	935-1		8738	1440	28738
	1051	660		7036	935-1		8739	1470	28739
2	1051	661		7037	935-3		8740	1473	28740
	1207	84		7038	937		8741	1474	28741
	1234	94		7040	982		8742	1475	28742
3	1478	7970		7041	982		8743	1475	28743
	1479	7976		7042	980		8744	1471	28744
	1481	7971		7043	6926		8745	1472	28745
	1482	7972		7045	7985		8746	1476	28746
4	1483	7973		7046	965		8747	1477	28747
	1580	85		7047	966		8750	7343	28750
	2009	963		7049	7981		8751	7343	28751
5	2010	964		7050	7982		8752	1481	28752
	2338	7	22338	7051	7983		8765	960	28765
	2339	1	22339	7089	125-1		10510	6901	
6	2340	1443	22340	7090	125-2		10511	985	
	2341	1444	22341	7092	433		10513	6925	
	2342	427		7092 -1	433-1		10642	7991	
	2491	6885-3		7092 -2	433-2		10644	6900.1 - .5	
7	2492	6883 / 6884		7093	9021		13337	7346	
	3912	6888		7094	440		14583	7985 TZD	
	4014	931	24014	7379	9841		15480-83	7504	
8	4016	601	24016	7434	553	27434	15973-82	7337	
	4017	933	24017	7435	417	27435			
	4018	558	24018	7719	980				
	4026	913	24026	8100	6921	1665			
	4027	914	24027	8102	6921	1665			
	4028	915	24028	8104	6921	1665			
	4029	916	24029	8673	934 Feing.	28673			
	4032	934	24032	8675	936				
	4035	439-2	24035	8676	961	28676			
	4035	439-2	28675	8677	603				
	4036	439-1	24036	8733	7979				
	4161	6923	1661	8734	6325	28734			
	4762	912	24762	8735 A	7979 D				
	4766	551	24766	8735 B	7979 C				

EN	DIN	ISO	EN	DIN	ISO	EN	DIN	ISO
1661	6923	4161	24029	916	4029	28740	1473	8740
1665	6921	8100	24032	934	4032	28741	1474	8741
1665	6921	8102	24035	439-2	4035	28742	1475	8742
1665	6921	8104	24036	439-1	4036	28743	1475	8743
22338	7	2338	24762	912	4762	28744	1471	8744
22339	1	2339	24766	551	4766	28745	1472	8745
22340	1443	2340	27434	553	7434	28746	1476	8746
22341	1444	2341	27435	417	7435	28747	1477	8747
24014	931	4014	28675	439-2	4035	28750	7343	8750
24017	933	4017	28676	961	8676	28751	7343	8751
24026	913	4026	28734	6325	8734	28752	1481	8752
24027	914	4027	28738	1440	8738	28765	960	8765
24028	915	4028	28739	1470	8739			





DIN 1 Kegelstifte	396-397	DIN 438 Gewindestifte mit Schlitz und Ringschneide	75
DIN 7 Zylinderstifte ungehärtet	398-399	DIN 439 Sechskantmuttern niedrige Form	267
DIN 39 Feste Ballengriffe Form E: mit Gewindezapfen	460	DIN 440 Scheiben für vorwiegend Holzkonstruktionen	337
DIN 84 Zylinderkopfschrauben mit Schlitz	64-65	DIN 444 Augenschrauben	76-77
DIN 85 Flachkopfschrauben mit Schlitz	66-67	DIN 462 Sicherungsbleche mit Innennase	338
DIN 93 Scheiben mit Lappen	324	DIN 463 Sicherungsbleche mit 2 Lappen	339
DIN 94 Splinte	442-443	DIN 464 Rändelschrauben hohe Form	78
DIN 95 Holzschrauben mit Linsensenkopf und Schlitz	68	DIN 466 Rändelmuttern hohe Form	268
DIN 96 Holzschrauben mit Halbrundkopf und Schlitz	69	DIN 467 Rändelmuttern niedrige Form	269
DIN 97 Holzschrauben mit Senkkopf und Schlitz	70	DIN 470 Verschlusscheiben	340
DIN 99 Kegelgriff Form L + N	461	DIN 471 Sicherungsringe für Wellen	341-342
DIN 125 Scheiben	325	DIN 472 Sicherungsringe für Bohrungen	343-344
DIN 126 Scheiben	326	DIN 479 Vierkantschrauben mit Kernansatz	79
DIN 127 Federringe	327	DIN 480 Vierkantschrauben mit Bund	80
DIN 128 Federringe Form A: gewölbt	328	DIN 508 T-Nutensteine	270
DIN 134 Scheiben	329	DIN 525 Anschweißenden	81
DIN 137 Federscheiben Form A	330	DIN 529 Steinschrauben Form C	82
DIN 137 Federscheiben Form B	331	DIN 546 Schlitzmuttern	271
DIN 267 klebende Beschichtung	584	DIN 547 Zweilochmuttern	272
DIN 315 Flügelmuttern „Deutsche“ Form	264	DIN 548 Kreuzlochmuttern	273
ähnl. DIN 315 Flügelmuttern (klein) „Amerikanische“ Form	265	DIN 551 Gewindestifte mit Schlitz und Kegelkuppe	83
DIN 316 Flügelschrauben	71	DIN 553 Gewindestifte mit Schlitz und Spitze	84
DIN 319 Kugelknöpfe Form E: mit Gewindebuchse	462-463	DIN 557 Vierkantmuttern	274
DIN 404 Kreuzlochschrauben	72	DIN 561 Sechskantschrauben mit Zapfen	85
DIN 417 Gewindestifte mit Schlitz und Zapfen	73	DIN 562 Vierkantmuttern niedrige Form	275
DIN 427 Schaftschrauben mit Schlitz und Kegelkuppe	74	DIN 564 Sechskantschrauben mit Ansatzspitze	86-87
DIN 431 Rohrmuttern	266	DIN 571 Sechskant-Holzschrauben	88-89
DIN 432 Scheiben mit Außennase	332	DIN 580 Ringschrauben	90-91
DIN 433 Scheiben kleiner Außendurchmesser	333	DIN 582 Ringmuttern	276-277
DIN 434 Scheiben vierkant, Keilförmig für U-Träger	334	DIN 601 Sechskantschrauben mit Schaft	92-93
DIN 435 Scheiben vierkant, keilförmig für I-Träger	335	DIN 603 Flachrundschrauben mit Vierkantansatz	94-95
DIN 436 Scheiben vierkant für Holzkonstruktionen	336	DIN 604 Senkschrauben mit Nase	96-97
		DIN 605 Senkschrauben mit hohem Vierkantansatz	98-99
		DIN 608 Senkschrauben mit niedrigem Vierkantansatz	100-101



Stichwortverzeichnis

nach DIN



	1	DIN 609 Passschrauben mit Sechskant und langen Gewindezapfen	102-103	DIN 936 Sechskantmuttern niedrige Form	283
	2	DIN 610 Passschrauben mit Sechskant und kurzen Gewindezapfen	104-105	DIN 937 Kronenmuttern niedrige Form	284
	3	DIN 653 Rändelschrauben niedrige Form	106-107	DIN 938 Stiftschrauben Einschraubende ca. 1 X D	136-137
	4	DIN 660 Halbrundnieten	454	DIN 939 Stiftschrauben Einschraubende ca. 1,25 X D	138-139
	5	DIN 661 Senknieten	455	DIN 960 Sechskantschrauben mit Schaft und metrischem Feingewinde	140-141
	6	DIN 705 Stellringe Form A	345	DIN 961 Sechskantschrauben mit Gewinde bis Kopf und metrischem Feingewinde	142-143
	7	DIN 741 Drahtseilklemmen	464	DIN 963 Senkschrauben mit Schlitz	144-145
	8	DIN 787 T-Nutenschraube	108-109	DIN 964 Linsensenkschrauben mit Schlitz	146-147
	9	DIN 835 Stiftschrauben Einschraubende ca. 2 X D	110-111	DIN 965 Senkschrauben mit Kreuzschlitz	148-149
		DIN 906 Verschlusschrauben mit kegeligem Gewinde und Innensechskant	112-113	DIN 966 Linsensenkschrauben mit Kreuzschlitz	150-151
		DIN 908 Verschlusschrauben mit Bund und Innensechskant	114-115	DIN 976 Gewindestangen	152-153
		DIN 910 Verschlusschrauben mit Bund und Außensechskant	116-117	DIN 979 Sechskantkronenmuttern niedrige Form	285
		DIN 911 Stiftschlüssel	465	DIN 980 Sechskantmuttern mit Klemmteil Ganzmetallmuttern	286
		DIN 912 Zylinderschrauben mit Innensechskant	118-119	DIN 981 Nutmuttern für Wälzlager	287-288
		DIN 913 Gewindestifte mit Innensechskant und Kegelhülse	120-121	DIN 982 Sechskantmuttern mit Klemmteil, nichtmetallischer Einsatz, hohe Form	289
		DIN 914 Gewindestifte mit Innensechskant und Spitze	122-123	DIN 985 Sechskantmuttern mit Klemmteil, nichtmetallischer Einsatz	290
		DIN 915 Gewindestifte mit Innensechskant und Zapfen	124-125	DIN 986 Sechskant-Hutmuttern mit Klemmteil, nichtmetallischer Einsatz	291
		DIN 916 Gewindestifte mit Innensechskant und Ringschneide	126-127	DIN 988 Passscheiben	348-349
		DIN 917 Sechskant-Hutmuttern niedrige Form	278	DIN 988 Stützscheiben	346-347
		DIN 920 Flachkopfschrauben mit Schlitz und kleinem Kopf	128	DIN 1052 Scheiben großer Außendurchmesser für Holzbau	350
		DIN 921 Flachkopfschrauben mit Schlitz und großem Kopf	129	DIN 1144 Leichtbauplattenstift	400
		DIN 923 Flachkopfschrauben mit Schlitz und Ansatz	130	DIN 1151 Drahtstifte mit Senkkopf	401
		DIN 927 Zapfenschrauben mit Schlitz	131	DIN 1152 Drahtstifte mit Stauchkopf	402
		DIN 928 Vierkant-Schweißmuttern	279	DIN 1433 Bolzen ohne Kopf, Ausführung m	444
		DIN 929 Sechskant-Schweißmuttern	280	DIN 1434 Bolzen kleiner Kopf, Ausführung m	445
		DIN 931 Sechskantschrauben mit Schaft	132-133	DIN 1435 Bolzen kleiner Kopf, Ausführung mg	446
		DIN 933 Sechskantschrauben mit Gewinde bis Kopf	134-135	DIN 1436 Bolzen großer Kopf, Ausführung mg	447
		DIN 934 Sechskantmuttern	281	DIN 1440 Scheiben Ausführung mittel für Bolzen	351
		DIN 935 Kronenmuttern	282	DIN 1441 Scheiben Ausführung grob für Bolzen	352
				DIN 1470 Zylinderkerbstifte mit Einführende	403



DIN 1471 Kegelkerbstifte	404	DIN 6887 Nasenkeile	422
DIN 1472 Passkerbstifte	405	DIN 6912 Zylinderschrauben mit Innensechskant niedriger Kopf	154–155
DIN 1473 Zylinderkerbstifte mit Fase	406–407	DIN 6917 HV-Vierkantscheiben I-Profil	365
DIN 1474 Steckkerbstifte	408	DIN 6918 HV-Vierkantscheiben U-Profil	366
DIN 1475 Knebelkerbstifte mit kurzen Kerben	409	DIN 6921 Sechskantschrauben mit Flansch	156
DIN 1476 Halbrundkerbnägel	410	DIN 6923 Sechskantmuttern mit Flansch	302
DIN 1477 Senkkerbnägel	411	DIN 6924 Sechskantmuttern mit Klemmteil nichtmetallischer Einsatz	303
DIN 1478 Spannschlösser aus Stahlrohr	292	DIN 6925 Sechskantmuttern mit Flansch und Klemmteil ganzmetall	304
DIN 1479 Spannschlossmuttern aus Sechskantstahl	293	DIN 6926 Sechskantmuttern mit Flansch und Klemmteil nichtmetallischer Einsatz	305
DIN 1480 Spannschlösser geschmiedet (offene Form)	294	DIN 7337 Blindnieten Form A: Flachkopf	456
DIN 1587 Sechskant-Hutmuttern hohe Form	295	DIN 7337 Blindnieten Form B: Senkkopf	457
DIN 1804 Nutmuttern	296–297	DIN 7346 Spannhülse leichte Ausführung	424–425
DIN 1816 Kreuzlochmuttern	298	DIN 7349 Scheiben für Schrauben mit schweren Spannhülsen	367
DIN 2093 Tellerfedern	353–355	DIN 7500-C Gewindefurchende Schrauben mit Linsenkopf	157
DIN 3570 Rundstahlbügel Form A	466	DIN 7500-D Gewindefurchende Schrauben mit Sechskantkopf	158
DIN 5406 Sicherungsbleche für Nutmuttern	356–357	DIN 7500-E Gewindefurchende Schrauben mit Zylinderkopf	159
DIN 5685 Ketten	485	DIN 7500-M Gewindefurchende Schrauben mit Senkkopf	160
DIN 6325 Zylinderstifte gehärtet und geschliffen	412–413	DIN 7504-K Blechbohrschrauben mit Sechskant	161
DIN 6330 Sechskantmuttern 1,5 d hoch	299	DIN 7504-N Blechbohrschrauben mit Flachkopf und Kreuzschlitz	162–163
DIN 6331 Sechskantmuttern 1,5 d hoch mit Bund	300	DIN 7504-P Blechbohrschrauben mit Senkkopf und Kreuzschlitz	164
DIN 6334 Verlängerungsmuttern mit Sechskant, 3 X D hoch	301	DIN 7504, Verarbeitung von Blechbohrschrauben	579
DIN 6335 Kreuzgriffe Form K: mit Gewindebuchse	467	DIN 7513-A Gewinde-Schneidschrauben mit Sechskantkopf	165
DIN 6336 Sterngriffe Form K: mit Gewindebuchse	468–469	DIN 7513-B Gewinde-Schneidschrauben mit Zylinderkopf	166
DIN 6340 Scheiben für Spannzeuge	358	DIN 7513-F Gewinde-Schneidschrauben mit Senkkopf	167
DIN 6796 Spannscheiben für Schraubenverbindungen	359	DIN 7516-A Gewinde-Schneidschrauben mit Linsenkopf	168
DIN 6797 Zahnscheiben Form A / Form I	360	DIN 7516-D Gewinde-Schneidschrauben mit Linsensenkkopf	169
DIN 6797 Zahnscheiben Form V	361		
DIN 6798 Fächerscheiben Form A / Form I	362		
DIN 6798 Fächerscheiben Form V	363		
DIN 6799 Sicherungsscheiben für Wellen	364		
DIN 6885 Passfedern Form A, rundstirnig	414–421		
DIN 6888 Scheibenfedern	423		
DIN 6899 Kauschen Form A	470		



Stichwortverzeichnis

nach DIN



	1	DIN 7603 Dichtringe Form A	368-370	DIN EN 14399, Anziehdrehmomente für HV-Garnituren	574
	2	DIN 7965 Einschraubmuttern	488-489	DIN EN 14399 Scheiben für HV-Verbindungen	377
	3	DIN 7971 Blechschrauben mit Flachkopf und Schlitz	170	DIN EN 14399 Sechskantmuttern für HV-Verbindungen	311
	4	DIN 7972 Blechschrauben mit Senkkopf und Schlitz	171	DIN EN 14399 Sechskantschrauben für HV-Verbindungen	196-197
	5	DIN 7973 Blechschrauben mit Linsensenkkopf und Schlitz	172	DIN EN 15048, Anziehdrehmomente von SB-Garnituren	575
	6	DIN 7976 Blechschrauben mit Sechskant	173	DIN EN 15048 SB-Garnituren	190-191
	7	DIN 7977 Kegelstifte mit Gewindepapfen	426-427	DIN EN 20898 Mechanische Eigenschaften von Muttern	518
	8	DIN 7978 Kegelstifte mit Innengewinde	428-429	DIN 14440 Thermagmuttern (normale SW)	307
	9	DIN 7979 Zylinderstifte mit Innengewinde	430-431	DIN 14441 Thermagmuttern (verringerte SW)	308
		DIN 7980 Federringe für Zylinderschrauben	371	DIN 50900 Korrosion	556
		DIN 7981 Blechschrauben mit Flachkopf und Kreuzschlitz	174	DIN 50961 Passivieren, Dickschicht	563
		DIN 7982 Blechschrauben mit Senkkopf und Kreuzschlitz	175	DIN 70852 Nutmuttern	309
		DIN 7983 Blechschrauben mit Linsensenkkopf und Kreuzschlitz	176-177	DIN 71751 Gabelgelenke Form A: mit Splintbolzen	471
		DIN 7984 Zylinderschrauben mit Innensechskant und niedrigem Kopf	178-179	DIN 71752 Gabelköpfe für Gabelgelenke	472
		DIN 7985 Flachkopfschrauben mit Kreuzschlitz	180-181	DIN 82101 Schäkel	473
		DIN 7989 Scheiben für Stahlkonstruktionen	372	ISO 272 neue Schlüsselweiten	528
		DIN 7990 Anziehdrehmoment von SB-Garnituren	575	ISO 898 Mechanische Eigenschaften von Muttern	519
		DIN 7990 Sechskantschrauben mit 6kt-Mutter für Stahlkonstruktion	182-185	ISO 2320 klemmende Beschichtung	590
		DIN 7991 Senkschrauben mit Innensechskant	186-187	ISO 4014 Sechskantschrauben mit Schaft	189
		DIN 7993 Runddrahtsprengringe für Bohrungen (Form B)	375	ISO 4017 Sechskantschrauben mit Gewinde bis Kopf	189
		DIN 7993 Runddrahtsprengringe für Wellen (Form A)	373-374	ISO 4032 Sechskantmuttern	410
		DIN 7995 Linsensenkholzschrauben mit Kreuzschlitz	188	ISO 4042 Galvanische Überzüge	560-561
		DIN 8140 Gewindeeinsätze	490-492	ISO 7379 Schulterpassschrauben mit Innensechskant	192
		DIN 9021 Scheiben, Außendurchmesser = 3 X Gewindedurchmesser	376	ISO 7380 Flachkopfschraube mit Innensechskant	193
		DIN EN 10204 Prüfbescheinigungen	591-592	ISO 7380F Linsenflanschschrauben mit Innensechskant	194-195
		DIN 11024 Federstecker	448	ISO 8044 Korrosion	556
				ISO 8739 Zylinderkerbstifte mit Einführende	403
				ISO 8740 Zylinderkerbstifte mit Fase	406-407
				ISO 8741 Steckkerbstifte	408
				ISO 8742 Knebelkerbstifte mit kurzen Kerben	409













ISO 8744 Kegelkerbstifte	404	KX160 Fassadenbauschrauben mit EPDM-Dichtscheibe 16 mm	222
ISO 8745 Passkerbstifte	405	N0001 Flachkopfschraube Typ KF	223
ISO 8746 Halbrundkerbnägel	410	N0010 Sechskantschutzkappen	474
ISO 8747 Senkkerbnägel	411	N0030 Kotflügelscheiben	379
ISO 8748 Spiralspannstifte schwere Ausführung	432-433	N0040 Klappsplinte mit rundem Federring	449
ISO 8750 Spiralspannstifte Normale Ausführung	434-435	N0041 Rohrklappsplinte	450
ISO 8752 Spannstifte geschlitzte, schwere Ausführung	436-437	N0070 Schutzkappe für Innensechskantschrauben	475
ISO 8839 Mechanische Eigenschaften von Nichteisenmetallen	524	N0080 Rosetten	380
ISO 10642 Senkschraube mit Innensechskant	186	N0082 Rosetten, vollmetall	381
ISO 10683 Zinklamellenüberzüge	562, 566-567	N0090 Rückwandschrauben	224
ISO 10684 Feuerverzinken	563-564	N0100 Schnellbauschrauben mit Doppelgang-Feingewinde	225
ISO 14580 Zylinderschrauben mit Innensechsrund	200	N0100 Schnellbauschrauben mit Grobgewinde	226
ISO 14581 Senkschrauben mit Innensechsrund	201	N0100 Schnellbauschrauben mit Bohrspitze	227
A001 Ringschrauben	202-203	N0110 Schnorr Sicherungsscheiben	382-383
A002 Starke Ringschrauben	204	N0115 Nord-Lock Sicherungsscheiben	384-385
A003 Sturmhakenösen	205	N0120 Stockschrauben	228
A004 Gerade Schraubhaken	206	N0125 Sperrkantscheiben Form M	386
A004E Gerade Schraubhaken mit ISO-Gewinde	207	N0128 Sperrkantringe Form K	387
A007 Schlitzschraubhaken	208	N0153 Hülsenmutter mit Senkkopf und Innensechskant	500
A011 Gebogene Schraubhaken	209	N0160 Hülsenmutter mit Linsensenkkopf und Schlitz	501
A011E Gebogene Schraubhaken mit ISO-Gewinde	210	N0163 Rundmutter Typ RF	502
A013 Kronleuchterhaken	211	N0175 Rundmutter Typ RTL	503
A015 Wäscheleinenhaken	212	N0203 Federnde Druckstücke mit Kugel und Innensechskant	476-477
A017 Deckenhaken	213	N0205 Federnde Druckstücke mit Kugel und Schlitz	478-479
A048 Ringschrauben	214-215	N0206 Federnde Druckstücke mit Innensechskant	480
ART55 Kontaktscheibe, gezahnt	378	N0208 Federnde Druckstücke glatte Ausführung mit Bund	481
Ensat Typ 302		N0240 Federstecker Form 1: einfach gewunden	451
Gewindeeinsätze selbstschneidend	493	N0240 Federstecker Form 4: doppelt gewunden	452
Ensat Typ 307		N0250 Stahlnägel mit Längsriffelung	438
Gewindeeinsätze selbstschneidend	494-495	N0260 Drallhaftschrauben	439
Ensat Typ 308			
Gewindeeinsätze selbstschneidend lang	496-497		
Halben Schrauben für Montageschienen	216-221		
Halben Gewindeplatten für Montageschienen	312-313		



Stichwortverzeichnis

nach DIN



	1	N0300 L-Einschlagmutter	314	TOPIX Holzbauschrauben	
		N0301 L-Anschweißmuttern	315	mit Sechskantkopf und T-Drive	261
		N0302 Setzmuttern	316	W1411 Schrauben für Kunststoff	
	2	N0365 Federklappbolzen		mit Flachkopf und Flansch	240
		passend zu DIN 71752	482	W1412 Schrauben für Kunststoff	
		N0370 Distanzmuffen rund,		mit Flachkopf (Kreuzschlitz)	241
		Innengewinde	504	W1413 Schrauben für Kunststoff	
	3	N0371 Verlängerungsmuffen mit Sechskant	505-506	mit Senkkopf (Kreuzschlitz)	242
		N0372 Reduziermuffen		mit Senkkopf und Innensechsrund	245
		mit Innen-/Innengewinde	507	W1423 Schrauben für Kunststoff	
		N0373 Distanzbolzen		mit Senkkopf und Innensechsrund	243
	4	mit Innen-/Außengewinde	508-511	W1451 Schrauben für Kunststoff	
		N0400 Greifringe	388	Flachkopf mit Flansch und Innensechsrund	243
		N0400 Halbmondringe	389	W1452 Schrauben für Kunststoff	
		N0400 Klemmscheiben	390	mit Flachkopf und Innensechsrund	244
	5	N0410 LAMA-Rändelköpfe	483	WN55 Spanplattenschrauben	
		N0430 LAMA-Flügelköpfe	484	mit Linsensenkkopf und Kreuzschlitz	246
		N0440 Käfigmuttern	317	WN56 Spanplattenschrauben	
		N0450 DUBO-Sicherungen	391-392	mit Rundkopf und Kreuzschlitz	247
	6	N0480 Becherschrauben	229	WN57 Spanplattenschrauben	
		N0492 Spenglerschrauben	230	mit Senkkopf und Innensechsrund	250-251
		N0750 Ketten nach DIN 5685	485	WN57 Spanplattenschrauben	
		N0912 Blechschrauben mit Zylinderkopf		mit Senkkopf und Kreuzschlitz	248-249
	7	und Innensechskant	231		
		N0934 Trapezgewindemuttern	318-319		
		NFE25511 Kontaktscheiben	393		
		P151 Sperrzahn-Schrauben	236-237		
	8	P158 Ripp-Schrauben mit Sechskantkopf	238		
		P193 Ripp-Muttern	321		
		P196 Sperrzahn-Muttern	322		
		P251 Inbus-Ripp-Schrauben	239		
	9	S934 Abreißmuttern	320		
		S7380 Flachrundkopfschrauben mit TORX-Pin	232		
	S7981 Blechschrauben				
	mit Flachrundkopf und TORX-Pin	233			
	S7982 Blechschrauben				
	mit Senkkopf und TORX-Pin	234			
	S7991 Senkkopfschrauben				
	mit Innensechskant-Pin	235			
	TOPIX Holzbauschraube				
	mit Senkkopf und T-Drive	252-257			
	TOPIX Holzbauschrauben				
	mit Tellerkopfschraube und T-Drive	258-260			

O...9

3 X D Scheiben, DIN 9021 376

A

Abdeckkappen für Innensechskant N0070 475

Abdeckkappen, sechskant, N0010 474

Abreißmutter, S934 320

Abstandsbolzen, N0373 508

Amerikanische Flügelmutter, DIN 315 265

Anschweißenden, DIN 525 81

Anschweißmutter, N0301 315

Antriebe und Schlüsselweiten 527-531

Anziehdrehmomente 568

Anziehdrehmomente für Feingewindeschrauben, Stahl 576

Anziehdrehmomente für HV-Garnituren 574

Anziehdrehmomente für SB-Garnituren 575

Anziehdrehmomente, Messing 577

Anziehdrehmomente, Polyamid PA 6.6 577

Anziehdrehmomente, nicht rostender Stahl 572-573

Anziehdrehmomente, Stahl 570-571

Augenschrauben, DIN 444 76-77

Auspuff-Schlitzmutter

DIN 14440, DIN14441 307-308

B

Ballengriffe, feste, DIN 39 460

Becherschrauben, N0480 229

Beschichtungen, sichernde 582-590

Beschichtungen 559-564

Bezeichnungssystem

von Schrauben und Muttern 517, 521

Blechbohrschrauben mit Flachkopf

und Kreuzschlitz, DIN 7504-N 162-163

Blechbohrschrauben

mit Sechskant, DIN 7504-K 161

Blechbohrschrauben

mit Senkkopf und Kreuzschlitz, DIN 7504-P 164

Blechbohrschrauben, Verarbeitung 579

Blechschraben

mit Flachkopf und Kreuzschlitz, DIN 7981 174

Blechschraben

mit Flachkopf und Schlitz, DIN 7971 170

Blechschraben mit Flachrundkopf und TORX-Pin, S7981 233

Blechschraben mit Linsensenkkopf und Kreuzschlitz, DIN 7983 176-177

Blechschraben mit Linsensenkkopf und Schlitz, DIN 7973 172

Blechschraben mit Sechskant, DIN 7976 173

Blechschraben

mit Senkkopf und Kreuzschlitz, DIN 7982 175

Blechschraben

mit Senkkopf und Schlitz, DIN 7972 171

Blechschraben

mit Senkkopf und TORX-Pin, S7982 234

Blechschraben mit Zylinderkopf

und Innensechskant, N0912 231

Blechschraben, Kernlöcher 578-579

Blindnieten Form A: Flachkopf, DIN 7337 456

Blindnieten Form B: Senkkopf, DIN 7337 457

Bohrschrauben siehe Blechbohrschrauben

Bohrschrauben, Verarbeitung 579

Bohrungsringe, DIN 472 343-344

Bolzen, großer Kopf, Ausführung mg, DIN 1436 447

Bolzen, kleiner Kopf, Ausführung m, DIN 1434 445

Bolzen, kleiner Kopf, Ausführung mg, DIN 1435 446

Bolzen, ohne Kopf, Ausführung m, DIN 1433 444

Bügelsschrauben,

Rundstahl Form A, DIN 3570 466

C

CE-Kennzeichen 547

Chemische Zusammensetzung von austenitischen Stählen (Auswahl) 523

D

Deckenhaken, A017 213

Deutsche Flügelmutter, DIN 315 264

Dichtringe Form A, DIN 7603 368-370

DIN-ISO-EN Vergleichslisten 593-595

Distanzbolzen

mit Innen-/Außengewinde, N0373 508-511

Distanzmuffen,









rund mit Innengewinde, N0370 504

Distanzscheiben, DIN 988 346

Draht-Gewindeeinsätze, DIN 8140 490-492









Drahtseilklemmen, DIN 741 464



	Drahtstifte mit Senkkopf, DIN 1151	401	Federstecker	
	Drahtstifte mit Stauchkopf, DIN 1152	402	Form 1: einfach gewunden, N0240	451
	Drallhaftnägel, N0260	439	Federstecker	
	Drallhaftschrauben, N0260	439	Form 4: doppelt gewunden, N0240	452
	Drehmomenttabellen siehe Anziehdrehmomente		Feste Ballengriffe	
	Druckstücke, federnd		Form E: mit Gewindepapfen, DIN 39	460
	glatte Ausführung mit Bund, N0208	481	Festigkeitsklassen von Muttern	518
	Druckstücke, federnd		Feuerverzinken, DIN EN ISO 10684	563-564
	mit Innensechskant, N0206	480	Flachkopfschrauben	
	Druckstücke, federnd		mit Innensechskant, ISO 7380	193
	mit Kugel und Innensechskant, N0203	476-477	Flachkopfschrauben Typ KF, N0001	223
	Druckstücke, federnd		Flachkopfschrauben	
	mit Kugel und Schlitz, N0205	478-479	mit Kreuzschlitz, DIN 7985	180-181
	DUBO-Sicherungen, N0450	391-392	Flachkopfschrauben mit Schlitz, DIN 85	66-67
	E		Flachkopfschrauben	
	Einpressmuttern, N0302	316	mit Schlitz und Ansatz, DIN 923	130
	Einschlagmuttern, N0300	314	Flachkopfschrauben mit Schlitz	
	Einschraubmuttern, DIN 7965	488-489	und großem Kopf, DIN 921	129
	Ensat Typ 302	493	Flachkopfschrauben mit Schlitz	
	Ensat Typ 307	494-495	und kleinem Kopf, DIN 920	128
	Ensat Typ 308	496-497	Flachrundkopfschrauben	
	F		mit TORX-Pin, S7380	232
	Fächerscheiben Form A / Form I, DIN 6798	362	Flachrundschrauben	
	Fächerscheiben Form V, DIN 6798	363	mit Vierkantansatz, DIN 603	94-95
	Fassadenbauschrauben		Flanschmuttern, DIN 6923	302
	mit EPDM-Dichtscheibe 16 mm, KX160	222	Flanschschrauben, DIN 6921	156
	Federklappbolzen		Flügelköpfe, N0430	484
	passend zu DIN 71752, N0365	482	Flügelmuttern (klein)	
	Federn für Nut, DIN 6885, DIN 6888	414, 423	„Amerikanische“ Form, DIN 315	265
	Federnde Druckstücke,		Flügelmuttern „Deutsche“ Form, DIN 315	264
	glatte Ausführung mit Bund, N0208	481	Flügelschrauben, DIN 316	71
	Federnde Druckstücke		G	
	mit Innensechskant, N0206	480	Gabelgelenke	
	Federnde Druckstücke mit Kugel		Form A: mit Splintbolzen, DIN 71751	471
	und Innensechskant, N0203	476-477	Gabelköpfe für Gabelgelenke, DIN 71752	472
	Federnde Druckstücke mit Kugel		Galvanische Überzüge, ISO4042	560-561
	und Schlitz, N0205	478-479	Ganzmetallmuttern, DIN 980	286
	Federringe, DIN 127	327	Gebogene Schraubhaken, A011	209
	Federringe Form A: gewölbt, DIN 128	328	Gebogene Schraubhaken	
	Federringe für Zylinderschrauben, DIN 7980	371	mit ISO-Gewinde, A011E	210
	Federscheiben Form A, DIN 137	330	GEOMET® 500	566-567
	Federscheiben Form B, DIN 137	331	Gerade Schraubhaken, A004	206
	Federstecker, DIN 11024	448	Gerade Schraubhaken	
			mit ISO-Gewinde, A004E	207









Gewinde, Begriffe und Arten	548-551	Gewindetoleranzen	552-553
Gewindebuchsen, DIN 8140	490-492	Gezahnte Kontaktscheiben, ART55	378
Gewindeeinsätze, selbstschneidend, Ensat Typ 307	494-495	Gipsplattenschrauben siehe Schnellbauschrauben	
Gewindeeinsätze, selbstschneidend, Ensat Typ 308	496-497	Greifringe, N0400	388
Gewindeeinsätze, selbstschneidend lang, Ensat Typ 302	493	H	
Gewindefurchende Schrauben mit Linsenkopf, DIN 7500-C	157	Haken	206-210, 213
Gewindefurchende Schrauben mit Sechskantkopf, DIN 7500-D	158	Halbmondringe, N0400	389
Gewindefurchende Schrauben mit Senkkopf, DIN 7500-M	160	Halbrundkerbnägel, DIN 1476	410
Gewindefurchende Schrauben mit Zylinderkopf, DIN 7500-E	159	Halbrundkerbnägel, ISO 8746	410
Gewindeplatten für Montageschienen	312-313	Halbrundnieten, DIN 660	454
Gewinde-Schneidschrauben mit Linsenkopf, DIN 7516-A	168	Halben Gewindeplatten	312-313
Gewinde-Schneidschrauben mit Linsensenkkopf, DIN 7516-D	169	Halben Schrauben	216-221
Gewinde-Schneidschrauben mit Sechskantkopf, DIN 7513-A	165	Hammerkopfschrauben	108-109, 216-221
Gewinde-Schneidschrauben mit Senkkopf, DIN 7513-F	167	Hammermuttern, DIN 508	270, 312-313
Gewinde-Schneidschrauben mit Zylinderkopf, DIN 7513-B	166	Holzbauschrauben, DIN 1052	350
Gewindestangen, DIN 976	152-153	Holzbauschrauben mit Senkkopf und T-Drive, TOPIX	252-257
Gewindesteigungen	554-555	Holzbauschrauben mit Sechskantkopf und T-Drive, TOPIX	261
Gewindestifte mit Innensechskant und Kegelhülse, DIN 913	120-121	Holzbauschrauben mit Tellerkopf und T-Drive, TOPIX	258-260
Gewindestifte mit Innensechskant und Ringschneide, DIN 916	126-127	Holzschrauben mit Halbrundkopf und Schlitz, DIN 96	69
Gewindestifte mit Innensechskant und Spitze, DIN 914	122-123	Holzschrauben mit Linsensenkkopf und Kreuzschlitz, DIN 7995	188
Gewindestifte mit Innensechskant und Zapfen, DIN 915	124-125	Holzschrauben mit Linsensenkkopf und Schlitz, DIN 95	68
Gewindestifte mit Schlitz und Kegelhülse, DIN 551	83	Holzschrauben mit Senkkopf und Schlitz, DIN 97	70
Gewindestifte mit Schlitz und Ringschneide, DIN 438	75	Holzschrauben, sechskant, DIN 571	88-89
Gewindestifte mit Schlitz und Spitze, DIN 553	84	Hülsenmuttern mit Senkkopf und Innensechskant, N0153	500
Gewindestifte mit Schlitz und Zapfen, DIN 417	73	Hülsenmuttern mit Linsensenkkopf und Schlitz, N0160	501
Gewindestücke, DIN 976	152-153	Hutmuttern, hohe Form, DIN 1587	295
		Hutmuttern mit Klemmteil, sechskant, nichtmetallischer Einsatz, DIN 986	291
		Hutmuttern, niedrige Form, DIN 917	278
		HV-Garnituren, Anziehdrehmomente	574
		HV-Garnituren, DIN EN 14399	198-199, 266, 320
		HV-Muttern, DIN EN 14399	311
		HV-Scheiben, DIN EN 14399	377
		HV-Schrauben, DIN EN 14399	196-197



	1	HV-Vierkantscheiben I-Profil, DIN 6917	365	Korrosionsbeständigkeit	565
		HV-Vierkantscheiben U-Profil, DIN 6918	366	Korrosionsschutz, allgemein	558
		I		Kotflügelscheiben, N0030	379
	2	Inbus-Ripp-Schrauben, P251 239		Kreuzgriffe Form K: mit Gewindebuchse, DIN 6335	467
		Inbus-Schrauben, DIN 912 118-119		Kreuzlochmuttern, DIN 1816	298
		K		Kreuzlochmuttern, DIN 548	273
		Käfigmuttern, N0440	317	Kreuzlochschrauben, DIN 404	72
	3	Kappen	siehe Abdeckkappen	Kronenmuttern, DIN 935	282
		Karoseriescheiben, DIN 9021	376	Kronenmuttern, niedrige Form, DIN 937	284
		Kauschen Form A, DIN 6899	470	Kronenmuttern, niedrige Form, DIN 979	285
		Kegelgriffe Form L + N, DIN 99	461	Kronleuchterhaken, A013	211
	4	Kegelkerbstifte, DIN 1471	404	Kugeldruckstück	siehe Federnde Druckstücke
		Kegelkerbstifte, ISO 8744	404	Kugelknöpfe Form E mit Gewindebuchse, DIN 319	462-463
		Kegelstifte, DIN 1	396-397	Kunststoffe (Thermoplaste)	525
	5	Kegelstifte mit Gewindezapfen, DIN 7977	426-427	Kupfermuttern, DIN 14440, DIN14441	307-308
		Kegelstifte mit Innengewinde, DIN 7978	428-429	L	
		Keilsicherungsscheiben, Nord-Lock, N0115	384-385	LAMA-Flügelköpfe, N0430	484
		Kennzeichen, CE	547	LAMA-Rändelköpfe, N0410	483
	6	Kennzeichnung von HV- und SB-Garnituren	546	L-Anschweißmuttern, N0301	315
		Kennzeichnung von Schrauben und Muttern	536-543	Leichtbauplattenstifte, DIN 1144	400
	7	Kerbstifte / Kerbnägel	403-411	L-Einschlagmuttern, N0300	314
		Kernlöcher für Blechschrauben	578-579	Linsenflanschschrauben mit Innensechskant, ISO 7380F	194-195
		Ketten nach DIN 5685 (G), N0750	485	Linsensenkholzschrauben mit Kreuzschlitz, DIN 7995	188
	8	Klappsplinte mit rundem Federring, N0040	449	Linsensenschrauben mit Kreuzschlitz, DIN 966	150-151
		Klebende Beschichtung, DIN 267	584	Linsensenschrauben mit Schlitz, DIN 964	146-147
		Klemmende Beschichtung DIN EN ISO 2320	590	M	
	9	Klemmscheiben, N0400	390	Mechanische Eigenschaften der austenitischen Stahlgruppe	522
		Knebelkerbstifte mit kurzen Kerben, DIN 1475	409	Mechanische Eigenschaften von Muttern	518-519
		Knebelkerbstifte mit kurzen Kerben, ISO 8742	409	Mechanische Eigenschaften von Schrauben	514-516
		Knöpfe, Form E mit Gewindebuchse, DIN 319	462-463	Mechanische Eigenschaften von Schrauben aus nicht rostendem Stahl	521
		Kontaktkorrosion in Betrachtung der Werkstoffe	557	Messing, Anziehdrehmomente	577
		Kontaktscheiben, NFE25511	393	Muffen mit Innen-/Innengewinde, N0372	507
		Kontaktscheiben, gezahnt, ART55	378	Muffen rund, Innengewinde, N0370	504
		Korrosionsarten, allgemein	556		











Muffen sechskant, Innengewinde, N0371	505-506	RIBE-Käppi, N0070	475
Muttern, sechskant	siehe Sechskantmuttern	Ringmuttern, DIN 582	276-277
Mutterwerkstoffe	520	Ringschrauben, A001	202-203
N		Ringschrauben, A048	214-215
Nasenkeile, DIN 6887	422	Ringschrauben, DIN 580	90-91
Nägel mit Senkkopf, DIN 1151	401	Ringschrauben, stark, A002	204
Nägel mit Stauchkopf, DIN 1152	402	Ripp-Muttern, P193	321
Nichteisenmetalle nach ISO 8839	524	Ripp-Schrauben mit Innensechskant, P251	239
Nieten	454-457	Ripp-Schrauben mit Sechskantkopf, P158	238
Nord-Lock Sicherungsscheiben, N0115	384-385	Rohrklappsplinte, N0041	450
Nutenschrauben, DIN 787	108-109	Rohrmuttern, DIN 431	266
Nutensteine, DIN 508	270	Rohrstopfen	siehe Verschlusschrauben
Nutmuttern, DIN 1804	296-297	Rosetten, N0080	380
Nutmuttern, DIN 70852	309	Rosetten, vollmetall, N0082	381
Nutmuttern für Wälzlager, DIN 981	287-288	RS-Scheiben, DIN 6799	364
Nytemp®	582-590	Rückwandschrauben, N0090	224
P		Runddrahtsprengringe für Bohrungen (Form B), DIN 7993	375
Passfedern		Runddrahtsprengringe für Wellen (Form A), DIN 7993	373-374
Form A, rundstirnig, DIN 6885	414-421	Rundmuttern Typ RF, N0163	502
Passivieren, Dickschicht, DIN 50961	563	Rundmuttern Typ RTL, N0175	503
Passkerbstifte, DIN 1472	405	Rundstahlbügel Form A, DIN 3570	466
Passkerbstifte, ISO 8745	405	S	
Passscheiben, DIN 988	348-349	SB-Garnituren, Anziehdrehmomente	575
Passschrauben		SB-Garnituren, DIN EN 15048	190-191
mit Innensechskant, ISO 7379	192	Schaftschrauben mit Schlitz und Kegelkuppe, DIN 427	74
Passschrauben mit Sechskant und kurzen Gewindepapfen, DIN 610	104-105	Schäkel, DIN 82101	473
Passschrauben mit Sechskant und langen Gewindepapfen, DIN 609	102-103	Scheiben, DIN 125	325
Polyamid PA 6.6, Anziehdrehmomente	577	Scheiben, DIN 126	326
Polyamid PA 6.6, Eigenschaften	526	Scheiben, DIN 134	329
Prüfbescheinigungen	591-592	Scheiben Außendurchmesser = 3 X Gewindedurchmesser, DIN 9021	376
PT-Schrauben	siehe Schrauben für Kunststoff	Scheiben für HV-Verbindungen, DIN EN 14399	320
R		Scheiben für Schrauben mit schweren Spannhülsen, DIN 7349	367
Rändelköpfe, N0410	483	Scheiben für Spannzeuge, DIN 6340	358
Rändelmuttern, hohe Form, DIN 466	268	Scheiben für Stahlkonstruktionen, DIN 7989	372
Rändelmuttern, niedrige Form, DIN 467	269	Scheiben für vorwiegend Holzkonstruktionen, DIN 440	337
Rändelschrauben, hohe Form, DIN 464	78		
Rändelschrauben, niedrige Form, DIN 653	106-107		
Reduziermuffen			
mit Innen-/Innengewinde, N0372	507		
Reibwerte	568-569		



	1	Scheiben großer Außendurchmesser für Holzbau, DIN 1052	350	Schrauben für Kunststoff mit Senkkopf und Innensechsrund, W1423	245
		Scheiben kleiner Außendurchmesser, DIN 433	333	Schrauben für Montageschienen	216-221
	2	Scheiben mit Außennase, DIN 432	332	Schrauben f. Thermoplaste	siehe Schrauben für Kunststoff
		Scheiben mit Lappen, DIN 93	324	Schraubensicherungsscheiben, Polyamid, N0450	391-392
		Scheiben, Vergleichstabelle	532-535	Schraubhaken mit Schlitz, A007	208
	3	Scheiben vierkant für Holzkonstruktionen, DIN 436	336	Schraubhaken, gebogen, A011	209
		Scheiben, vierkant, keilförmig für I-Träger, DIN 435	335	Schraubhaken, gebogen mit ISO-Gewinde, A011E	210
		Scheiben, vierkant, Keilförmig für U-Träger, DIN 434	334	Schraubhaken, gerade, A004	206
	4	Scheiben, Ausführung grob für Bolzen, DIN 1441	352	Schraubhaken, gerade mit ISO-Gewinde, A004E	207
		Scheiben, Ausführung mittel für Bolzen, DIN 1440	351	Schulterpassschrauben mit Innensechskant, ISO 7379	192
	5	Scheibenfedern, DIN 6888	423	Schutzkappen für Innensechskantschrauben, N0070	475
		Schlitzmuttern, Auspuff DIN 14440, DIN 14441	307-308	Schutzkappen, sechskant, N0010	474
	6	Schlitzmuttern, DIN 546	271	Schweißmuttern, sechskant, DIN 929	280
		Schlitzschraubhaken, A007	208	Schweißmuttern, vierkant, DIN 928	279
		Schlossschrauben, DIN 603	94-95	Sechskant-Holzschrauben, DIN 571	88-89
	7	Schlüsselschrauben, DIN 571	88-89	Sechskant-Hutmuttern, hohe Form, DIN 1587	295
		Schlüsselweiten und Antriebe	527-531	Sechskant-Hutmuttern mit Klemmteil, nichtmetallischer Einsatz, DIN 986	291
		Schneidschrauben, Gewinde-Schneidschrauben	siehe	Sechskant-Hutmuttern, niedrige Form, DIN 917	278
	8	Schnellbauschrauben mit Bohrspitze, N0100	227	Sechskant-Kronenmuttern, niedrige Form, DIN 979	285
		Schnellbauschrauben mit Doppelgang-Feingewinde, N0100	225	Sechskantmuttern, DIN 934	281
		Schnellbauschrauben mit Grobgewinde, N0100	226	Sechskantmuttern, ISO 4032	410
	9	Schnorr Sicherungsscheiben, N0110	382-383	Sechskantmuttern 1,5 d hoch, DIN 6330	299
		Schrauben für Kunststoff, Flachkopf mit Flansch und Innensechsrund, W1451	243	Sechskantmuttern 1,5 d hoch mit Bund, DIN 6331	300
		Schrauben für Kunststoff mit Flachkopf (Kreuzschlitz), W1412	241	Sechskantmuttern, 3 d hoch, DIN 6334	301
		Schrauben für Kunststoff mit Flachkopf und Innensechsrund, W1452	244	Sechskantmuttern für HV-Verbindungen, DIN EN 14399	266
		Schrauben für Kunststoff, Flachkopf und Flansch (Kreuzschlitz), W1411	240	Sechskantmuttern mit Flansch, DIN 6923	302
		Schrauben für Kunststoff mit Senkkopf (Kreuzschlitz), W1413	242	Sechskantmuttern mit Flansch und Klemmteil ganzmetall, DIN 6925	304
				Sechskantmuttern mit Flansch und Klemmteil nichtmetallischer Einsatz, DIN 6926	305
				Sechskantmuttern mit Klemmteil Ganzmetallmuttern, DIN 980	286

Sechskantmuttern mit Klemmteil, nichtmetallischer Einsatz, hohe Form, DIN 982	289	Senkschrauben mit Kreuzschlitz, DIN 965	148-149
Sechskantmuttern mit Klemmteil, nichtmetallischer Einsatz, DIN 985	290	Senkschrauben mit Nase, DIN 604	96-97
Sechskantmuttern mit Klemmteil, nichtmetallischer Einsatz, DIN 6924	303	Senkschrauben mit Schlitz, DIN 963	144-145
Sechskantmuttern, niedrige Form, DIN 439	267	Setzmuttern, N0302	316
Sechskantmuttern, niedrige Form, DIN 936	283	Sicherheitsblechschrauben mit Flachrundkopf und TORX-Pin S7381	233
Sechskantschrauben für HV-Verbindungen, DIN EN 14399	186-187	Sicherheitsblechschrauben mit Senkkopf und TORX-Pin, S7982	234
Sechskantschrauben mit 6kt-Mutter für Stahlkonstruktion, DIN 7990	182-185	Sicherheitssschrauben mit Flachrundkopf und TORX-Pin, S7380	232
Sechskantschrauben mit Ansatzspitze, DIN 564	86-87	Sichern von Schraubverbindungen	580-581
Sechskantschrauben mit Flansch, DIN 6921	156	Sichernde Beschichtungen	582-590
Sechskantschrauben mit Gewinde bis Kopf, DIN 933	134-135	Sicherheitssschrauben mit Senkkopf und TORX-Pin	233
Sechskantschrauben mit Gewinde bis Kopf, ISO 4017	189	Sicherungsbleche für Nutmuttern, DIN 5406	356-357
Sechskantschrauben mit Gewinde bis Kopf und metrischem Feingewinde, DIN 961	142-143	Sicherungsbleche, DIN 5406	356-357
Sechskantschrauben mit Schaft, DIN 601	92-93	Sicherungsbleche mit 2 Lappen, DIN 463	339
Sechskantschrauben mit Schaft, DIN 931	132-133	Sicherungsbleche mit Innennase, DIN 462	338
Sechskantschrauben mit Schaft, ISO 4014	189	Sicherungsmuttern, DIN 7967	306
Sechskantschrauben mit Schaft und metrischem Feingewinde, DIN 960	140-141	Sicherungsmuttern siehe Sechskantmuttern mit Klemmteil	
Sechskantschrauben mit Zapfen, DIN 561	85	Sicherungsmuttern mit Flansch, ganzmetall, DIN 6925	304
Sechskant-Schutzkappen, N0010	474	Sicherungsmuttern mit Flansch, nichtmetallischer Einsatz, DIN 6926	305
Sechskant-Schweißmuttern, DIN 929	280	Sicherungsringe für Bohrungen, DIN 472	343-344
Senkkerbnägel, DIN 1477	411	Sicherungsringe für Wellen, DIN 471	341-342
Senkkerbnägel, ISO 8747	411	Sicherungsscheiben für Wellen, DIN 6799	364
Senkkopfdrahtstifte, DIN 1151	401	Sicherungsscheiben, Nord-Lock, N0115	384-385
Senkkopfschrauben mit Innensechskant und TORX-Pin, S7991	235	Sicherungsscheiben, Schnorr, N0110	282-293
Senknieten, DIN 661	455	Spannhülsen leichte Ausführung, DIN 7346	424-425
Senkschrauben mit Innensechskant, ISO 10642	186	Spannscheiben für Schraubenverbindungen, DIN 6796	359
Senkschrauben, DIN 608	100-101	Spannschlösser aus Stahlrohr, DIN 1478	292
Senkschrauben mit hohem Vierkant, DIN 605	98-99	Spannschlösser, geschmiedet (offene Form), DIN 1480	294
Senkschrauben mit Innensechskant, DIN 7991	186-187	Spannschlossmuttern aus Sechskantstahl, DIN 1479	293
Senkschrauben mit Innensechsrund, ISO 14581	201	Spannstifte geschlitzte, schwere Ausführung, ISO 8752	436-437



	1	Spanplattenschrauben mit Linsenkopf und Kreuzschlitz, WN55	246	T	Tellerfedern, DIN 2093	353-355
	2	Spanplattenschrauben mit Rundkopf und Kreuzschlitz, WN56	247		Tellerkopfschrauben, TOPIX	258-260
	3	Spanplattenschrauben mit Senkkopf und Innensechsrund, WN57	250-251		Thermagmuttern (normale SW), DIN 14440	307
	4	Spanplattenschrauben mit Senkkopf und Kreuzschlitz, WN57	248-249		Thermagmuttern (verringerte SW), DIN 14441	308
	5	Spenglerschrauben, N0492	230		T-Nutenschrauben, DIN 787	108-109
	6	Sperrkantringe Form K, N0128	387		T-Nutensteine, DIN 508	270
	7	Sperrkantscheiben Form M, N0125	386		Trapezgewindemuttern, N0934	318-319
	8	Sperrzahn-Muttern, P193	321	U	TufLok®	582-590
	9	Sperrzahn-Schrauben, P151	236-237		Unterlegscheiben, DIN 125	325
		Spiralspannstifte, normale Ausführung, ISO 8750	434-435		Unterlegscheiben, DIN 126	326
		Spiralspannstifte, schwere Ausführung, ISO 8748	432-433		Unterlegscheiben, DIN 134	329
		Splinte, DIN 94	442-443		Unterlegscheiben, DIN 9021	376
		Sprengringe für Bohrungen, DIN 7993	375		Unterlegscheiben, Vergleichstabelle	532-535
		Sprengringe für Wellen, DIN 7993	373-374		Unterlegscheiben	siehe auch Scheiben
		Stahlbauschrauben, DIN 7990	182-185	V	Vergleichstabelle Unterlegscheiben	532-535
		Stahlnägels mit Längsrieffelung, N0250	438		Verlängerungsmuffen mit Sechskant, N0371	505-506
		Starke Ringschrauben, A002	204		Verlängerungsmuttern mit Sechskant, 3 X D hoch, DIN 6334	301
		Stauchkopfdrahtstifte, DIN 1152	402		Verschlusssscheiben, DIN 470	340
		Steckkerbstifte, DIN 1474	408		Verschlusssschrauben mit Bund und Außensechskant, DIN 910	116-117
		Steckkerbstifte, ISO 8741	408		Verschlusssschrauben mit Bund und Innensechskant, DIN 908	114-115
		Stehbolzen	siehe Stiftschrauben		Verschlusssschrauben mit kegeligem Gewinde und Innensechskant, DIN 906	112-113
		Steinschrauben Form C, DIN 529	82		Vierkantscheiben	siehe Scheiben vierkant
		Stellmutter	siehe Kreuzlochmuttern		Vierkantmuttern, DIN 557	274
		Stellringe Form A, DIN 705	345		Vierkantmuttern, niedrige Form, DIN 562	275
		Sterngriffe Form K: mit Gewindebuchse, DIN 6336	468-469		Vierkantscheiben I-Profil, DIN 6917	365
		Stiftschlüssel, DIN 911	465		Vierkantscheiben U-Profil, DIN 6918	366
		Stiftschrauben			Vierkantschrauben mit Bund, DIN 480	80
		Einschraubende ca. 1 X D, DIN 938	136-137		Vierkantschrauben mit Kernansatz, DIN 479	79
		Einschraubende ca. 1,25 X D, DIN 939	138-139		Vierkant-Schweißmuttern, DIN 928	279
		Stiftschrauben		W	Wäscheleinenhaken, A015	212
		Einschraubende ca. 2 X D, DIN 835	110-111		Wellenringe, DIN 471	341-342
		Stockschrauben, N0120	228			
		Sturmhakenösen, A003	205			
		Stützscheiben, DIN 988	346-347			

Werkzeugnisse	592
Winkelschrauben	206-208
Z	
Zahnscheiben Form A / Form I, DIN 6797	360
Zahnscheiben Form V, DIN 6797	361
Zapfenschrauben mit Schlitz, DIN 927	131
Zeugnisse	592
Zinklamellenüberzüge, DIN EN ISO10683	562, 566-567
Zusammensetzung von austenitischen Stählen, chemisch	523
Zweilochmuttern, DIN 547	272
Zylinderkerbstifte mit Einführende, DIN 1470	403
Zylinderkerbstifte mit Einführende, ISO 8739	403
Zylinderkerbstifte mit Fase, DIN 1473	406-407
Zylinderkerbstifte mit Fase, ISO 8740	406-407
Zylinderkopfschrauben mit Schlitz, DIN 84	64-65
Zylinderschrauben mit Innensechskant, DIN 912	118-119
Zylinderschrauben mit Innensechskant niedriger Kopf, DIN 6912	154-155
Zylinderschrauben mit Innensechskant und niedrigem Kopf, DIN 7984	178-179
Zylinderschrauben mit Innensechsrund, ISO 14580	200
Zylinderstifte gehärtet und geschliffen, DIN 6325	412-413
Zylinderstifte mit Innengewinde, DIN 7979	430-431
Zylinderstifte ungehärtet, DIN 7	398-399

1



2



3



4



5



6



7



8



9





1

Anschrift:

Schrauben-Jäger AG
Industriestraße 15
D-76189 Karlsruhe



2

Telefon: +49 (0)721 57006-0**Fax:** +49 (0)721 57006-11

3

E-Mail: verkauf@schrauben-jaeger.de**Vertretungsberechtigter Vorstand:**

Herr Siegmар Weber



4

Registergericht/Handelsregister:

Registergericht Mannheim, HRB 109736

USt-Ident-Nr. DE 811 174 979

5

Dieser Katalog erhebt keinen Anspruch auf Fehlerfreiheit und entbindet daher den Verwender dieser Informationen nicht von der Pflicht zur Prüfung des jeweiligen Einzelfalls. Für die Vollständigkeit und Richtigkeit wird keine Haftung übernommen. Irrtümer und Schreibfehler bleiben vorbehalten.



6

Alle Namen, Logos und Abbildungen unterliegen gewerblichen Schutzrechten der jeweiligen Produkthersteller und Firmen. Nachdruck nur mit schriftlicher Genehmigung der Schrauben-Jäger AG. Weitere rechtliche Hinweise entnehmen Sie bitte unseren AGB.



7

© 2015 by Schrauben-Jäger, Karlsruhe



8

Es gelten die allgemeinen Geschäftsbedingungen der Schrauben-Jäger AG.



9